

# Instruction Manual

## *QDP Drystar<sup>®</sup> Vacuum Pumps*

### *Description*

*QDP40 Drystar Pump*  
*QDP80 Drystar Pump (4 kW)*  
*QDP80 Drystar Pump (8 kW)*

### *Item Number*

*A528-40-905*  
*A528-79-905*  
*A528-80-905*

*Drystar is a registered Trademark of the BOC group of companies*



**Edwards High Vacuum International**  
Manor Royal, Crawley, West Sussex, RH10 2LW, UK  
Telephone: (01293) 528844 Fax: (01293) 533453 Telex: 87123 Edivac G



We, Edwards High Vacuum International,  
Manor Royal,  
Crawley,  
West Sussex RH10 2LW, UK

declare under our sole responsibility that the product(s)

Standard pumping system configured using the Q-matrix modular build structure,  
as shown below

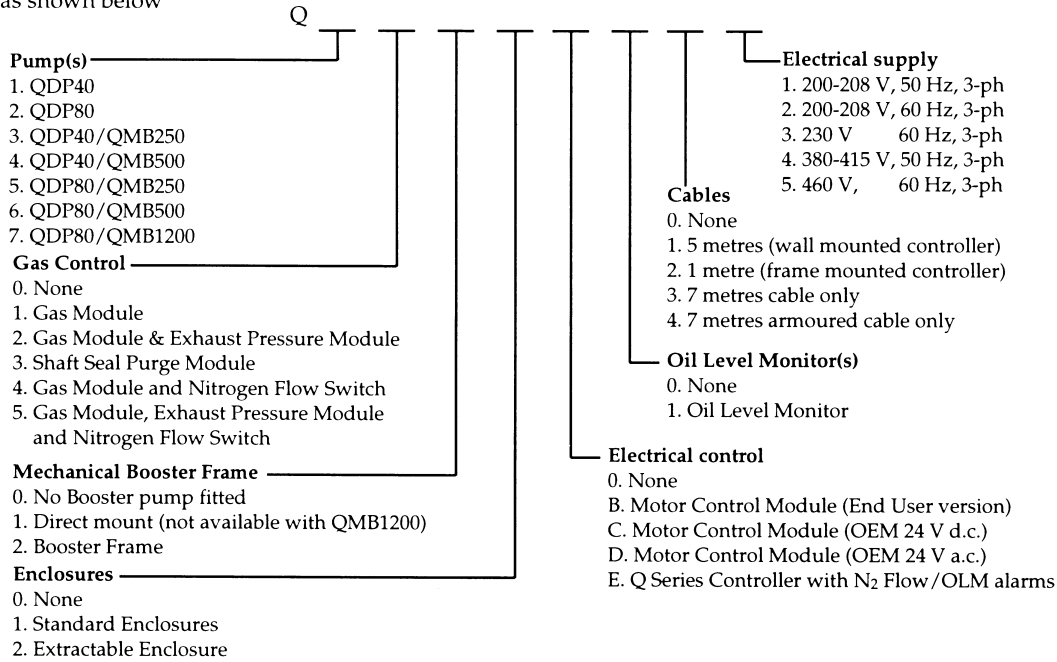

and the following standard accessories, not configured via the Q-matrix:

Water Cooled Exhaust Trap	A531-14-000
Enclosure Extraction Fan Kit	A223-01-006
Dual Enclosure Extraction Fans Kit	A528-60-000

to which this declaration relates is in conformity with the following standard(s)  
or other normative document(s)

EN 60204-1

Electrical Safety: Machines.

following the provisions of

89/392/EEC  
89/336/EEC  
73/023/EEC

Machinery Safety Directive.  
Electromagnetic Compatibility Directive.  
Low Voltage Directive.

  
\_\_\_\_\_  
Dr. A. P. Troup, Director of Technology

  
\_\_\_\_\_  
14/5/16 Crawley  
Date and Place

# CONTENTS

Section	Title	Page
1	INTRODUCTION	1
1.1	Scope and definitions	1
1.2	Description	1
1.2.1	Overview	1
1.2.2	The QDP pump	1
1.2.3	Gas system	2
1.2.4	Temperature control system	3
1.2.5	Electrical system	4
1.2.6	Exhaust system	4
1.3	Accessories	4
2	TECHNICAL DATA	5
2.1	General	5
2.2	Performance data	5
2.3	Services	10
2.4	Full load current ratings	11
2.5	Temperature control system	11
2.6	Electrical connectors	12
2.7	Lubrication system	12
2.7.1	Gearbox	12
2.7.2	High vacuum bearings	12
2.8	Exhaust system	12
2.8.1	Exhaust-silencer	12
2.8.2	Exhaust check-valve	12
3	INSTALLATION	13
3.1	Safety	13
3.2	Unpack and inspect	13
3.3	Height adjustment	14
3.4	Check the coolant-level	14
3.5	Check the gearbox oil-level	14
3.6	Locate the pump	14
3.7	Electrical connections	16
3.7.1	17-way connector	16
3.7.2	High and low voltage operation	19
3.7.3	Connect the electrical supply	19
3.7.4	Connect the thermal snap-switches	20
3.7.5	Connect the motor-protection thermistors	20
3.7.6	Check the pump rotation	23
3.8	Fit a mechanical booster pump	23
3.9	Connect the cooling-water supply	23
3.10	Connect the nitrogen supply	24
3.11	Connect the pump to your vacuum system	24

Section	Title	Page
3.12	Exhaust system connection	25
3.12.1	Use of the alternative outlet position	25
3.12.2	Connect the pump to your exhaust system	26
3.13	Leak-test the installation	27
3.14	Commission the pump	27
3.14.1	Adjust the thermostatic control-valve (TCV)	27
3.14.2	Commissioning procedure	28
4	OPERATION	29
4.1	Start-up procedure	29
4.2	Gas flow rates and pressures	29
4.3	Pump shutdown	29
5	MAINTENANCE	30
5.1	Safety	30
5.2	Maintenance plan	31
5.3	Check the gearbox oil-level	31
5.4	Check the coolant-level	32
5.5	Inspect and clean the exhaust-silencer	33
5.6	Inspect the pipelines and connections	35
5.7	Inspect the exhaust check-valve	35
5.8	Change the gearbox oil	37
5.9	Relubricate the rotor bearings	37
6	STORAGE AND DISPOSAL	39
6.1	Storage	39
6.2	Disposal	39
7	SPARES AND ACCESSORIES	40
7.1	Introduction	40
7.2	Spares	40
7.3	Accessories	41
	RETURN OF EDWARDS EQUIPMENT	

## Illustrations

Figure	Title	Page
1	Schematic diagram of the gas system	2
2	Services panels	3
3	QDP40 Pump dimensions without enclosures (mm)	6
4	QDP80 Pump dimensions without enclosures (mm)	7
5	Typical pumping speeds for QDP40: pumping speed against pressure	8
6	Typical pumping speeds for QDP80: pumping speed against pressure	8
7	QDP40 Power curves	9
8	QDP80 Power curves	9
9	Remove the pump from the pallet	15
10	Cooling system and lubrication system components	17
11	17-way connector wiring	18
12	QDP40 low voltage configuration	21
13	QDP40 high voltage configuration	21
14	QDP80 low voltage configuration	22
15	QDP80 high voltage configuration	22
16	Exhaust-silencer	34
17	Exhaust check-valve	36
18	Rotor bearings relubrication	38

## Tables

Table	Title	Page
1	Maximum cooling-water consumption	10
2	Recommended nitrogen supply pressures and flow rates	10
3	Full load current ratings	11
4	Checklist of components	13
5	17-way connector pins	19
6	Adjust the TCV on the QDP40	28
7	Adjust the TCV on the QDP40	28
8	Maintenance plan	31

## Associated publications

Publication title	Publication Number
Vacuum Pump and Vacuum System Safety	P300-20-000
QMB Mechanical booster Pumps	A301-85-880
Q Controller	A380-00-880
CDP Accessories - Flap Valve	A504-51-880
QDP Acoustic Enclosure	A528-01-880
QDP Gas Module	A528-05-880
Q Series 3 Exhaust Pressure Module	A528-50-880
QDP Shaft-Seals Purge Module	A528-55-880
Leak-testing CDP installations	P500-10-000

# 1 INTRODUCTION

## 1.1 Scope and definitions

This manual provides installation, operation and maintenance instructions for the Edwards QDP Drystar Vacuum Pumps, abbreviated to QDP pumps in the remainder of this manual. You must use the pumps as specified in this manual.

Read this manual before you install and operate the pump. Important safety information is highlighted as WARNING and CAUTION instructions; you must obey these instructions. The use of WARNINGS and CAUTIONS is defined below.

### WARNING

Warnings are given where failure to observe the instruction could result in injury or death to people.

### CAUTION

Cautions are given where failure to observe the instruction could result in damage to the equipment, associated equipment or process.

## 1.2 Description

### 1.2.1 Overview

The QDP pumps operate at pressures between atmospheric and ultimate vacuum with no lubricating or sealing fluid in the pumping chamber. This ensures a clean pumping system without back-migration of oil into the system being evacuated.

QDP pumps have enclosed, water-cooled motors and are therefore suitable for applications in clean environments where fan cooling is unacceptable.

The QDP pumps are each fitted with a gas system, exhaust-silencer and check-valve. The pump is fixed to the framework by vibration isolators. The framework has castors and levelling feet.

### 1.2.2 The QDP pump

The QDP pumps are four-stage, positive displacement rotary pumps in which pairs of intermeshing rotors (of different profiles mounted on common shafts) are held in correct phase relation by a pair of timing-gears. The timing-gears and the adjacent double-row angular contact ball-bearings, are oil lubricated.

The pump shafts and rotors are made from cast-iron. The internal and external shaft-seals on the motor drive-shaft are made of polytetrafluoroethylene (PTFE). Bearings are located on the high vacuum end of the shaft, near to the pump-inlet. These bearings are packed with perfluoropolyether (PFPE) grease.

### 1.2.3 Gas system

QDP pumps have a gas system of stainless steel pipelines (see Figure 1) which allows nitrogen to be delivered to the following points :

- Inlet-purge
- Shaft-seal purge
- 2/3-interstage purge
- Exhaust-purge
- 3/4-interstage purge.

You will connect your nitrogen supplies to this gas system through connectors on the gas services panel (see Figure 2).

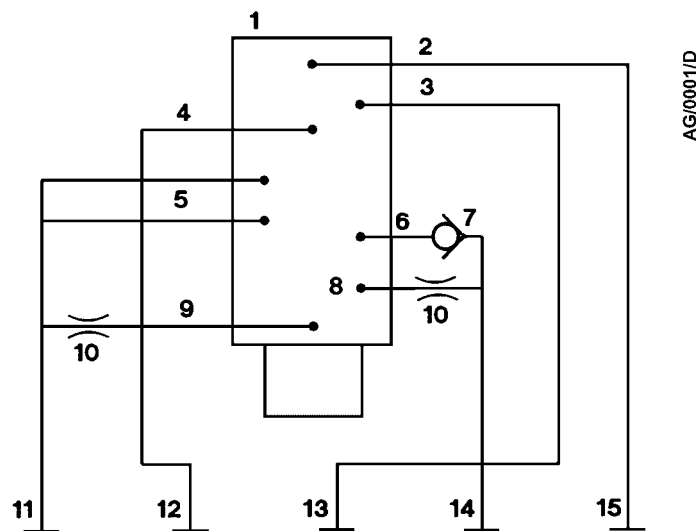

- |                                    |  |
|------------------------------------|--|
| 1. QDP pump                        | 8. Gearbox vent                          |
| 2. Inlet-purge pipeline            | 9. Motor shaft-seals purge pipeline      |
| 3. 2/3-interstage purge pipeline   | 10. Restrictor                           |
| 4. 3/4-interstage purge pipeline   | 11. Shaft-seals purge inlet connector    |
| 5. Pump shaft-seals purge pipeline | 12. 3/4-interstage purge inlet connector |
| 6. Exhaust-purge pipeline          | 13. 2/3-interstage purge inlet connector |
| 7. Check-valve                     | 14. Exhaust-purge inlet connector        |
|                                    | 15. Inlet-purge inlet connector          |

Figure 1 - Schematic diagram of the gas system



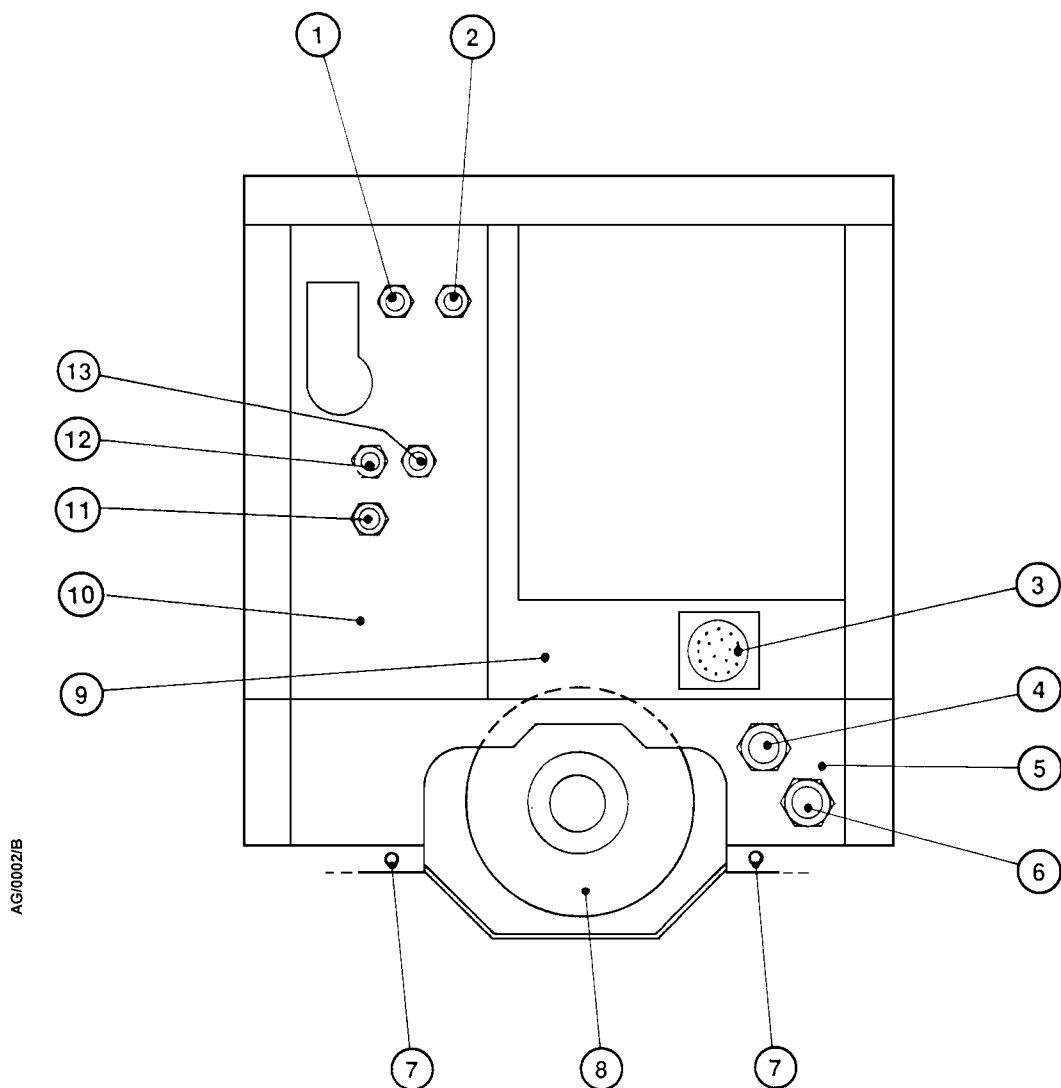

AG/0002/B

- |  |  |
|--|--|
| 1. Exhaust-purge inlet connector         | 8. Exhaust silencer                      |
| 2. Inlet-purge inlet connector           | 9. Electrical services panel             |
| 3. 17-way electrical connector           | 10. Gas services panel                   |
| 4. Water return connector                | 11. 3/4-interstage purge inlet connector |
| 5. Water services panel                  | 12. Shaft-seals purge inlet connector    |
| 6. Water supply connector                | 13. 2/3-interstage purge inlet connector |
| 7. Exhaust support-plate retaining screw |  |

Figure 2 - Services panels

### 1.2.4 Temperature control system

The low vacuum stage of the pump has an indirect cooling system, all other stages are air-cooled by natural convection and radiation. In the secondary circuit of the indirect cooling system, coolant circulates around the pump-body by natural convection. In the primary circuit, cooling-water is circulated through copper coils to extract heat from the coolant. In operation, the pump is maintained at a constant temperature by a thermostatic control-valve (TCV) which controls the supply of cooling-water to the primary circuit in the pump.

The pump-motor is cooled by water flowing through a cooling jacket which surrounds the motor. The pump-motor cooling circuit is separate from the pump cooling circuit. The cooling-water supply and return pipelines are connected to the pump by connectors on the water services panel at one end of the pump (see Figure 2).

The cooling-water manifold on the pump distributes the cooling-water to the pump cooling circuit and to the pump-motor cooling circuit (and to the QMB pump-motor cooling circuit, if a QMB pump is fitted). When a QMB pump is not fitted, the flow of cooling-water to the QDP pump-motor is greater than the minimum required flow. When a QMB pump is fitted, the cooling-water flow is distributed equally between the two pump-motors and the overall flow requirement for the pumping combination increases (see Section 2.3).

Two thermal snap-switches are fitted to the pump-body. One of these snap-switches (the warning switch) opens at 88 °C and the other snap-switch (the shut-down switch) opens at 95 °C. Use the warning switch to provide a warning that the pump is too hot. Use the shut-down switch to shut down the pump.

Three motor-protection thermistors are fitted to the pump-motor (one on each winding). These thermistors are solid-state devices which have an electrical resistance of 100 to 500 Ω at normal pump-motor operational temperature. When the pump-motor is too hot, the electrical resistance rises quickly to 3000 Ω. The thermistors are connected in series and you can use the output of the thermistors to shut down the pump because the motor is too hot.

### **1.2.5 Electrical system**

The QDP pumps have universal voltage and frequency motors. These motors are supplied configured for 'low voltage' operation (200-208 V at 50 Hz or 200-230 V at 60 Hz). To change the motor to 'high voltage' operation, refer to Section 3.8.2.

You will connect your electrical supply cable to the pump through a cable-gland on the terminal-box on the end of the pump-motor (see Figure 10). You must use a suitably rated contactor (see Section 2.4). The electrical services panel has a connector to connect the outputs of the thermal snap-switches and the motor-protection thermistors to your control equipment.

### **1.2.6 Exhaust system**

The pump outlet is connected to an exhaust-silencer, which is below the pump. The outlet also has a port which allows gearbox vent gases to join the main exhaust stream (see Figure 1). The exhaust-silencer attenuates the pulses in the exhaust pressure and reduces pump-induced resonance in your exhaust-extraction system. The outlet of the silencer has a check-valve which prevents the suck-back of exhaust vapours after the pump is shut down. The valve also provides additional attenuation of the pulses in the exhaust pressure.

## **1.3 Accessories**

A number of accessories are available for the QDP pump; use these to configure the pumps for specific applications. These accessories are listed in Section 7.

## 2 TECHNICAL DATA

### 2.1 General

	<b>QDP40</b>	<b>QDP80 (4 kW and 6 kW)</b>
Overall dimensions	See Figure 3	See Figure 4
Mass	172 kg	202 kg
Motor rating	2.2 kW	4 kW/6 kW
Warm-up time to nominal performance	15 min	15 min
Inlet connections	ISO40	ISO63
Outlet connections	NW40	NW40
Vacuum system maximum leak-rate	$1 \times 10^{-5} \text{ mbar.l.s}^{-1}$ ( $1 \times 10^{-3} \text{ Pa.l.s}^{-1}$ )	$1 \times 10^{-5} \text{ mbar.l.s}^{-1}$ ( $1 \times 10^{-3} \text{ Pa.l.s}^{-1}$ )
Exhaust system maximum leak-rate	$1 \times 10^{-5} \text{ mbar.l.s}^{-1}$ ( $1 \times 10^{-3} \text{ Pa.l.s}^{-1}$ )	$1 \times 10^{-5} \text{ mbar.l.s}^{-1}$ ( $1 \times 10^{-3} \text{ Pa.l.s}^{-1}$ )
Ambient operating temperature range	5 to 40 °C	5 to 40 °C
Maximum ambient operating humidity	90% RH	90% RH
Protection degree (as defined by IEC 529)	IP44	IP44
Continuous A-weighted sound pressure level (at 1 meter)	< 70 dB(A)	< 70 dB(A)

### 2.2 Performance data

Pumping speed range	See Figure 5	See Figure 6
Power curves	See Figure 7	See Figure 8
Typical peak pumping speed		
50 Hz	44 m <sup>3</sup> h <sup>-1</sup>	80 m <sup>3</sup> h <sup>-1</sup>
60 Hz	55 m <sup>3</sup> h <sup>-1</sup>	96 m <sup>3</sup> h <sup>-1</sup>
Displacement (swept volume)		
50 Hz	52 m <sup>3</sup> h <sup>-1</sup>	91.5 m <sup>3</sup> h <sup>-1</sup>
60 Hz	62.4 m <sup>3</sup> h <sup>-1</sup>	109.8 m <sup>3</sup> h <sup>-1</sup>
Typical ultimate vacuum without gas-ballast		
50 Hz	$5 \times 10^{-2} \text{ mbar}$ ( $5 \times 10^0 \text{ Pa}$ )	$3 \times 10^{-2} \text{ mbar}$ ( $3 \times 10^0 \text{ Pa}$ )
60 Hz	$3 \times 10^{-2} \text{ mbar}$ ( $3 \times 10^0 \text{ Pa}$ )	$3 \times 10^{-2} \text{ mbar}$ ( $3 \times 10^0 \text{ Pa}$ )

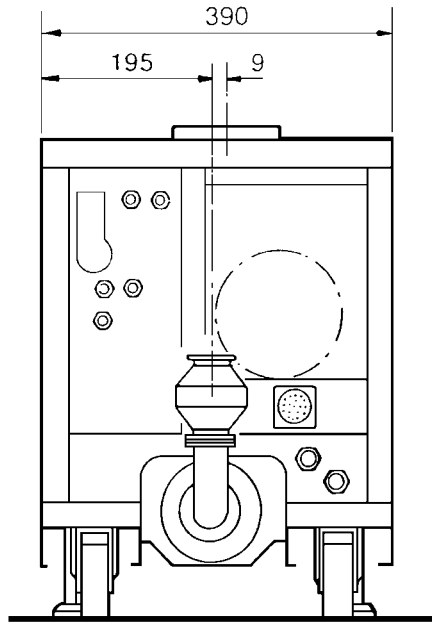

AG0003/F

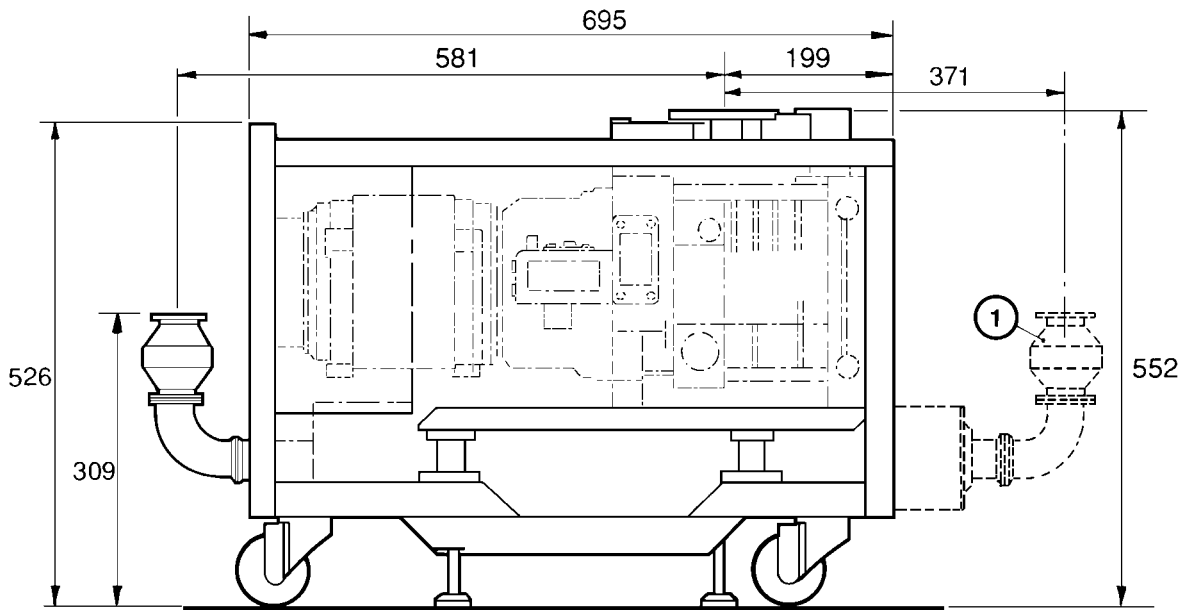

1. Alternative outlet position

Figure 3 - QDP40 Pump dimensions without enclosures (mm)

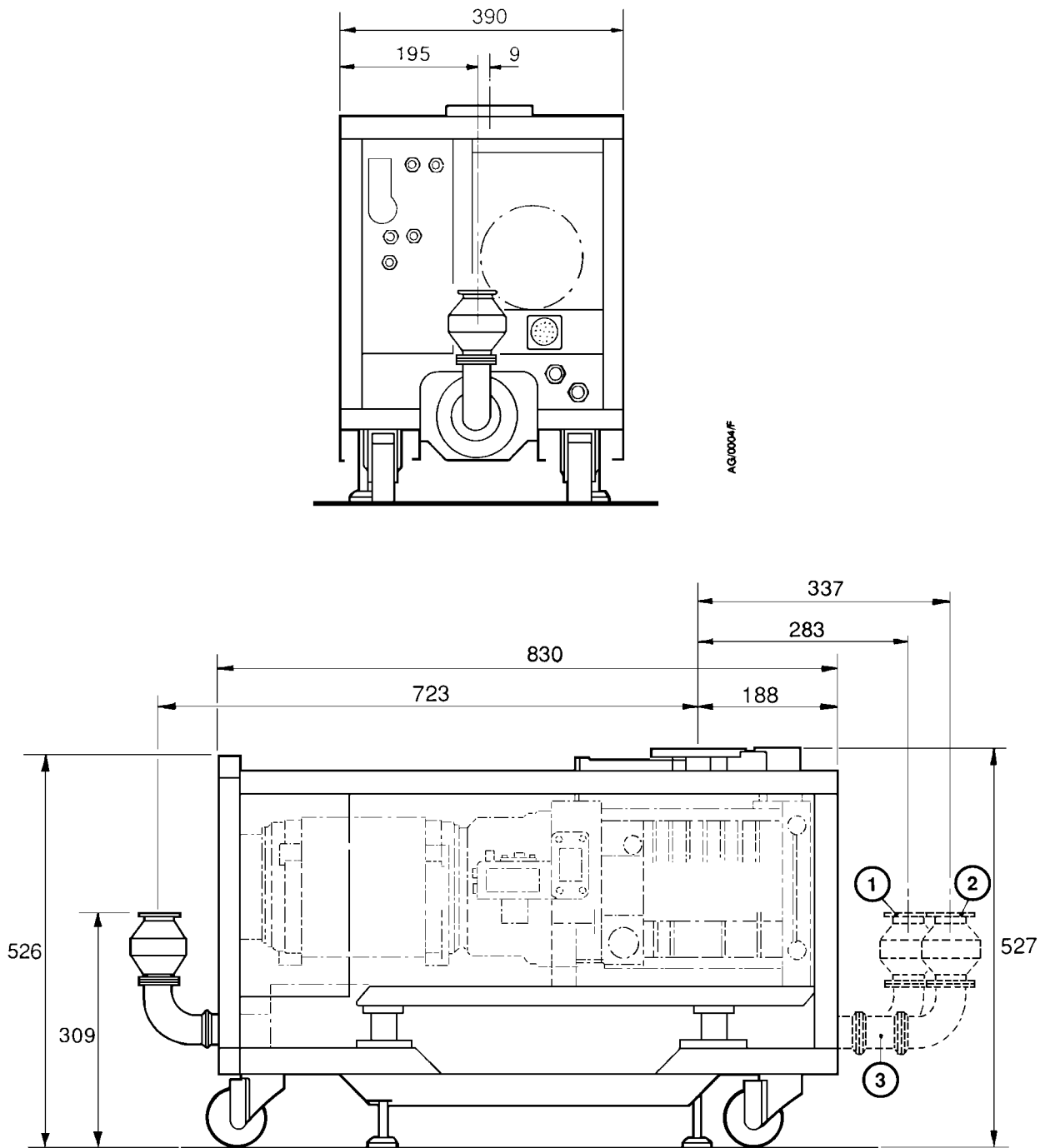

1. Alternative outlet position (without adaptor fitted)
2. Alternative outlet position (with adaptor fitted)
3. Adaptor

Figure 4 - QDP80 Pump dimensions without enclosures (mm)

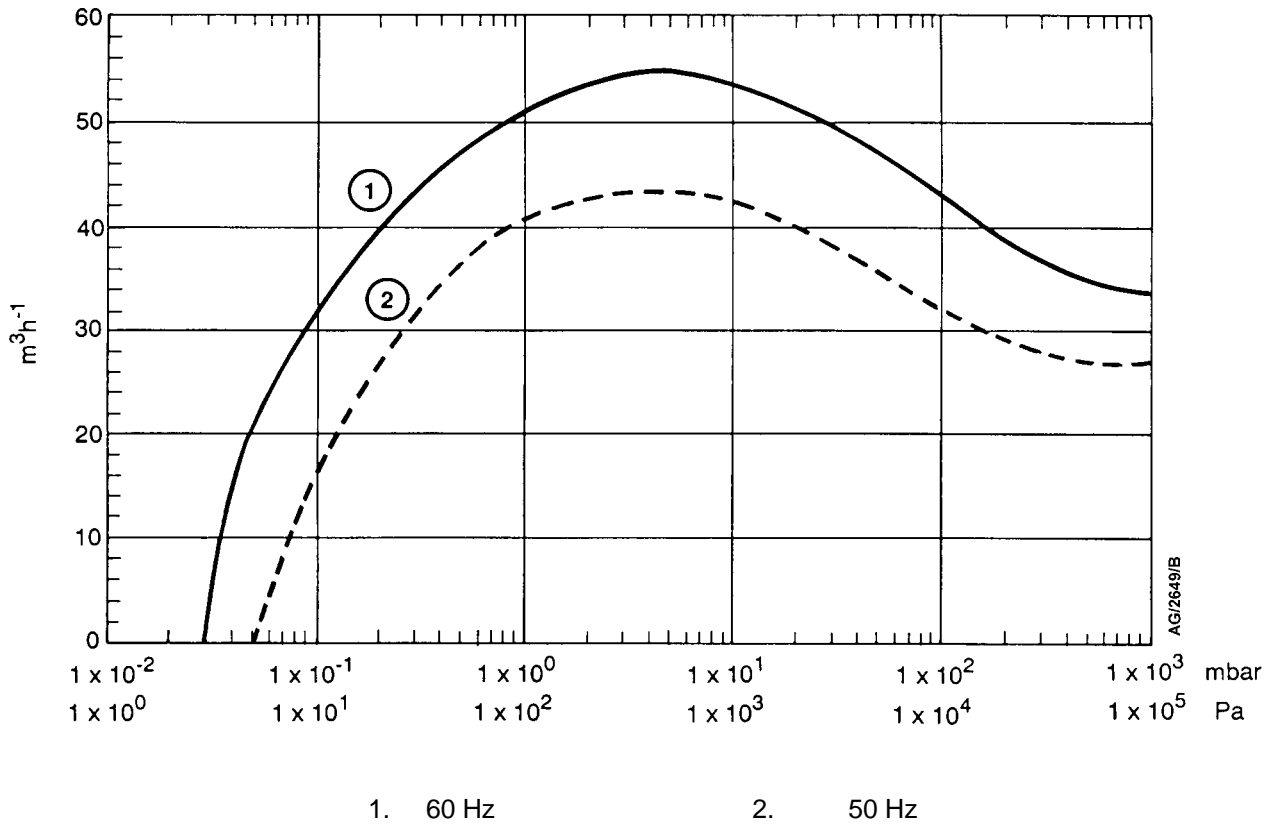

Figure 5 - Typical pumping speeds for QDP40: pumping speed against pressure

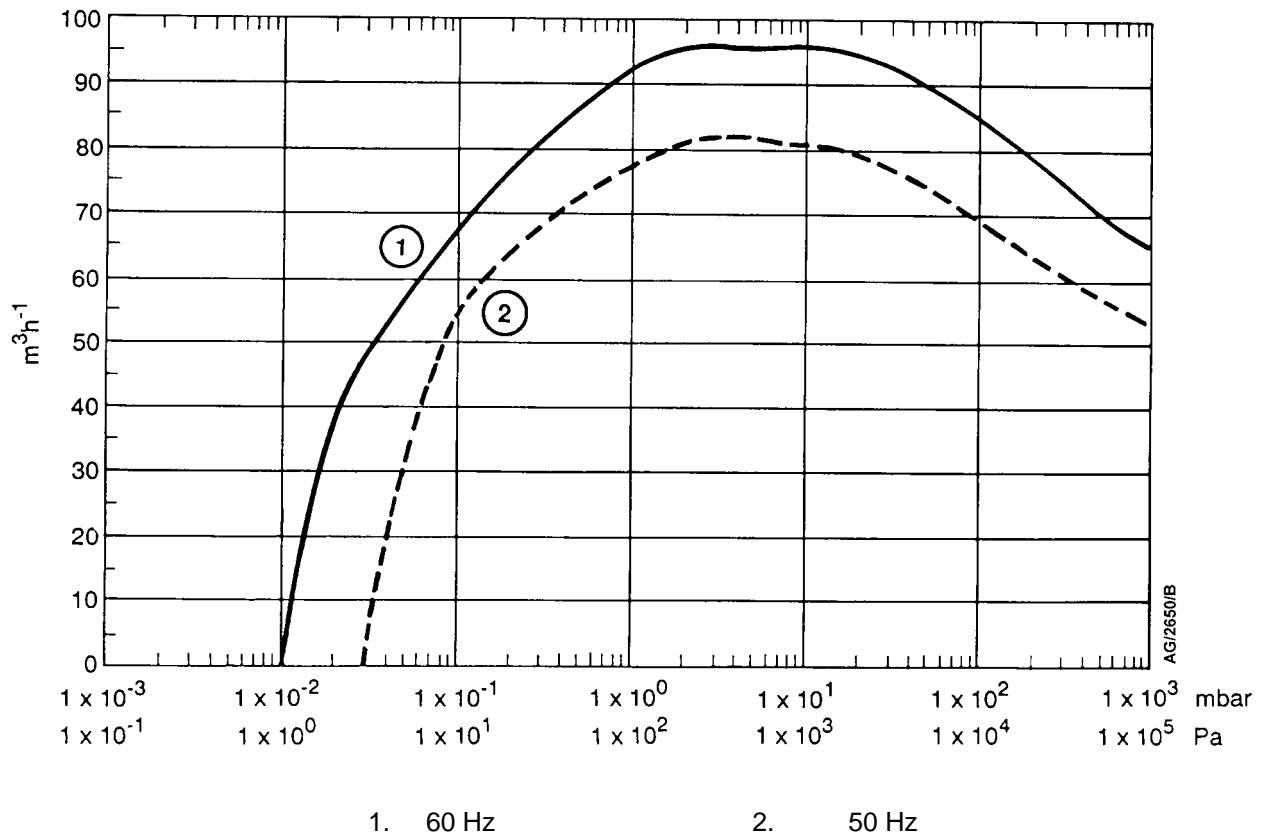
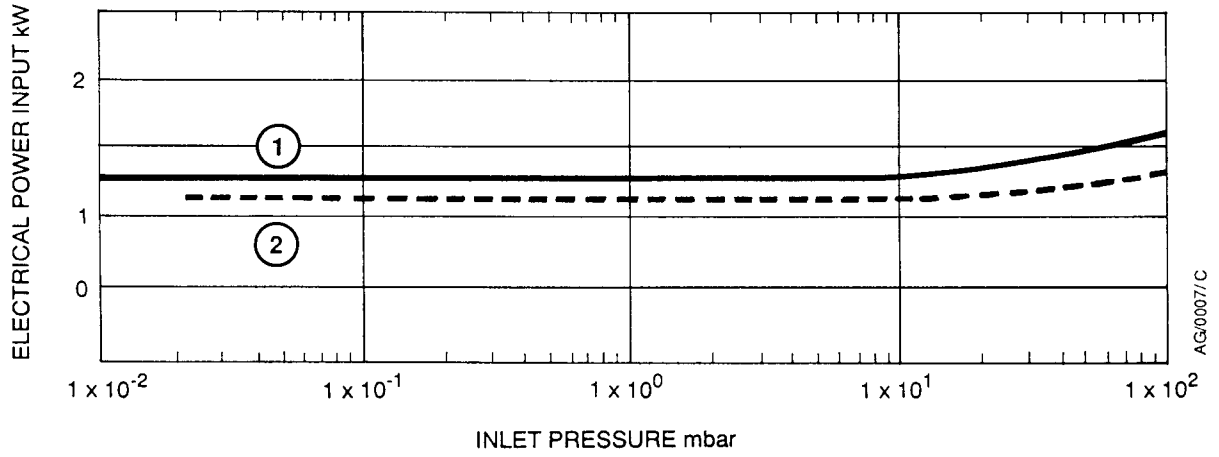
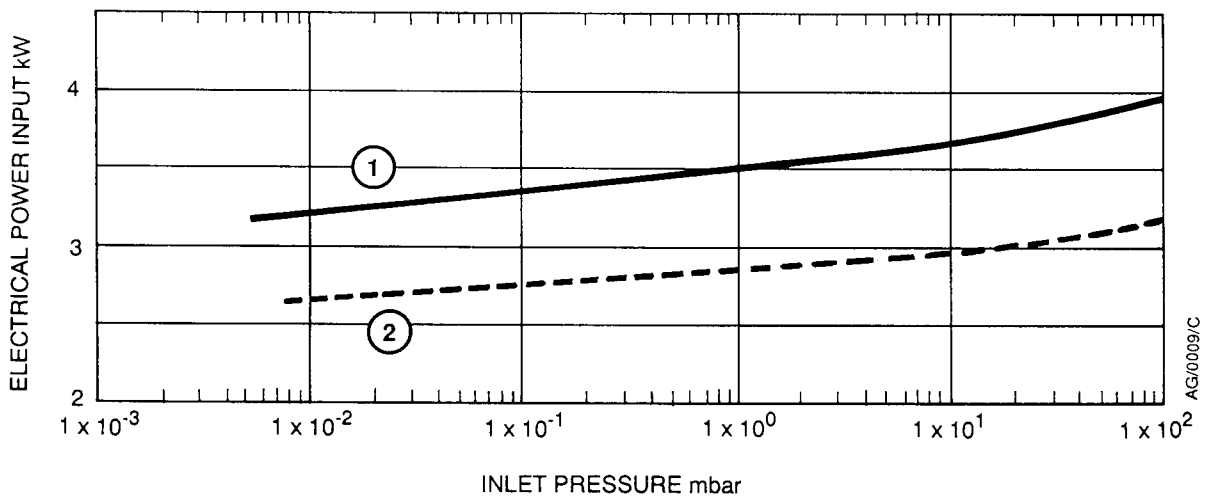

Figure 6 - Typical pumping speeds for QDP80: pumping speed against pressure



1. 60 Hz power curve      2. 50 Hz power curve

Figure 7 - QDP40 Power curves



1. 60 Hz power curve      2. 50 Hz power curve

Figure 8 - QDP80 Power curves

## 2.3 Services

*Note: The motors are supplied configured for low voltage operation (200-208 V at 50 Hz or 200-230 V at 60 Hz). To change the motor to high voltage operation (380-415 V at 50 Hz or 460 V at 60 Hz), refer to Section 3.8.2.*

### Electrical supply

Supply voltage	200-208/380-415 V at 50 Hz, 3-phase 200-230/460 V at 60 Hz, 3-phase
Voltage tolerance	±10% (except for 208 V and 415 V at 50 Hz which are +6% and -10%)

### Cooling-water

Maximum supply pressure	100 psi (6.9 bar absolute, $6.9 \times 10^5$ Pa)
Minimum required pressure differential across supply and return	30 psi ( $2.1 \times 10^5$ Pa)
Typical heat removed from pump	1.75 kW (QDP40), 2.75 kW (QDP80)
Maximum water consumption	See Table 1
Maximum particle size in supply	0.03 mm <sup>2</sup>

### Nitrogen supply

Supply pressures and flow rates	For recommendations, see Table 2
Fittings type	<sup>1</sup> / <sub>4</sub> inch compression

Pump operating temperature (measured at the thermal snap-switch position)	Maximum water consumption at ultimate vacuum with 50 Hz electrical supply, cooling-water supply temperature of 20 °C and a pressure differential across the supply and return of 30 psi ( $2.1 \times 10^5$ Pa)	
	QDP40	QDP80
55 °C	300 lh <sup>-1</sup>	324 lh <sup>-1</sup>
70 °C	150 lh <sup>-1</sup>	165 lh <sup>-1</sup>
90 °C *	135 lh <sup>-1</sup>	126 lh <sup>-1</sup>

\* The 88° thermal snap-switch must be configured to provide warning only, or you must fit the high temperature thermal snap-switch kit: see Section 3.14.1.

Table 1 - Maximum cooling-water consumption

	Shaft-seals purge	3/4-inter-stage purge	2/3-inter-stage purge	Inlet-purge	Exhaust-purge	
Supply pressure (min)	8 psig ( $1.55 \times 10^5$ Pa)	-	-	-	-	
Supply pressure (max)	10 psig ( $1.69 \times 10^5$ Pa)	-	-	-	-	
Flow rate (l.min <sup>-1</sup> )	QDP40 QDP80	25 (max) 25 (max)	20 (max) 25 (max)	5 (max) 10 (max)	25 (max) 25 (max)	5 (typical) 5 (typical)

Table 2 - Recommended nitrogen supply pressures and flow rates



## 2.4 Full load current ratings

Supply voltage and frequency		200-208 V	200-208 V	230 V	380-415 V	460 V
		50 Hz	60 Hz	60 Hz	50 Hz	60 Hz
QDP40 Pump	Full load (A)	8.7	8.8	7.8	5.0	4.4
	Rating (kW)	2.2	2.2	2.2	2.2	2.2
QDP80 Pump (4 kW)	Full load (A)	16.0	16.0	14.2	8.0	8.0
	Rating (kW)	4.0	4.0	4.0	4.0	4.0
QDP80 Pump (6 kW)	Full load (A)	18.9	22.2	19.7	9.5	9.9
	Rating (kW)	5.0	6.0	6.0	5.0	6.0

Table 3 - Full load current ratings

## 2.5 Temperature control system

*Note: An Edwards Health and Safety Data sheet for the coolant used in the QDP pump is available on request.*

### Water-cooling system

Type Indirect water-to-coolant heat exchanger  
Coolant capacity 1.7 litres

### Thermostatic control-valve

Manufacturer Danfoss  
Model AVTA DN15  
Part number 003N2110  
Working temperature range 50 to 90 °C  
Maximum sensor temperature 130 °C

### Thermal snap-switches

Manufacturer Fenwal Inc  
Model 08-02  
Opening temperatures 88 °C (warning switch)  
95 °C (shut-down switch)  
Closing temperatures 78 °C (warning switch)  
85 °C (shut-down switch)

### Contact rating

Maximum voltage 240 V  
Maximum current (inductive load) 6.3 A  
Maximum current (resistive load) 12 A

### Motor-protection thermistors

Type Positive temperature coefficient  
Reference temperature 160 °C  
Compliant with IEC 34-11 (BS4999 part 111)  
Recommended control-unit To comply with IEC 34-11 (BS4999 part 111)  
Relay contact rating Suitable for use with your contactor

## 2.6 Electrical connectors

17-way connector

Pump half

MS type, CA3100E20-29P/F80

Cable half

MS type, CA3106E20-29S

## 2.7 Lubrication system

*Note: Edwards Health and Safety Data sheets for the oils and greases referenced below are available on request.*

### 2.7.1 Gearbox

Oil capacity

0.4 litres

Grade of oil

SAE 40

ISO viscosity grade

150

Recommended perfluoropolyether oils

Fomblin Y25, Krytox 1525

### 2.7.2 High vacuum bearings

Grease type

Perfluoropolyether

Recommended grease

Fomblin RT15

## 2.8 Exhaust system

### 2.8.1 Exhaust-silencer

Gas temperature

5 to 150 °C

Exhaust pulsation attenuation

30 dB(A)

Mass

5.5 kg

### 2.8.2 Exhaust check-valve

Gas temperature

5 to 130 °C

Reverse flow leak tightness when clean  
(minimum)

0.4 mbar.l.s<sup>-1</sup> (4 x 10<sup>1</sup> Pa.l.s<sup>-1</sup>)

Mass

0.95 kg

## 3 INSTALLATION

### 3.1 Safety

**WARNING**

Obey the safety instructions given below and take note of appropriate precautions. If you do not, you can cause injury to people and damage to equipment

- A suitably trained and supervised technician must install the QDP pump.
- Ensure that the installation technician is familiar with the safety procedures which relate to the products pumped. Wear the appropriate safety-clothing when you come into contact with contaminated components. Dismantle and clean contaminated components inside a fume-cupboard.
- Vent and purge the process system (if the QDP Pump is replace an existing pump) with nitrogen for 15 minutes before you start installation work.
- Disconnect the other components in the pumping system from the electrical supply so that they cannot be operated accidentally.
- Do not reuse 'O' rings and do not allow debris to get into the QDP pump during installation.

### 3.2 Unpack and inspect

**WARNING**

Ensure that the maximum angle between paired slings used to lift the pump is 60°.

1. Place the pallet in a convenient position with a fork-lift truck or a pallet truck.
2. Remove the staples which secure the cardboard box to the pallet then remove the cardboard box; alternatively, open the top of the cardboard box. Tear open the foil bag around the pump.
3. Refer to Figure 9. Remove the two nuts and washers (2) which secure the front of the pump to the pallet. Dispose of the nuts and washers. Remove the two nuts and washers (2) which secure the rear of the pump to the pallet.
4. Use suitable lifting-equipment to remove the pump from its pallet. Do not try to lift the pump by hand (see Section 2 for the mass of the pump).
5. Inspect the pump. If the pump or any other item is damaged, notify your supplier and the carrier in writing within three days; state the Item Number of the pump together with your order number and your supplier's invoice number. Retain all packing materials for inspection. Do not use the pump if it is damaged.

6. Check that the pallet contains the items listed in Table 4. If any of these items is missing, notify your supplier in writing within three days.
7. If the pump is not to be used immediately, replace the packing materials. Store the pump in suitable conditions as described in Section 6.

Qty	Description	Check (✓)
1	QDP Pump	<input type="checkbox"/>
1	General fitting-kit	<input type="checkbox"/>

Table 4 - Checklist of components

### 3.3 Height adjustment

The height of the pump-inlet from the ground can be lowered by 6 mm. To lower the pump-inlet, remove each of the castors and then remove the spacer plate between each castor and the pump frame. Refit the castors with 16 mm long M8 cap-head bolts.

### 3.4 Check the coolant-level

Refer to Figure 10.

1. Unscrew and remove the combined filler-plug/level indicator (5). Use a clean lint-free cloth to wipe the shaft of the indicator, then replace the combined filler-plug/level indicator in the coolant header-tank.
2. Remove the combined filler-plug/level indicator again and check the coolant-level: the coolant-level must be visible on the shaft of the indicator, but must not be above the notch mark on the indicator shaft.
3. If necessary, add more coolant: refer to Section 5.4.
4. Check that the bonded seal on the combined filler-plug/level indicator (5) is in place. Refit and tighten the combined filler-plug/level indicator.

### 3.5 Check the gearbox oil-level

Check that the gearbox oil-level is correct; the oil-level must be between the MIN and MAX marks on the bezel of the oil-level sight-glass (see Figure 10). If necessary, drain excess oil from the pump or fill the pump with oil: refer to Section 5.3.

### 3.6 Locate the pump

1. Refer to Figure 9. Remove the nuts and washers (8) fitted to the top of the four levelling feet (7), then retract the levelling feet.
2. Wheel the pump on its castors to move the pump into its operating position. The QDP pump must be located on a firm, level surface.
3. Once located in its final operating position, adjust the levelling feet to make sure that the QDP pump is level and is not supported by the castors.

AW11972/A

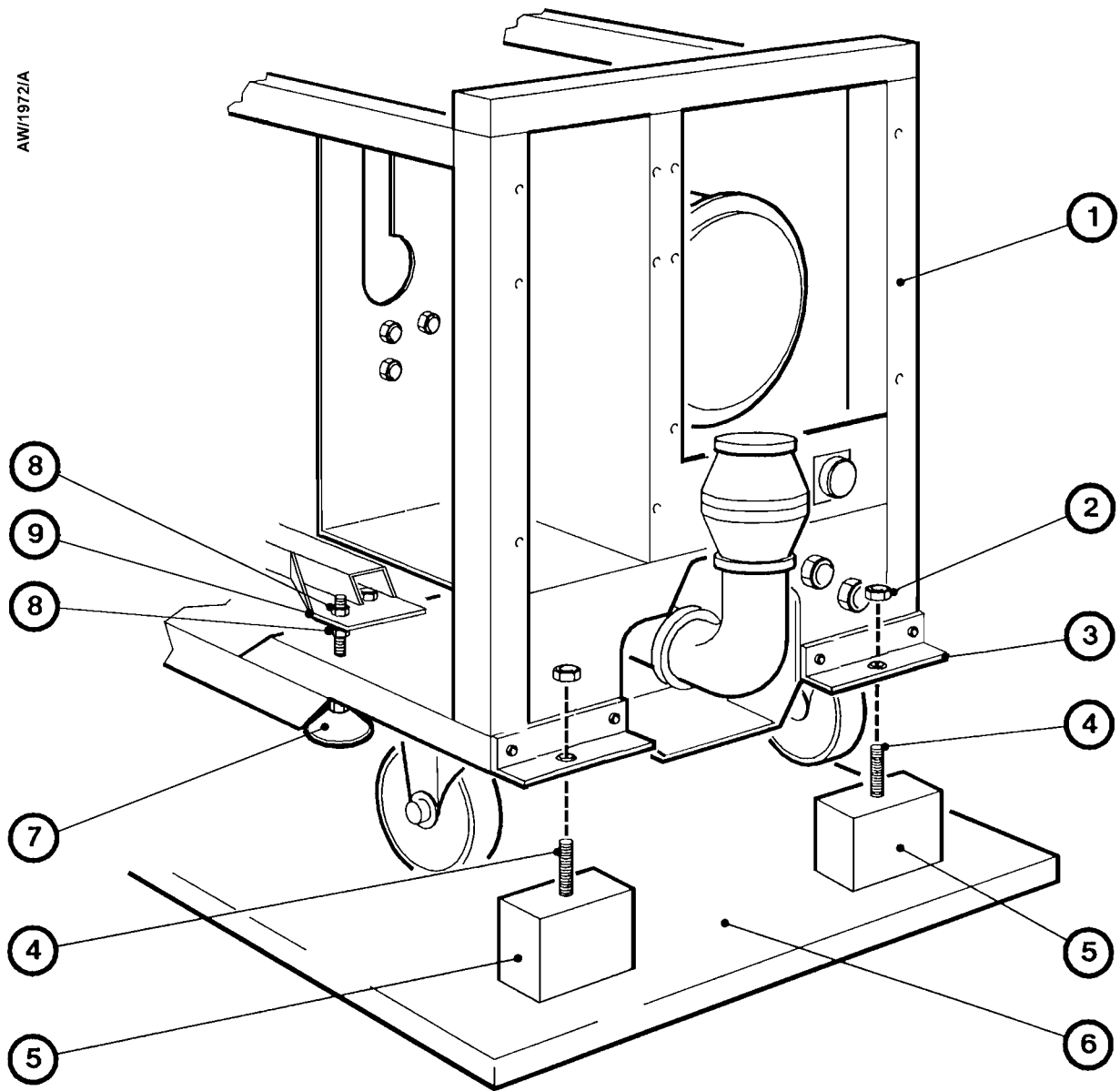

- |                   |                   |
|-------------------|-------------------|
| 1. QDP pump frame | 6. Pallet         |
| 2. Nut and washer | 7. Levelling foot |
| 3. Bracket        | 8. Nut and washer |
| 4. Stud           | 9. Bracket        |
| 5. Block          |                   |

Figure 9 - Remove the pump from the pallet

## 3.7 Electrical connections

### WARNING

If you use gas dilution as a safety feature of your system, you must fit a suitable alarm and interlock system to prevent operation of the QDP pump when the gas dilution system does not work. If you do not, the concentration of dangerous process gases in the exhaust of the pump may (without warning) exceed safe limits and may cause an explosion or injury to people.

### WARNING

Use a suitable cable-gland so that the seal of the electrical cable entry into the motor terminal-box meets the requirements of IP44 in IEC 529. If you do not, condensation may form inside the terminal-box and there may be a risk of electric shock.

### WARNING

Do not turn on the cooling-water supply until after you complete the electrical installation of the pump. If you do, condensation may form inside the motor terminal-box and there may be a risk of electric shock.

### 3.7.1 17-way connector

There is a 17-way connector (Figure 2, item 3) on the electrical services panel for the outputs from the thermal snap-switches and the motor-protection thermistors. The connector may also be used to carry electrical supplies and signals to pump accessories (refer to the instruction manual supplied with your accessory). A wiring diagram for the connector is shown in Figure 11; all of the wiring shown in this figure is inside the QDP frame.

Note also that:

- A mating-half for the 17-way connector is not supplied with the pump: refer to Section 7.3 for the Item Number of the connector mating-half.
- A 3-way mating-half for the flow-switch link (3) is supplied fitted to the connector on the flying leads in the pump. You must remove this link if you fit a flow-switch.
- A 2-way mating-half for the QMB thermistors electrical connector (4) is supplied fitted to the connector on the flying leads in the pump. If you fit a QMB mechanical booster pump, you must remove the link from the mating-half and connect the QMB thermistors through the mating-half of this 2-way connector.

We recommend that you use the pins of the 17-way connector as shown in Table 5.

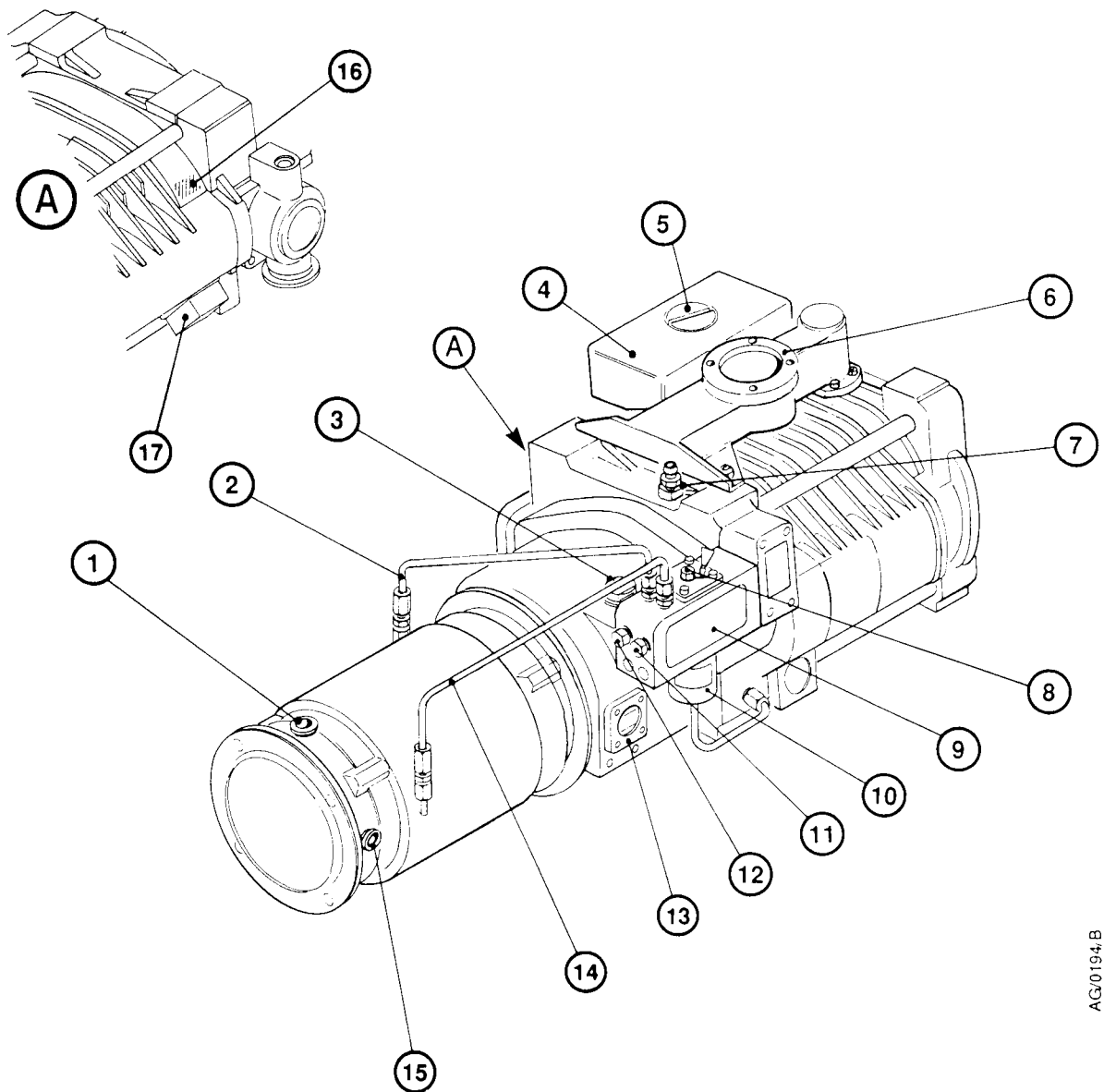

AG/0194,B

- |   |  |
|---|--|
| 1. Electrical supply cable-gland            | 9. Cooling-water manifold                  |
| 2. Pump-motor cooling-water pipe            | 10. Thermostatic control-valve (TCV)       |
| 3. Oil filler-plug                          | 11. Cap (over QMB water return connection) |
| 4. Coolant header-tank                      | 12. Cap (over QMB water supply connection) |
| 5. Combiner filler-plug/<br>level indicator | 13. Oil-level sight-glass                  |
| 6. Inlet                                    | 14. Pump-motor cooling-water pipe          |
| 7. Air bleed-valve                          | 15. Thermistors cable-gland                |
| 8. TCV adjuster spindle                     | 16. Temperature measurement point          |
|   | 17. Thermal snap-switch box                |

Figure 10 - Cooling system and lubrication system components

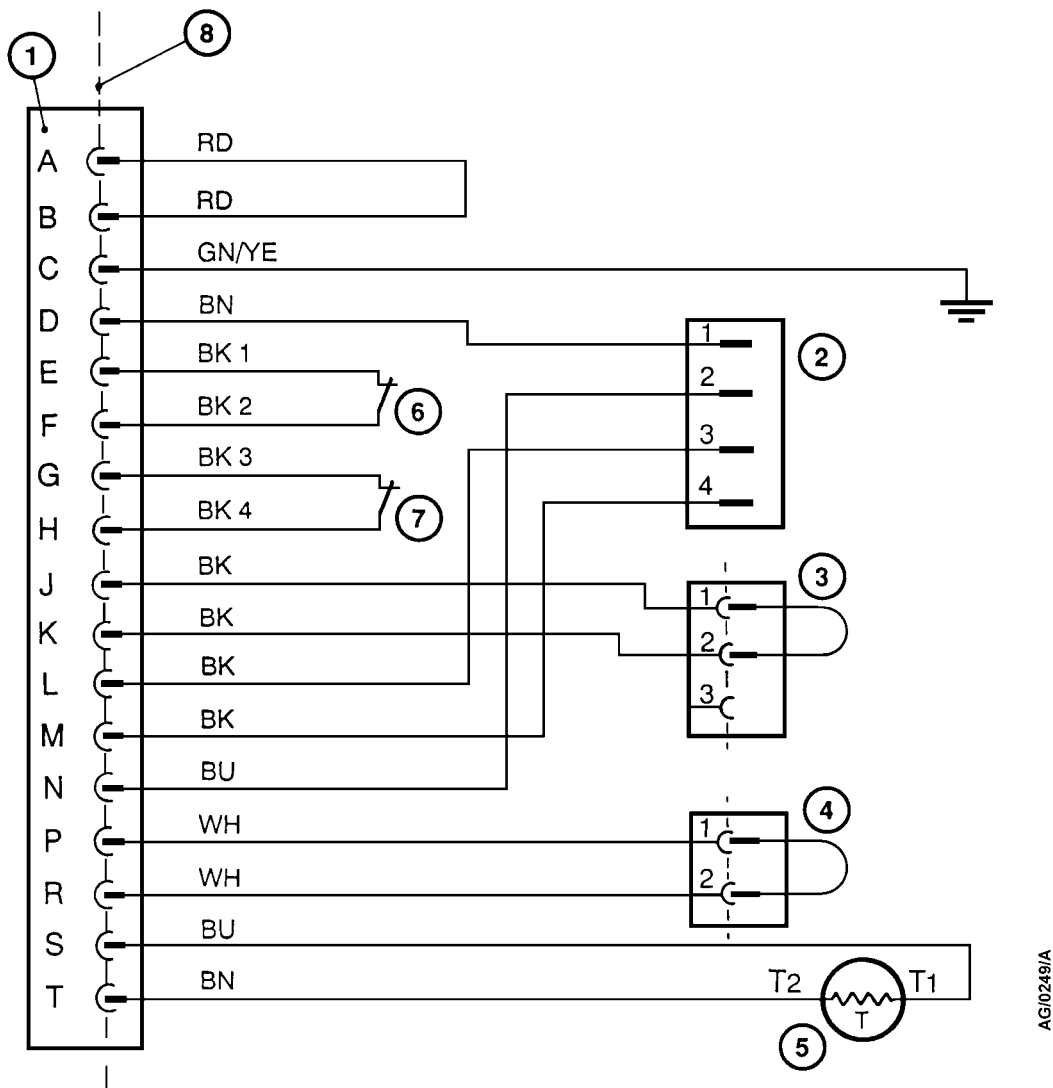

1. 17-way connector
2. Electrical connector (oil-level monitor)
3. Electrical connector (flow-switch)
4. Electrical connector (QMB thermistors)
5. QDP thermistors
6. Warning thermal snap-switch
7. Shut-down thermal snap-switch
8. QDP electrical services panel

Wire colour codes:

- BK Black
- BN Brown
- BU Blue
- GN Green
- RD Red
- WH White
- YE Yellow

Figure 11 - 17-way connector wiring

AG/0249/A



Pins	Wire colour	Use
A and B	Red	Enclosure interlock and/or emergency off
C	Green/Yellow	Thermal snap-switch earth
D and N	D: brown, N: Blue	Oil-level monitor control (if required)
E and F	Black	Warning (88 °C) thermal snap-switch
G and H	Black	Shut-down (95 °C) thermal snap-switch
J and K	Black	Not assigned to a specific accessory
L and M	Black	Oil-level monitor outputs
P and R	White	QMB motor-protection thermistor outputs
S and T	S: Blue, T: Brown	QDP motor-protection thermistor outputs

Table 5 - 17-way connector pins

### 3.7.2 High and low voltage operation

The universal voltage and frequency motors are supplied configured for 'low voltage' operation (200-208 V at 50 Hz or 200-230 V at 60 Hz). Figures 12 and 14 show the low voltage configurations for the QDP40 and QDP80 Pumps.

To change the QDP40 Pump-motor to 'high voltage' operation (380-415 V at 50 Hz or 460 V at 60 Hz), remove the pump-motor terminal-box cover, then remove the three links from the U, V and W terminals. Link the U1, V1 and W1 terminals as shown in Figure 13.

To change the QDP80 Pump-motor to 'high voltage' operation, remove the pump-motor terminal-box cover, then remove the wires from the U1, V1 and W1 terminals. Reconnect the wires to the W2, U2 and V2 terminals as shown in Figure 15.

### 3.7.3 Connect the electrical supply

#### CAUTION

The motor must be correctly configured and you must make the correct electrical connections for your electrical supply. If you do not, you can damage the motor.

Connect the motor to the electrical supply as described below. Connect the supply through a contactor which has overload-protection, or use a controller which incorporates a contactor. You must use a contactor which has a manual reset control. If you do not, the pump could automatically restart after an electrical overload or an electrical supply failure.

1. Remove the motor terminal-box cover.
2. Check your electrical supply voltage and frequency. If necessary, configure the motor to operate with your supply voltage (see Section 3.7.2).
3. Remove the plug from the cable entry-hole.

4. Fit a suitable 20 mm cable-gland to the hole. If your cable is too large to pass through a 20 mm cable-gland, fit a 20 mm to 25 mm female thread-adaptor to the cable entry-hole, and fit a 25 mm cable-gland to the adaptor. The cable-gland (and adaptor, if fitted) must provide a protective seal to IP44 (or higher), as defined by IEC 529.
5. Pass the supply cable through the cable-gland and connect the wires of the electrical supply cable to the appropriate terminals (see Figures 12 to 14).
6. Tighten the cable-gland and refit the terminal-box cover.

### 3.7.4 Connect the thermal snap-switches

#### WARNING

Incorporate a manual reset device in your control equipment. If you do not (and a fault which causes the shut-down thermal snap-switch to open is not corrected), the pump will switch on again when it cools down.

You can connect the warning thermal snap-switch to your control equipment to provide an indication that the pump is too hot. Connect the shut-down thermal snap-switch to your control equipment to shut down the pump. Alternatively, you can connect the shut-down thermal snap-switch to the electrical-overload control-loop of your contactor. If you do this, the contactor will automatically switch off if the pump is too hot.

The thermal snap-switches will reset (that is, close again) when the pump cools down to a preset temperature (see Section 2). We therefore recommend that your control equipment incorporates a manual reset device to prevent the pump switching on again automatically when it cools down.

You can use a 17-way connector mating-half (not supplied: refer to Section 7.3) to connect the thermal snap-switches to your control equipment; Table 5 defines the functions of the pins.

### 3.7.5 Connect the motor-protection thermistors

Connect the output of the motor-protection thermistors to your control equipment to switch off the pump if the motor is too hot. Refer to Section 2 for the specification of a suitable control-unit. You can use a 17-way connector mating-half (not supplied: refer to Section 7.3) to connect the thermistors outputs to your control equipment; Table 5 defines the functions of the pins.

If you have a QMB mechanical booster pump in your pumping system, then :

- If you connect the QDP and QMB thermistors to a single control-unit (for example, an Edwards Q Controller), you must connect the outputs in series not in parallel. The outputs must not be short-circuited by any links or jumpers.
- If you connect the QMB thermistor outputs directly to an Edwards Q Controller (that is, you do not use the 17-way connector on the QDP), either make sure that pins P and R on the electrical connector on the QDP are not connected to the auxiliary socket of the Q Controller, or make sure that the mating-half of the 2-way QMB thermistors electrical connector is removed (refer to Section 3.7.1).

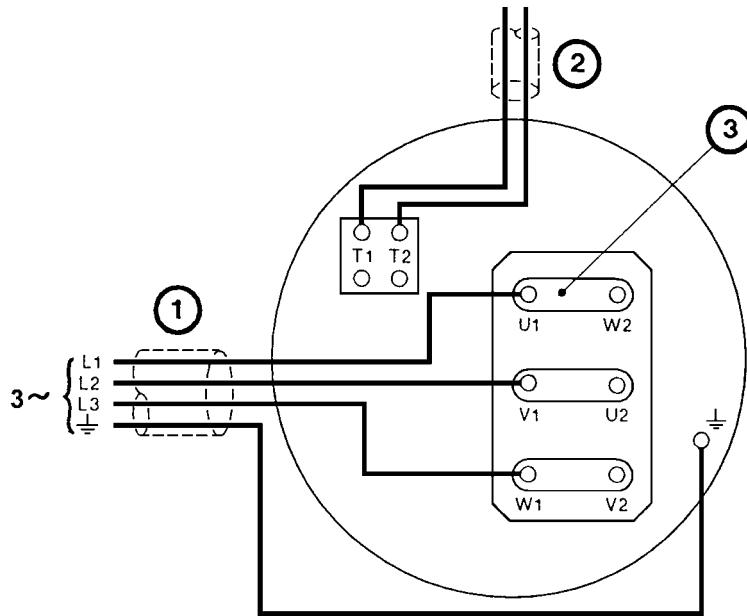

AW/1897/A

1. To electrical supply
2. To 17-way connector on electrical services panel
3. Links

Figure 12 - QDP40 low voltage configuration

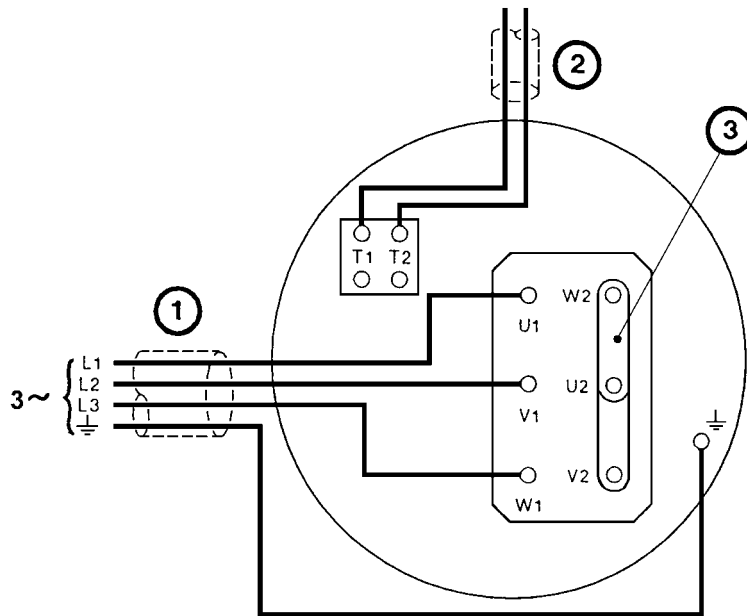

AW/1898/A

1. To electrical supply
2. To 17-way connector on electrical services panel
3. Links

Figure 13 - QDP40 high voltage configuration

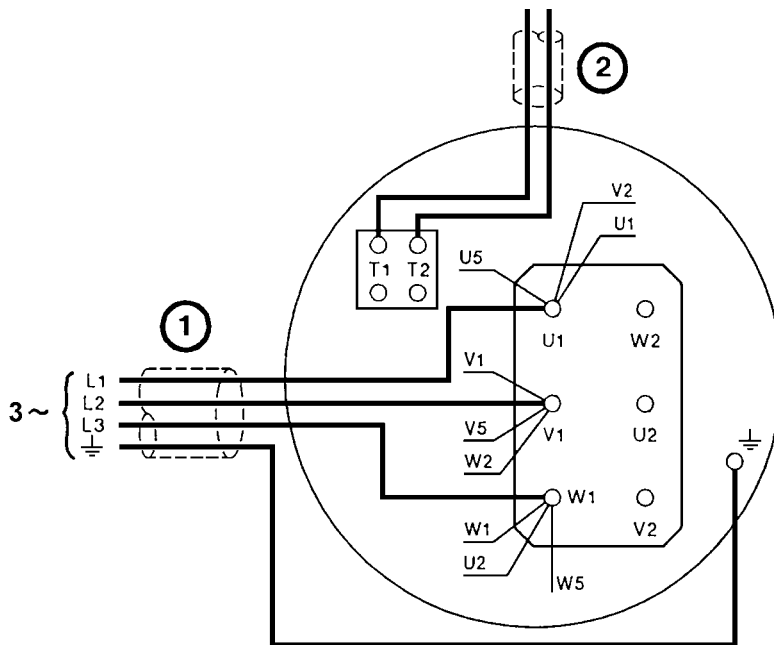

AW/1899/A

1. To electrical supply
2. To 17-way connector on electrical services panel

Figure 14 - QDP80 low voltage configuration

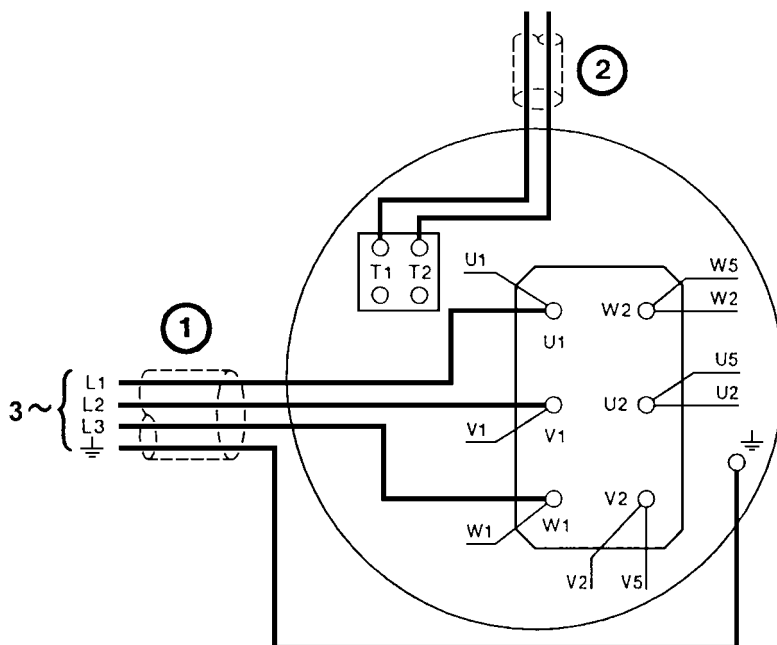

AW/1900/A

1. To electrical supply
2. To 17-way connector on electrical services panel

Figure 15 - QDP80 high voltage configuration

### 3.7.6 Check the pump rotation

Check the direction of pump rotation as described below.

1. Loosen the bolts which secure the blanking-plate to the pump-inlet.
2. Watch the pump-inlet blanking-plate and switch on the pump for one or two seconds, then switch the pump off. If the blanking-plate lifts from the inlet, the direction of rotation is incorrect. If the direction of rotation is incorrect, isolate the electrical supply and reverse any two of the electrical supply phase-wires in the pump-motor terminal-box.
3. Repeat the check to ensure that the direction of rotation is correct.

### 3.8 Fit a mechanical booster pump

If you want to use a mechanical booster pump, fit it now. Details of the connection kits available from Edwards are given in Section 7. Refer to the installation procedures in the instruction manual supplied with the connection kit.

### 3.9 Connect the cooling-water supply

#### WARNING

Do not turn on the cooling-water supply until after you complete the electrical installation of the pump. If you do, condensation may form inside the motor terminal-box and there may be a risk of electric shock.

#### CAUTION

Drain the cooling-water from the pumping system, if you will transport or store it in conditions where the cooling-water could freeze. If you do not, cooling-water may freeze in the QDP pump and damage the pump.

*Note: If you will transport or store the pumping system in conditions where the cooling-water could freeze, you must ensure that all cooling-water is drained from the pumping system : refer to Section 6.1*

Connect the cooling-water supply as described below. If a QMB mechanical booster pump is fitted, you must connect the QMB cooling-water supply and return to the cooling-water manifold on the QDP as described in the instruction manual supplied with the QMB Connection Kit. When you connect the hoses between the QDP cooling-water manifold and the QMB pump, remove only the  $\frac{3}{8}$  BSP caps on the manifold (Figure 10, items 11 and 12). Do not remove the  $\frac{3}{8}$  to  $\frac{1}{4}$  inch reducer fittings on the manifold.

If you need to connect more than one QDP pump to the water supply, you must connect them in parallel and not in series.

1. Take out the male and female type quick-release connectors from the general fitting-kit.
2. Fit these connectors to your cooling-water supply and return hoses with  $\frac{3}{8}$  inch BSP male pipe fittings (which you must supply). Fit the female quick-release connector to the water supply hose and fit the male quick-release connector to the water return hose.
3. Remove the dust-caps from the cooling-water connectors on the water services panel (Figure 2, items 4 and 6).
4. Connect your water return pipe to the water return connector on the water services panel, then connect your water supply pipe to the water supply connector on the water services panel.
5. Turn on the cooling-water supply.
6. To bleed air out of the water cooling system, use a screwdriver to lift up the spindle on the top of the TCV (Figure 10, item 8) and hold it up for 15 to 30 seconds to allow a steady flow of water to establish. Do not turn the spindle against the locking-wire.
7. Check the water hoses, pipelines and connections to ensure that there are no leaks.
8. Turn off the water supply while you complete the remainder of the installation procedures.

### 3.10 Connect the nitrogen supply

#### WARNING

If your vacuum system is not suitable for pressures above atmospheric, you must install a suitable control-valve system. If you do not, your system could be pressurised up to the nitrogen supply pressure.

Connect nitrogen supplies to the pump through the five connectors on the gas services panel (see Figure 2). You must connect a nitrogen supply to the shaft-seals purge connector (Figure 2, item 12) for all QDP pump applications. Use the other gas pipelines according to your application.

The gas pipeline connections are  $\frac{1}{4}$  inch compression fittings. Use rigid metal supply pipelines (such as stainless steel) with an outside diameter of  $\frac{1}{4}$  inch. If you have an acoustic enclosure to fit, ensure that the pipelines will not obstruct the enclosure. Use the connectors in the general fitting-kit to connect your pipelines to the pump. If you have a gas module accessory, the necessary pipelines and connectors are supplied with the accessory.

Use a suitable regulator in the nitrogen supply pipeline to the shaft-seals purge to maintain a constant supply pressure of 8 psig (0.55 bar gauge,  $3.8 \times 10^3$  Pa) minimum and 10 psig (0.69 bar gauge,  $6.9 \times 10^4$  Pa) maximum.

If your vacuum system is not suitable for positive pressures, install an inlet-valve or nitrogen supply solenoid-valve, interlocked to the pump-motor electrical supply, to prevent over-pressurisation. To prevent over-pressurisation of the exhaust-line, install a facility to monitor the exhaust pressure and to cut off the nitrogen supply automatically if this pressure reaches 6 psi ( $4.1 \times 10^4$  Pa).

### 3.11 Connect the pump to your vacuum system

When you connect your pump to the vacuum system, take note of the following:

- To get the best pumping speed, ensure that the pipeline which connects the vacuum system to the pump is the minimum length possible and has an internal diameter not less than the pump-inlet port. Use a flexible connection in the pipeline to reduce vibration and stress in the system pipelines.
- On very dusty applications, use an inlet-filter to minimise damage to the pump.
- You must be able to isolate the pump-inlet from the atmosphere and from your vacuum system if you have pumped or produced corrosive chemicals.
- Vacuum pipelines must be adequately supported to stop the transmission of stress to pipeline joints.

The QDP40 inlet-flange is ISO40 and the QDP80 inlet-flange is ISO63. Use the following procedure to connect the QDP pump to your vacuum system. This procedure assumes that a mechanical booster pump has not been fitted. If a mechanical booster pump has been fitted, use the instructions given in the appropriate instruction manual supplied with the mechanical booster pump.

1. Remove the four M8 x 45 mm cap-head bolts, nuts and washers. Remove the inlet blanking-plate.
2. Retain the nuts, bolts and washers for future use.
3. Use the trapped 'O' ring supplied to connect the pump inlet-flange to your vacuum system. Secure with the bolts provided in the general fitting-kit or the bolts removed in Step 1.

### 3.12 Exhaust system connection

#### 3.12.1 Use of the alternative outlet position

Figures 3 and 4 show the positions of the outlet on the QDP pump; as supplied, the outlet is at the motor end of the pump. If required, the outlet can be moved to the opposite end of the pump. Use the following procedure to use the alternative outlet position.

1. Remove the two screws (Figure 2, item 7) which secure the exhaust-silencer support-plate to the pump and remove the support-plate.
2. Undo and remove the NW40 clamp which secures the inlet of the exhaust-silencer to the outlet of the pump.
3. Remove the exhaust-silencer and turn it through 180°, so that the outlet is at the other end of the pump (as in Figures 3 and 4).

4. If required, you can remove the adaptor (Figure 4, item 3) from the exhaust-silencer on the QDP80 pump. To remove the adaptor:
  - Remove the two NW40 clamps which secure the adaptor to the outlet of the exhaust-silencer and the elbow and remove the adaptor.
  - Use one of the clamps to secure the elbow to the outlet of the exhaust-silencer.
5. Use the clamp removed in Step 2 to secure the inlet of the exhaust-silencer to the outlet of the pump.
6. Refit the exhaust-silencer support-plate and secure with the two screws removed in Step 1.

### 3.12.2 Connect the pump to your exhaust system

**WARNING**

Pipe the exhaust to a suitable treatment plant to prevent the discharge of dangerous gases or vapours to the surrounding atmosphere.

**WARNING**

Do not operate the QDP pump with the exhaust pipeline blocked. If the exhaust pipeline is blocked, the QDP pumps can generate exhaust pipeline pressures up to 7 bar ( $7 \times 10^5$  Pa).

**CAUTION**

Use a catchpot to prevent condensate draining back into the pump. Condensate which drains back into the pump could damage the pump.

When you connect the pump to the exhaust system, take note of the following:

- Ensure that all components in the exhaust pipeline have a pressure rating which is greater than the highest pressure that can be generated in your system.
- Incorporate flexible pipelines in the exhaust pipeline to reduce the transmission of vibration and to prevent loading of coupling-joints. We recommend that you use Edwards flexible pipelines.
- You must be able to isolate the exhaust-silencer outlet from the atmosphere if you have pumped or produced corrosive chemicals.
- Exhaust pipelines must be adequately supported to stop the transmission of stress to pipeline joints.

Connect the exhaust-silencer outlet to your exhaust system. The outlet has an NW40 flange.



### 3.13 Leak-test the installation

#### WARNING

Leak-test the system after installation and maintenance and seal any leaks found to prevent leakage of dangerous substances out of the system and leakage of air into the system.

Leak-test the system after installation and seal any leaks found. Dangerous substances which leak from the system will be dangerous to people and there will be a danger of explosion if air leaks into the system. We recommend that the leak rate is  $1 \times 10^{-5}$  mbar.l.s<sup>-1</sup> ( $1 \times 10^{-3}$  Pa.l.s<sup>-1</sup>) helium or less.

### 3.14 Commission the pump

#### 3.14.1 Adjust the thermostatic control-valve (TCV)

#### WARNING

Do not adjust the TCV to a lower setting (that is, turn the adjuster spindle anticlockwise) when the pump is hot. This will increase the flow of cooling-water which may damage the pump because of the differential contraction of the pump rotor and case.

*Note: The QDP pump can only be operated at pump temperatures above 88 °C if you configure the pump so that the 88 °C thermal snap-switch gives a warning only, (that is, does not automatically shut down the QDP pump), or if you fit the high temperature thermal snap-switch kit, which contains a warning thermal snap-switch which opens at 95 °C and a shut-down thermal snap-switch which opens at 115 °C.*

The TCV regulates the flow of water through the water cooling system to maintain the pump at the required operating temperature.

A pump operating temperature of 70 °C is suitable for most processes and, as supplied, the TCV is factory set to maintain this temperature (measured at the thermal snap-switch position). The adjuster spindle on the TCV is held at this setting by a locking-wire.

You can adjust the TCV to vary the operating temperature of the pump (measured at the temperature measurement point - Figure 10, item 16) between approximately 55 °C (minimum) and approximately 90 °C (maximum). If you need to adjust the TCV to suit your operating conditions, refer to Figure 10 and use the following procedure. Note that it takes approximately 30 minutes for the pump to stabilise at its final operating temperature.

1. Cut and remove the locking-wire on the spindle on the top of the TCV (8).

- Use a suitable screwdriver to turn the spindle (8) the necessary number of turns from the factory set position to select the required operating temperature (refer to Table 6 for the QDP40 and Table 7 for the QDP80). If you are not sure whether the adjuster spindle is at the factory set position, turn the spindle fully clockwise until it will turn no further, then adjust the spindle from this position.

Required pump operating temperature °C	Required number of turns of TCV adjuster spindle	
	From factory set position	From fully clockwise position
Valve shut/pump off	10	-
90 #	9 } Clockwise	1 } Anti-clockwise
70 *	-	10 } Anti-clockwise
55	6 Anticlockwise	16 }

# 88 °C thermal snap-switch must be configured to provide warning only, or you must fit the high temperature thermal snap-switch kit.

\* Factory set position

Table 6 - Adjust the TCV on the QDP40

Required pump operating temperature °C	Required number of turns of TCV adjuster spindle	
	From factory set position	From fully clockwise position
Valve shut/pump off	13	-
90 #	9 } Clockwise	4 } Anti-clockwise
70 *	-	13 } Anti-clockwise
55	8 Anticlockwise	21 }

# 88 °C thermal snap-switch must be configured to provide warning only, or you must fit the high temperature thermal snap-switch kit.

\* Factory set position

Table 7 - Adjust the TCV on the QDP80

### 3.14.2 Commissioning procedure

- Isolate the pump from your vacuum system.
- Turn on the cooling-water supply, the nitrogen supply and your exhaust-extraction system (if fitted).
- Check all of the water, nitrogen system, exhaust-extraction system and vacuum system connections.
- Switch on the pump (and the mechanical booster pump, if fitted).
- Allow the pump temperature to stabilise (approximately 30 minutes).
- Turn off the pump and the services.

## 4 OPERATION

*Note: The following procedures assume that you have an inlet-isolation valve fitted to your pump.*

### 4.1 Start-up procedure

1. Check the gearbox oil-level in the sight-glass on the side of the pump (see Figure 10).
2. Check the coolant level with the filler-cap/level indicator.
3. Turn on the cooling-water supply, the nitrogen supply and the exhaust-extraction system (if fitted).
4. Check all of the water, nitrogen system, exhaust-extraction system (if any) and vacuum system connections.
5. Switch on the pump (and the mechanical booster pump, if fitted).
6. Refer to Section 2.3 and Section 4.2 for operation of the gas system to suit your process conditions.

### 4.2 Gas flow rates and pressures

Table 2 (see Section 2) shows the maximum flow rates for the shaft-seals purge, 3/4-interstage purge and 2/3-interstage purge gas flows.

During operation, you must set the flow rates of the 3/4-interstage purge and the 2/3-interstage purge pipelines to the required values. These values are dependent on the process in which the pump is used and you should adjust the flow rates according to your experience. If you exceed the flow rates specified in Table 2, the performance of the pump may be reduced.

You must set the pressure of the shaft-seals purge as specified in Table 2 and Section 3.10. You must not attempt to adjust the flow rate of the shaft-seals purge (which is determined by the pump itself). The nominal flow rate of the shaft-seals purge is  $12 \text{ l.min}^{-1}$ . If the flow rate is higher than the nominal value, you may reduce the flow rate of the 3/4-interstage purge by  $[F-12] \text{ l.min}^{-1}$  (where F is the actual shaft-seals flow rate). This will reduce the amount of nitrogen exhausted from the pump.

### 4.3 Pump shutdown

Shut down the pump as described below.

1. Isolate the pump-inlet from your vacuum system and operate it for 15 minutes with the nitrogen supply switched on.
2. Turn off the nitrogen supply.
3. Switch off the QDP pump (and the mechanical booster pump if fitted).
4. Turn off the cooling-water supply.

## 5 MAINTENANCE

### 5.1 Safety

#### WARNING

Obey the safety instructions given below and take note of appropriate precautions. If you do not, you can cause injury to people and damage to equipment.

- A suitably trained and supervised technician must maintain the QDP pump.
- Ensure that the maintenance technician is familiar with the safety procedures which relate to the products handled by the pumping-system. Wear the appropriate safety-clothing when you come into contact with contaminated components. Dismantle and clean contaminated components inside a fume-cupboard.
- Allow the pump to cool to a safe temperature before you start maintenance work.
- Vent and purge the pumping system with nitrogen before you start any maintenance work.
- Isolate the pump and other components in the pumping system from the electrical supply so that they can not be operated accidentally.
- Recheck the pump rotation direction if the electrical supply has been disconnected.
- Do not reuse 'O' rings.
- Dispose of components, grease and oil safely (see Section 6.2).
- Take care to protect sealing-faces from damage.
- Do not touch or inhale the thermal breakdown products of fluorinated materials which may be present if the pump has been overheated to 260 °C and above. These breakdown products are very dangerous. Fluorinated materials in the pump may include oils, greases and seals. The pump may have overheated if it was misused, if it malfunctioned or if it was in a fire. Edwards Health and Safety Data sheets for fluorinated materials used in the pump are available on request: contact your supplier or Edwards.
- Leak-test the system after maintenance work is complete if you have connected or disconnected any vacuum or exhaust joints. Seal any leaks found to prevent leakage of dangerous substances out of the system and leakage of air into the system.

### 5.2 Maintenance plan

The plan in Table 8 details the maintenance operations we recommend to maintain the pump in normal operation. Instructions for each operation are given in the section shown.

When you maintain the pump, use Edwards maintenance and service kits. These contain all of the necessary seals, lubricating grease and other components necessary to complete maintenance operations successfully. The Item Numbers of the service kits are given in Section 7.2.

In practice, the frequency of maintenance is dependent on your process. In clean processes, you may be able to decrease the frequency of maintenance operations; in harsh processes you may have to increase the frequency of maintenance operations. Adjust the maintenance plan according to your experience.

Operation	Frequency	Refer to Section
Check the gearbox oil-level	6 Monthly	5.3
Check the coolant-level	6 Monthly	5.4
Inspect and clean the exhaust-silencer	3 Monthly	5.5
Inspect the pipelines and connections	6 Monthly	5.6
Inspect the exhaust check-valve	6 Monthly	5.7
Change the gearbox oil	Yearly or when contaminated, whichever occurs first*	5.8
Relubricate the rotor bearings	Yearly	5.9

\* If the gearbox oil is not contaminated, you may only need to change the gearbox oil once a year. If there is contamination (indicated by a change in colour of the oil; for example, water contamination will turn the oil a white colour), you must change the oil. You may be able to remove the contaminants from the oil by filtration.

Table 8 - Maintenance plan

### 5.3 Check the gearbox oil-level

**WARNING**

Do not remove the oil filler-plug when the pump is operating. If you do, hot oil may be ejected from the pump gearbox

Refer to Figure 10 and check that the pump gearbox oil-level is between the MIN and MAX marks on the bezel of the oil-level sight-glass. If the oil-level is above the MAX mark, drain excess oil from the pump as described in Section 5.7 until the oil-level is correct. If the oil-level is below the MAX mark:

1. Unscrew and remove the oil filler-plug (3).
2. Pour oil into the gearbox until the oil-level is at the MAX mark on the bezel of the oil-level sight-glass.
3. Make sure that the bonded seal is in place on the oil filler-plug. Screw the filler-plug back in and tighten to finger tight. Use a spanner to tighten a further  $\frac{1}{16}$ th of a turn.

The gearbox is vented and the loss of a small amount of oil during operation is normal. If you need to pour oil into the gearbox frequently, or if there is a sudden loss of a large amount of oil, this may indicate that the pump has a fault. In these circumstances, we recommend that you shut down the pump as soon as possible and contact your supplier or Edwards for advice.

## 5.4 Check the coolant-level

### WARNING

Do not remove the combined filler-plug/level indicator when the QDP pump is hot. If you do, hot coolant may be ejected from the header-tank and could cause injury.

### CAUTION

Fill the QDP pump with the correct type and amount of coolant. If you do not, the pump may overheat and it may not work correctly.

In addition to cooling the pump, the coolant acts as a corrosion inhibitor and anti-scaling agent. Check the coolant-level and fill the pump with coolant as described below; new coolant is available as a spare: refer to Section 7. The locations of the components of the cooling-water system are shown in Figure 10.

1. Isolate the pump from the electrical supply and ensure that the cooling-water supply is off.
2. Unscrew and remove the combined filler-plug/level indicator (5). Use a clean lint-free cloth to wipe the shaft of the indicator, then replace the combined filler-plug/level indicator in the coolant header-tank.
3. Remove the combined filler-plug/level indicator again and check the coolant-level: the coolant-level must be visible on the shaft of the indicator, but must not be above the notch mark on the indicator shaft. If the coolant-level is acceptable, continue at Step 12, otherwise continue at Step 4.
4. Remove the cap from a container of pump coolant and pour in de-ionised water until the 2.1 litre fill line on the container is reached.
5. Refit the cap firmly on the container. Shake the container gently to fully mix the fluids.
6. Check that the coolant drain-plug on the underside of the pump is securely fitted.
7. Fit a length of transparent flexible hose to the air bleed-valve, then unscrew the air bleed-valve (7).
8. Use a clean funnel to slowly fill the pump with the coolant mixture until the coolant fluid starts to flow through the hose fitted to the air bleed-valve.
9. Tighten the air bleed-valve (7), then remove the flexible hose.
10. Continue to fill the system slowly until you see the fluid in the bottom of the coolant header-tank (4).
11. Refit the combined filler-plug/level indicator (5) and then remove it to check the fluid-level on the shaft of the indicator: refer to Step 3.
12. Check that the bonded seal on the combined filler-plug/level indicator (5) is in place. Refit and tighten the combined filler-plug/level indicator.

## 5.5 Inspect and clean the exhaust-silencer

### WARNING

Substances which accumulate in the exhaust-silencer may be dangerous. Do not allow these substances to come into contact with your skin or eyes. Do not inhale vapours from these substances. Fit blanking caps to the inlet and outlet flanges when you move the silencer around your workplace.

Refer to Figure 16 and dismantle, inspect and clean the silencer as described below.

1. Release the NW40 clamps at the silencer inlet and outlet flanges to disconnect the silencer from the check-valve and the pump.
2. Slide the silencer out towards the high-vacuum end of the pump to remove the silencer from the pump. Alternatively, undo the two support-plate retaining screws (see Figure 2) and slide the silencer complete with the support-plate towards the motor end of the pump.
3. Weigh the silencer. If the mass of the silencer is greater than 7.5 kg, dismantle, clean and reassemble the silencer as in Steps 4 to 9 below. If you do not need to clean the silencer, refit the silencer as in Step 12.
4. Remove and retain the six bolts and washers which secure each end-cover plate to the silencer body. Pull the end-cover plates squarely from the outlet pipe to remove them.
5. Remove the three 'O' rings from the silencer and discard.
6. Empty all loose deposits from the silencer body; take care not to damage the end-cover plate sealing surfaces.
7. Use a suitable tool to dislodge remaining deposits, then wash the silencer body with steam or water. Finally, glass-bead blast the silencer body. If required, use a cleaning solution suitable for the nature of the deposits.
8. Inspect the silencer for internal corrosion and check that the wall of the silencer body is not excessively eroded. Inspect the end-cover plate and inlet and outlet flange sealing-faces for damage and refinish if necessary. If silencer damage is excessive, it should be replaced.
9. Check that the 'O' ring grooves are clean. Apply a light wipe of vacuum grease and place the new 'O' rings in position.
10. Refit the end-cover plates and secure with the bolts and washers removed in Step 3. Tighten the bolts progressively; alternate between bolts on opposite sides of the end-cover plate. Tighten to a torque of 10 Nm.
11. Leak-test the silencer.
12. Slide the silencer in from the high-vacuum end of the pump. Alternatively, slide the silencer complete with the support-plate in from the motor end of the pump and tighten the support-plate retaining screws (see Figure 2).
13. Reconnect the silencer to the pump and the check-valve with the new NW40 clamps and trapped 'O' rings supplied in the servicing kit.

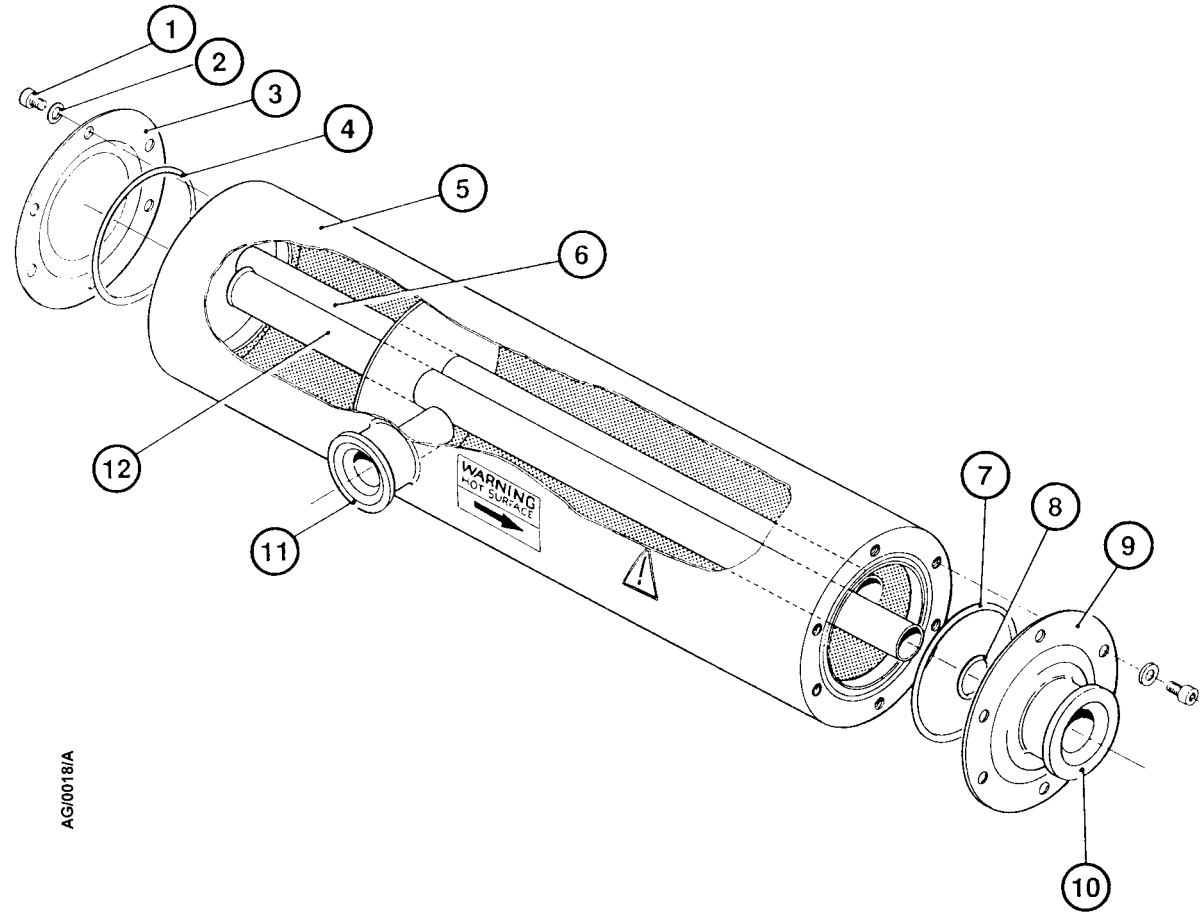

- |                    |                    |
|--------------------|--------------------|
| 1. Cap-head bolt   | 7. 'O' ring        |
| 2. Washer          | 8. 'O' ring        |
| 3. End-cover plate | 9. End-cover plate |
| 4. 'O' ring        | 10. Outlet flange  |
| 5. Silencer body   | 11. Inlet flange   |
| 6. Transfer tube   | 12. Outlet tube    |

Figure 16 - Exhaust silencer



## 5.6 Inspect the pipelines and connections

1. Inspect all cooling-water connections and check that they are secure; tighten any loose connection. Inspect all cooling-water pipelines and connections for corrosion, leaks and damage. Repair or replace any corroded or damaged components and seal any leaks found.
2. Inspect all nitrogen supply connections and check that they are secure; tighten any loose connection. Inspect all nitrogen supply pipelines and connections for leaks and damage. Repair or replace any corroded or damaged components and seal any leaks found.
3. Inspect all electrical connections and check that they are secure; tighten any loose connection. Inspect all electrical cables and check that they are not damaged and have not overheated. Repair or replace any cable that is damaged or has overheated.
4. Inspect all vacuum connections and check that they are secure; tighten any loose connection. Inspect all vacuum pipelines for corrosion and damage and check that they do not leak. Repair or replace any corroded or damaged components and seal any leaks found.

## 5.7 Inspect the exhaust check-valve

### WARNING

Substances which accumulate in the check-valve may be dangerous. Do not allow these substances to come into contact with your skin or eyes. Do not inhale vapours from these substances. Fit blanking caps to the inlet and outlet flanges when you move the check-valve around your workplace.

You must remove the exhaust check-valve from the silencer and your exhaust-extraction system before you can inspect it. It is convenient, therefore, to inspect the exhaust check-valve at the same time as you inspect the exhaust-silencer (see Section 5.5).

Use the procedure below to remove and inspect the valve. This procedure assumes that the exhaust-silencer has already been disconnected from the pump and the exhaust check-valve has been removed. Figure 17 shows the component parts of the exhaust check-valve.

1. Release the NW40 clamp at the exhaust check-valve outlet flange and remove the check-valve from the system pipeline.
2. Unscrew the two halves of the check-valve body; use a strap wrench if necessary.
3. Remove the fluoroelastomer ball and the 'O' ring.
4. Use a cleaning solution suitable for the process products pumped to clean the valve body and the fluoroelastomer ball. If necessary, replace the fluoroelastomer ball with a new one.
5. Inspect the 'O' ring groove and the KF40 flange sealing-faces for damage and refinish if necessary.
6. Apply a light wipe of vacuum grease and position the 'O' ring in its groove in the valve body.

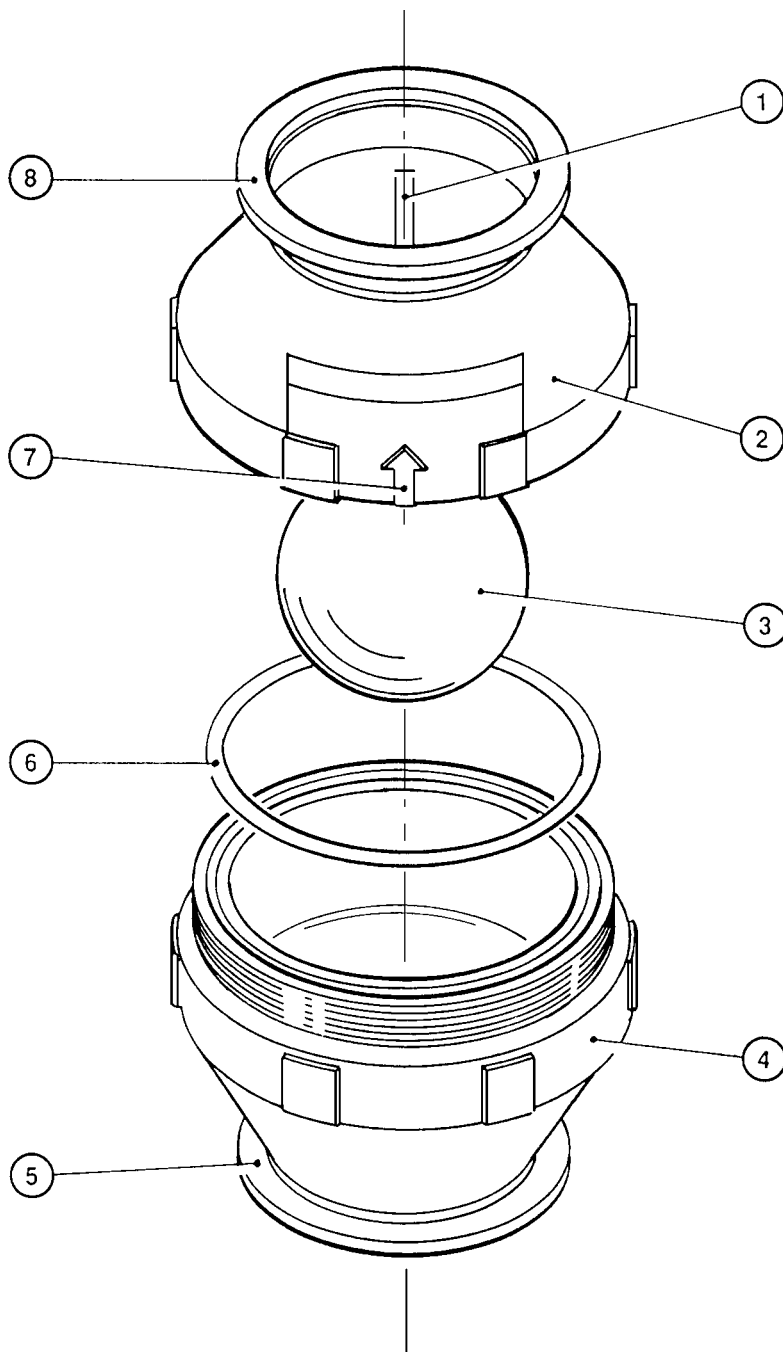

AC/0019/A

- |                         |                             |
|-------------------------|-----------------------------|
| 1. Spider leg           | 5. Inlet-flange             |
| 2. Valve body (female)  | 6. 'O' ring                 |
| 3. Fluoroelastomer ball | 7. Mounting direction arrow |
| 4. Valve body (male)    | 8. Outlet-flange            |

Figure 17 - Exhaust check-valve

7. Ensure that the fluoroelastomer ball is positioned correctly and screw the two halves of the valve body together.
8. Refit the valve to the system pipeline with the NW40 clamp and trapped 'O' ring. Ensure that the flow direction arrow points away from the silencer (towards your exhaust-extraction system).

## **5.8 Change the gearbox oil**

1. Remove the oil filler-plug (see Figure 10).
2. Use a suitable pump or syringe to suck the oil out of the gearbox.
3. Discard the old bonded seal on the oil filler-plug and replace with a new one from the pump maintenance kit.
4. Fill the gearbox through the filler hole, with the correct grade and quantity of oil. Allow the oil to drain into the gearbox and then check the level on the oil sight-glass (refer to Section 3.5).
5. Ensure that the new bonded seal is positioned correctly and refit the oil filler-plug.

## **5.9 Relubricate the rotor bearings**

Relubricate the rotor bearings as described below. Figure 18 shows the location of the rotor bearings components.

1. Remove the six screws (2) which secure the bearing end-cover (1) to the high vacuum head-plate (4).
2. Lift away the end-cover and remove the sealing 'O' ring (3). Dispose of the 'O' ring (see Section 6.2).
3. Use a clean lint-free cloth or a plastic or wooden spatula to remove as much old grease as possible from the end-cover and bearings. Do not use your fingers for this operation.
4. Inspect the bearings for obvious signs of wear or the presence of debris. If the bearings are worn, return the pump to an Edwards Service Centre for repair.
5. If the bearings are in a satisfactory condition, force new PFPE grease (supplied in the maintenance kit) into the bearings so that a smooth layer of grease covers the case and bearings. Do not over-pack the bearings or the pump will run hot.
6. Apply a light wipe of PFPE grease to the new 'O' ring seal and position it in its groove in the head-plate. Refit the end-cover to the high vacuum head-plate.

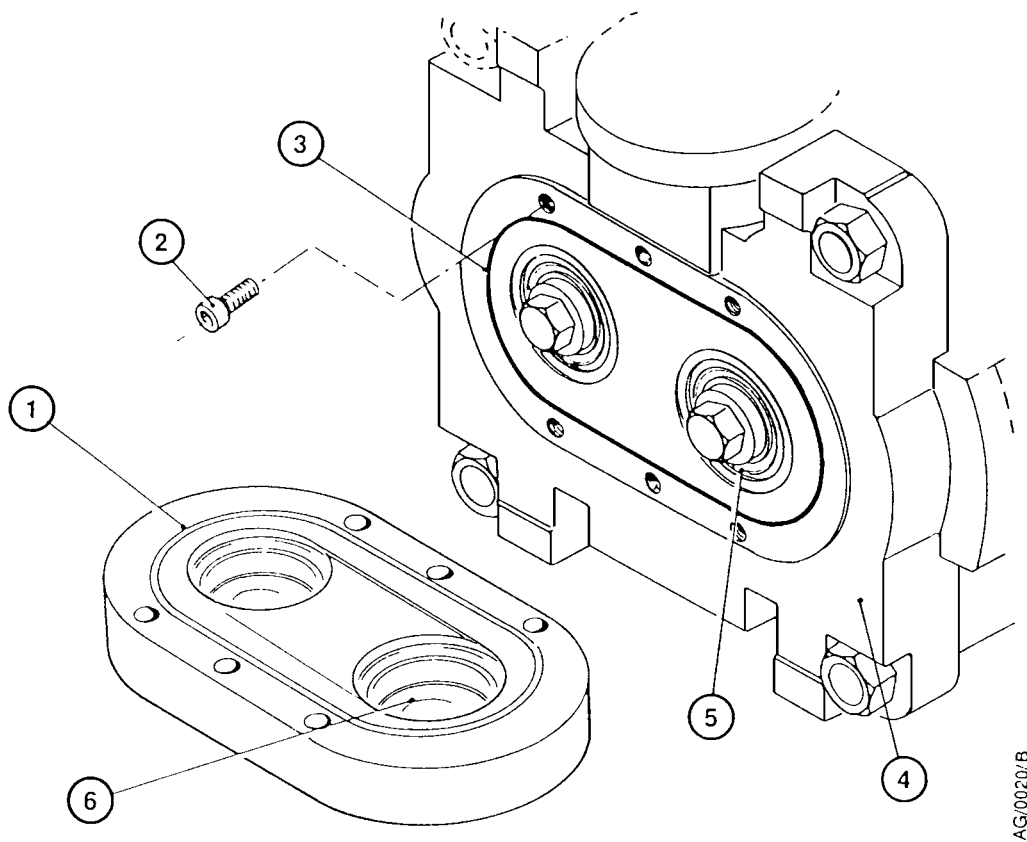

- |                             |                           |
|-----------------------------|---------------------------|
| 1. Bearing end-cover        | 4. High vacuum head-plate |
| 2. End-cover securing screw | 5. Bearing                |
| 3. 'O' ring                 | 6. End-cover cavity       |

Figure 18 - Rotor bearing relubrication

## 6 STORAGE AND DISPOSAL

### 6.1 Storage

**CAUTION**

Drain the cooling-water from the pumping system, if you will transport or store it in conditions where the cooling-water could freeze. If you do not, cooling-water may freeze in the QDP pump and damage the pump.

If you will transport or store the pumping system in conditions where the cooling-water could freeze (for example, if you transport the pump as air freight), you must ensure that all cooling-water is drained from the pumping system.

Use the following procedure :

1. Remove the cooling-water connectors from the pump, or attach an open pair of quick-connector halves to the connectors on the pump.
2. Blow compressed air through the cooling-water inlet, to force any water out of the cooling system.

Store the pump as follows :

1. If applicable, ensure that the pump has been shut down as described in Section 4.3 and disconnect all services, process and exhaust connections.
2. Fit blanking-plates to all vacuum inlets and outlets. Place protective covers over the pump services connection points.
3. Store the pump in clean dry conditions until required.
4. When required for use, prepare and install the pump as described in Section 3 of this manual.

### 6.2 Disposal

Dispose of the QDP pump and any components safely in accordance with all local and national safety and environmental requirements.

Particular care must be taken with the following:

- Fluoroelastomers which may have decomposed as the result of being subjected to high temperatures
- Components which have been contaminated with dangerous process substances.

## 7 SPARES AND ACCESSORIES

### 7.1 Introduction

Edwards products, spares and accessories are available from Edwards companies in Belgium, Brazil, Canada, France, Germany, Hong Kong, Italy, Japan, Korea, Switzerland, United Kingdom, U.S.A and a worldwide network of distributors. The majority of these centres employ Service Engineers who have undergone comprehensive Edwards training courses.

Order spare parts and accessories from your nearest Edwards company or distributor. When you order, please state for each part required:

- Model and Item Number of your equipment
- Serial number (if any)
- Item Number and description of the part.

### 7.2 Spares

The spare parts listed below are available for the QDP pumps :

Product	Item Number
Pump routine maintenance kit	A526-40-820
Exhaust-silencer servicing kit	A386-11-820
Exhaust check-valve servicing kit	A440-03-820
Coolant	H128-10-002
Krytox 1525 oil (1 kg)	H113-09-018
Fomblin RT15 grease (100 g)	H113-50-003
Exhaust-silencer	A528-19-000
Exhaust check-valve	A440-03-000

### 7.3 Accessories

The accessories listed below are available for the QDP pumps. Each accessory contains all the necessary components for assembly and installation of the accessory. Full functional descriptions and installation details are included in the instruction manual supplied.

Accessory	Item Number
QDP High Temperature Thermal Snap-Switch Kit	A505-27-000
QDP Gas Module	A528-05-000
QDP Acoustic Enclosure for QDP40 with inlet manifold	A528-01-000
QDP Acoustic Enclosure for QDP80 with inlet manifold	A528-03-000
Q Series 3 Exhaust Pressure Module	A528-50-000
QMB Booster Connection Kit for QDP40/QMB250F	A528-31-000
QMB Booster Connection Kit for QDP40/QMB500F	A528-32-000
QMB Booster Connection Kit for QDP80/QMB250F	A528-33-000
QMB Booster Connection Kit for QDP80/QMB500F	A528-34-000
QDP Shaft-Seals Purge Module	A528-55-000
CDP Flap Valve	A504-51-000
17-way connector mating-half	A528-40-067





# Return of Edwards Equipment - Procedure (Form HS1)

## Introduction

Before you return your equipment you must warn your supplier if the substances you used (and produced) in the equipment can be dangerous. You must do this to comply with health and safety at work laws.

**You must complete the Declaration (HS2) on the next page and send it to your supplier before you dispatch the equipment.** If you do not, your supplier will assume that the equipment is dangerous and he will refuse to accept it. If the Declaration is not completed correctly, there may be a delay in processing your equipment.

## Guidelines

Take note of the following guidelines:

- Your equipment is '**uncontaminated**' if it has not been used or if it has only been used with substances that are not dangerous. Your equipment is '**contaminated**' if it has been used with any dangerous substances.
- If your equipment has been used with radioactive substances, you must decontaminate it before you return it to your supplier. You must send independent proof of decontamination (for example a certificate of analysis) to your supplier with the Declaration (HS2). Phone your supplier for advice.
- We recommend that contaminated equipment is transported in vehicles where the driver does not share the same air space as the equipment.

## PROCEDURE

Use the following procedure:

1. Contact your supplier and obtain a Return Authorisation Number for your equipment.
2. Turn to the next page(s), photocopy and then complete the Declaration (HS2).
3. Remove all traces of dangerous gases: pass an inert gas through the equipment and any accessories which will be returned to your supplier. Drain all fluids and lubricants from the equipment and its accessories.
4. Disconnect all accessories from the equipment. Safely dispose of the filter elements from any oil mist filters.
5. Seal up all of the equipment's inlets and outlets (including those where accessories were attached). You may seal the inlets and outlets with blanking flanges or heavy gauge PVC tape.
6. Seal contaminated equipment in a thick polythene bag. If you do not have a polythene bag large enough to contain the equipment, you can use a thick polythene sheet.
7. If your equipment is a large pump (or any other large piece of equipment), strap the equipment and its accessories to a wooden pallet. Preferably, the pallet should be no larger than 510mm x 915mm (20" x 35"); contact your supplier if you cannot meet this requirement.
8. If your equipment is too small to be strapped to a pallet, pack it in a suitable strong box.
9. If the equipment is contaminated, label the pallet (or box) in accordance with laws covering the transport of dangerous substances.
10. Fax or post a copy of the Declaration (HS2) to your supplier. The Declaration must arrive before the equipment.
11. Give a copy of the Declaration to the carrier. You must tell the carrier if the equipment is contaminated.
12. Seal the original Declaration in a suitable envelope; attach the envelope securely to the outside of the equipment package. **WRITE YOUR RETURN AUTHORISATION NUMBER CLEARLY ON THE OUTSIDE OF THE ENVELOPE OR ON THE OUTSIDE OF THE EQUIPMENT PACKAGE.**

# Return of Edwards Equipment - Declaration (Form HS2)

Return Authorisation Number: \_\_\_\_\_

You must:

- Know about all of the substances which have been used and produced in the equipment before you complete this Declaration
- Read the Procedure (HS1) on the previous page before you attempt to complete this Declaration
- Contact your supplier to obtain a Return Authorisation Number and to obtain advice if you have any questions
- Send this form to your supplier before you return your equipment

## SECTION 1 : EQUIPMENT

Equipment model \_\_\_\_\_

Serial Number \_\_\_\_\_

Has the equipment been used, tested or operated?

yes  Go to Section 2                      no  Go to Section 4

FOR SEMICONDUCTOR APPLICATIONS ONLY :

Tool Reference Number \_\_\_\_\_

Process \_\_\_\_\_

Failure Date \_\_\_\_\_

Serial Number of Replacement Pump \_\_\_\_\_

## SECTION 2 : SUBSTANCES IN CONTACT WITH THE EQUIPMENT

Are any of the substances used or produced in the equipment

- Radioactive    yes     no
- Biologically active                                    yes     no
- Dangerous to human health and safety?    yes     no

If you have answered 'no' to all of these questions, go to Section 4.

Your supplier will not accept delivery of any equipment that is contaminated with radioactive substances, unless you:

- Decontaminate the equipment
- Provide proof of decontamination

**YOU MUST CONTACT YOUR SUPPLIER FOR ADVICE BEFORE YOU RETURN SUCH EQUIPMENT**

## SECTION 3 : LIST OF SUBSTANCES IN CONTACT WITH THE EQUIPMENT

Substance name	Chemical symbol	Precautions required (for example, use protective gloves, etc.)	Action required after spillage or human contact
1			
2			
3			
4			
5			
6			

## SECTION 4 : RETURN INFORMATION

Reason for return and symptoms of malfunction: \_\_\_\_\_  
\_\_\_\_\_

If you have a warranty claim:

- who did you buy the equipment from? \_\_\_\_\_
- give the supplier's invoice number \_\_\_\_\_

## SECTION 5 : DECLARATION

Print your name: \_\_\_\_\_ Print your job title: \_\_\_\_\_

Print your organisation: \_\_\_\_\_

Print your address: \_\_\_\_\_  
\_\_\_\_\_

Telephone number: \_\_\_\_\_ Date of equipment delivery: \_\_\_\_\_

I have made reasonable enquiry and I have supplied accurate information in this Declaration. I have not withheld any information. I have followed the Return of Edwards Equipment Procedure (HS1) on the previous page.

Signed: \_\_\_\_\_ Date: \_\_\_\_\_

# Edwards International

## EUROPE

### UNITED KINGDOM

Edwards High Vacuum International  
Manor Royal  
Crawley  
West Sussex RH10 2LW  
Tel: +44 (0) 1293 528844  
Fax: +44 (0) 1293 533453

### BELGIUM

Edwards  
Bergensesteenweg 709  
B1600 Sint-Pieters-Leeuw  
Tel: +32 (0) 2 363 0030  
Fax: +32 (0) 2 363 0064

### FRANCE

Edwards SA  
125 Avenue Louis Roche  
92238 Gennevilliers, Cedex  
Tel: +331 (1) 47 98 24 01  
Fax: +331 (1) 47 98 44 54

### GERMANY

Edwards Hochvakuum GmbH  
Postfach 1409  
D35004 Marburg  
Tel: +49 (0) 6420 82410  
Fax: +49 (0) 6420 824111

### ITALY

Edwards Alto Vuoto SpA  
Via Carpaccio 35  
20090 Trezzano Sul Naviglio  
Milano  
Tel: +39 (0) 2 4840 2258  
Fax: +39 (0) 2 4840 1638

### SWITZERLAND

Edwards (ECH)  
Postfach  
CH-4104 Oberwil-Basel  
Tel: +41 (0) 61 401 4344  
Fax: +41 (0) 61 401 4352

## AMERICAS

### USA

Edwards High Vacuum International  
One Edwards Park  
301 Ballardvale Street  
Wilmington, MA 01887-1075  
Tel: +1 (1) 508 658 5410  
Fax: +1 (1) 508 658 7969

Edwards High Vacuum International  
Sierra Technology Center  
Building 'A' Suite 120  
3100 Alvin Devane Boulevard  
Austin, TX 78741  
Tel: +1 (1) 512 389 3883  
Fax: +1 (1) 512 389 3890

Edwards High Vacuum International  
550 Sycamore Drive  
Milpitas, CA 95035  
Tel: +1 (1) 408 946 4707  
Fax: +1 (1) 408 946 8510

### CANADA

Edwards High Vacuum  
Tel: 800 387 4076  
Fax: +1 (1) 905 845 4924

### BRAZIL

Edwards Alto Vácuo  
Rua Bernardo Wrona, 222  
Bairro do Limão  
02710 - São Paulo - SP  
Tel: +55 (0) 11 8580377  
Fax: +55 (0) 11 2652766

## PACIFIC

### SINGAPORE

Edwards High Vacuum  
338 Swee Hong Industrial Building  
Circuit Road  
Singapore 1337  
Tel: +65 841 0615  
Fax: +65 841 0625

### JAPAN

Nippon Edwards KK  
Shuwa Shiba Park Bldg. A-3F  
2-4-1 Shibakoen  
Minato-ku  
Tokyo 105  
Tel: +81 (0) 3 5470 6530  
Fax: +81 (0) 3 5470 6521

Nippon Edwards KK  
Esaka Yodo Bldg. 5F  
16-34 Enoki-cho  
Suita-shi  
Osaka 564  
Tel: +81 (0) 6 384 7052  
Fax: +81 (0) 6 384 7504

Nippon Edwards KK  
508-1 Yomogi-machi  
Kumamoto-shi  
Kumamoto 861-55  
Tel: +81 (0) 96 326 7300  
Fax: +81 (0) 96 326 7302

### HONG KONG

Edwards High Vacuum (Pacific)  
1308 Tower II  
World Trade Square  
123 Hoi Bun Road  
Kwun Tong, Kowloon  
Hong Kong  
Tel: +852 2796 9111  
Fax: +852 2796 9095

### REPUBLIC OF KOREA

Songwon Edwards Ltd  
Sun In Building  
738-41 Panpo-Dong  
Sochu-Gu, Seoul  
Tel: +82 (0) 2 515 1811  
Fax: +82 (0) 2 515 1818