

PLASMA CLEANER

USER'S MANUAL FOR THE BASIC PLASMA CLEANER
(AND OPTIONAL PLASMAFLO)

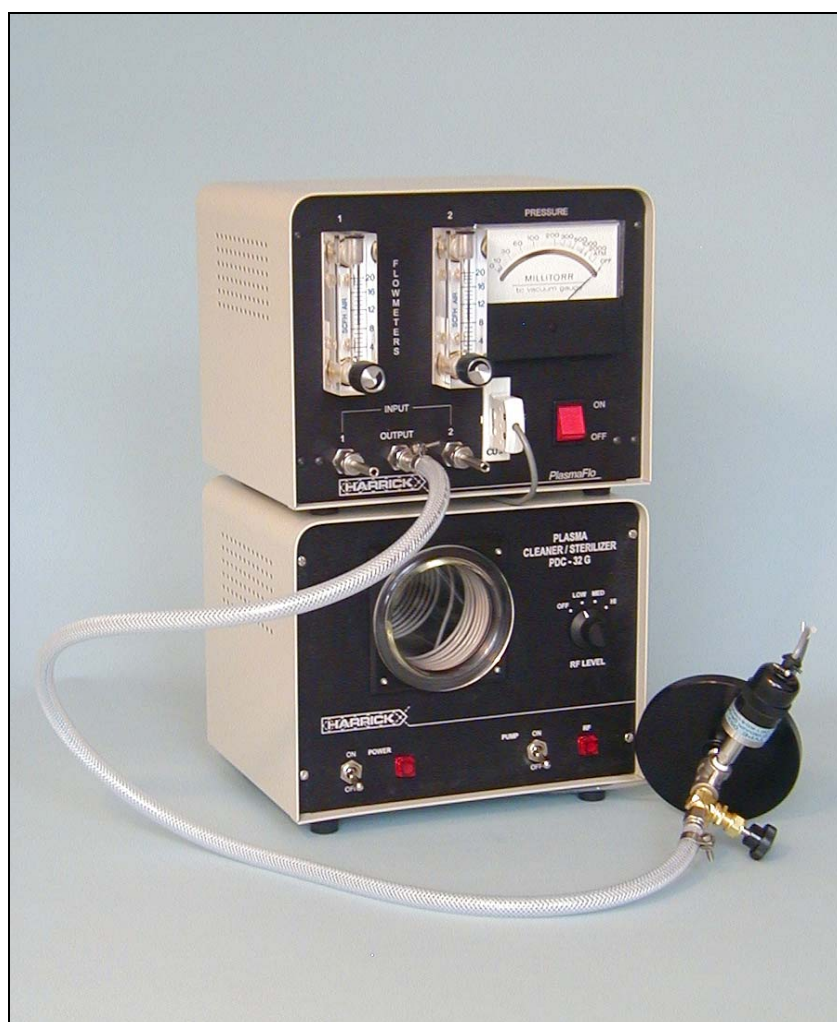



TABLE OF CONTENTS

General Information

Safety Information	1
Unpacking	1
Technical Support	1
Feedback	1

About the Plasma Cleaner

Principle of Operation	2
Getting Started	3

Processing with Room Air

Setup	4
Operation	4

Processing with Gas

Setup	6
Operation	7

Using the Optional PlasmaFlow

Getting Ready	9
Setup	10
Operation	11

Troubleshooting	13
------------------------------	----

Appendix A

Exchanging Needle Valves	14
--------------------------------	----

Appendix B

Replacing the Chamber	16
-----------------------------	----

Appendix C

Optional and Replacement Parts	17
--------------------------------------	----

Appendix D

Specifications	18
----------------------	----



GENERAL INFORMATION

SAFETY INFORMATION

The Plasma Cleaner is designed for safe and efficient operation when used properly and in accordance with this manual. Failure to observe the following precautions could result in serious personal injury:

- ⚠ The Plasma Cleaner is an electrical instrument. To avoid electric shock, please observe all standard precautions.
- ⚠ Do not use the Plasma Cleaner near flammable materials
- ⚠ In case of using oxygen gas for the processing gas, an oxygen compatible pump must be used.
- ⚠ In case of using toxic gases or gases that ionize to toxic products, like CF₄, an efficient exhaust filter must be used.
- ⚠ Do not plug vacuum pumps whose input electrical current requirement exceeds 7 amps into the Plasma Cleaner.
- ⚠ Do not open the Plasma Cleaner door when the chamber is under vacuum.

UNPACKING

Before installing the Plasma Cleaner make sure all the parts on the included check-off list are present. If any parts are missing or damaged, contact Harrick Scientific immediately.

TECHNICAL SUPPORT

For additional information please contact us at (USA) 800-640-6380 / (Intl) 607-272-5070 between 9 a.m. and 5 p.m. EST; or e-mail your questions to: info@harrickplasma.com.

FEEDBACK

Your comments and suggestions are welcome. Please send them to:

Harrick Plasma
120 Brindley St.
Ithaca, NY 14850
(USA) 800-640-6380
(Intl) 607-272-5070
(Fax) 607-272-5076
info@harrickplasma.com



ABOUT THE PLASMA CLEANER

PRINCIPLE OF OPERATION

When a gas under sufficiently low pressure is subjected to a high frequency oscillating electromagnetic field, the accelerated ions in the gas collide with the gas molecules ionizing them and forming plasma.

The ionized gas particles in the plasma interact with solid surfaces placed in the same environment by:

- **Removing organic contamination from surfaces.**
The high energy plasma particles combine with the contaminant to form carbon dioxide (CO₂) or methane (CH₄).
- **Modifying or enhancing the physical and chemical characteristics of surfaces.**
A chemical reaction occurs between the plasma gas molecules and the surface undergoing treatment.

The operation of the Plasma Cleaner is simple. The sample is placed in the reaction chamber. Low flow rates (typically 5-10 SCFH) of process gas at low pressure (typically 200-600 mtorr) are subjected to RF (radio frequency) electromagnetic radiation at 8-12 MHz creating plasma, at near ambient temperatures, within the chamber.

The type of interaction between the plasma and the surface depends on parameters such as the intensity and frequency of the RF power used to excite the plasma, the type of gas(es) that are ionized, the pressure and flow rate of the gas(es), the type of sample and the amount of time the surface is exposed to the plasma.

ABOUT THE PLASMA CLEANER

GETTING STARTED

Before starting, take a few moments to familiarize yourself with the Plasma Cleaner by looking at the drawings of the front and back of the unit (Figures 1, 2).

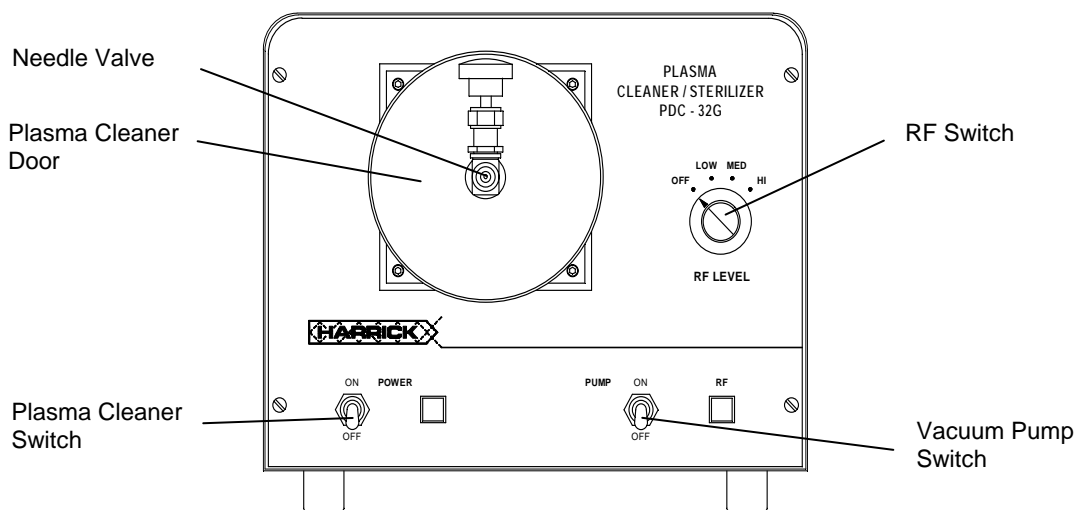

Figure 1 • Plasma Cleaner Front View (110V Model)

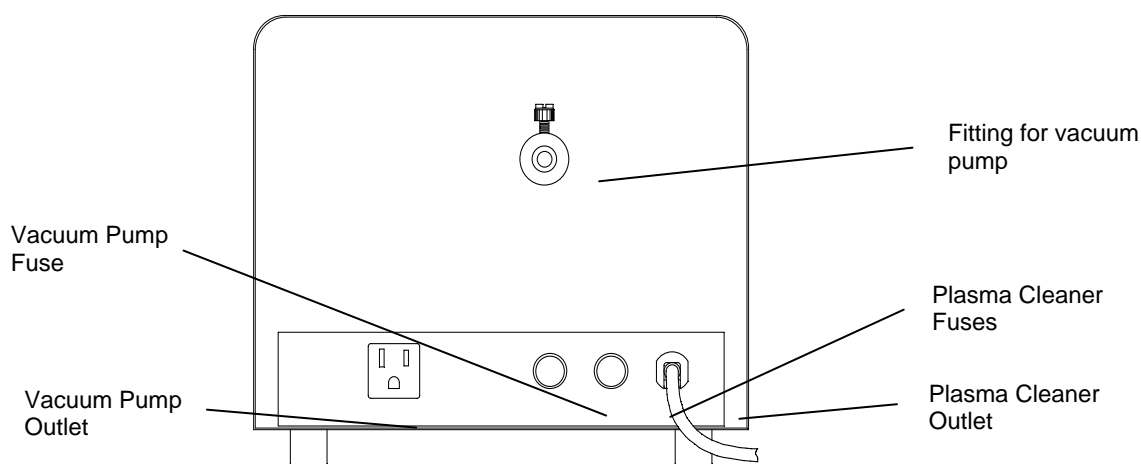

Figure 2 • Plasma Cleaner Back View (110V Model)

PROCESSING WITH ROOM AIR

SETUP

To setup the Plasma Cleaner for processing with room air (Figure 3):

- Connect the fitting at the rear of the Plasma Cleaner (Figure 2) to the vacuum pump with $\frac{1}{2}$ " ID vacuum tubing.
- Tighten hose clamps over the tubing at each end.
- Plug the Plasma Cleaner in a grounded outlet.
- Plug the vacuum pump into the vacuum pump outlet on the back of the Plasma Cleaner (110V model, Figure 2) or into another outlet (220V model).



CAUTION:

The Plasma Cleaner is designed for vacuum pumps requiring up to 7 amps.

DO NOT plug a vacuum pump whose input electrical current requirement exceeds 7 amps into the plasma cleaner pump outlet.

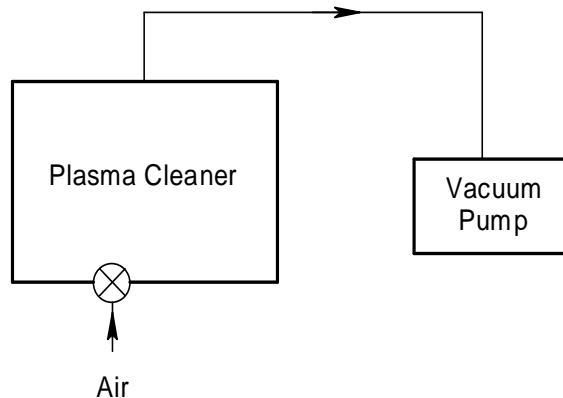

Figure 3 • Diagram for Room Air Processing

OPERATION

EVACUATING THE CHAMBER

- Put the sample in the Plasma Cleaner chamber.
- Hold the Plasma Cleaner door against the vacuum chamber.
- Turn on the vacuum pump switch on the front of the Plasma Cleaner (110V model, Figure 1) or on the vacuum pump (220V model). It will take a few minutes to evacuate the air in the Plasma Cleaner chamber. The vacuum will hold the Plasma Cleaner door in place.

PROCESSING WITH ROOM AIR

BLEEDING IN AIR

- To bleed room air into the chamber, slightly open the needle valve and allow the air to enter the Plasma Cleaner chamber.
- Close the needle valve.

GENERATING PLASMA

- Turn on the Plasma Cleaner switch on the front of the Plasma Cleaner (Figure 1).
- Select the appropriate RF level.
- Look down at an angle through the holes in the top of the Plasma Cleaner and wait until a purplish glow is observed. This indicates that plasma has been generated.

NOTE: *The RF power level used should be set at the lowest level, needed to initiate a glow discharge.*

PROCESSING

- Subject the sample to plasma for a few minutes.
- Upon completion of cleaning set the RF level to OFF.
- Turn off the Plasma Cleaner.

VENTING THE CHAMBER

- Turn off the vacuum pump.
- Hold the door and slowly open the needle valve to allow air to enter the chamber.
- Vent the chamber until atmospheric pressure is reached and remove the door.
- Close the needle valve.
- Take out the sample.



CAUTION:

If the reaction chamber is not vented immediately, oil may back stream from the vacuum pump and contaminate the system. We recommend the use of vacuum pump with an anti suck back feature, such as that optionally provided by Harrick Scientific Corporation. Do not open the door when the chamber is under vacuum since this will damage the glass chamber.

SETUP

To setup the Plasma Cleaner for processing with process gas, refer to the diagram below (Figure 4) and follow these steps:

- Connect the fitting at the rear of the Plasma Cleaner (Figure 2) to a vacuum pump with ½" ID vacuum tubing and hose clamps over the tubing at each end.
- Connect the needle valve on the Plasma Cleaner door (Figure 1) to the gas source through a pressure regulator.
- Plug the Plasma Cleaner in a grounded outlet.
- Plug the vacuum pump into the vacuum pump outlet on the back of the Plasma Cleaner (Figure 2) or into a second outlet.



CAUTION:

The Plasma Cleaner is designed for vacuum pumps requiring up to 7 amps.

DO NOT plug a vacuum pump whose input electrical current requirement exceeds 7 amps into the plasma cleaner pump outlet.

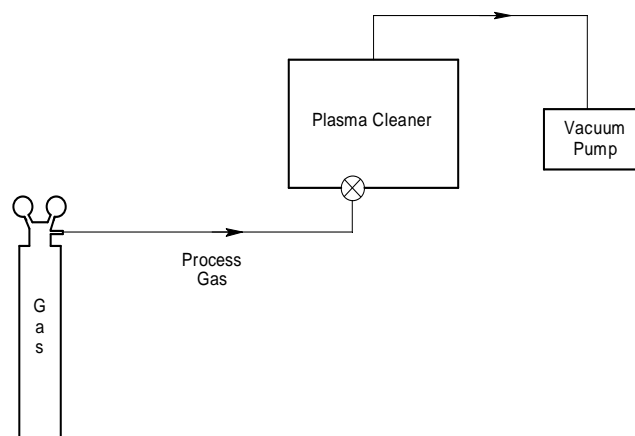

Figure 4 • Diagram for Processing with Gas

NOTE: *To be able to monitor and control the pressure and rate of flow of the process gas, we recommend connecting the optional PlasmaFlo (Figure 6).*



CAUTION:

For processing with pure oxygen, make sure that you use an oxygen compatible vacuum pump. The optional Harrick Scientific Vacuum pumps are NOT oxygen compatible. The hydrocarbon pump oil mist can react with the ozone formed producing a potentially explosive combination.

PROCESSING WITH GAS

OPERATION

PURGING THE GAS LINE/S

Purging of the gas line with the process gas is recommended if there is a possibility that the gas line contains unwanted substances.

- Open the gas flow.
- Set the process gas regulator to 10 psi.
- Open the needle valve.
- With the Plasma Cleaner door off, purge the gas line for a few minutes to flush out contaminants.
- Close the needle valve.

EVACUATING THE CHAMBER

- Put the sample in the Plasma Cleaner chamber.
- Hold the Plasma Cleaner door against the vacuum chamber.
- Turn on the vacuum pump switch on the front of the Plasma Cleaner (Figure 1). It will take a few minutes to evacuate the air from the reaction chamber of the Plasma Cleaner. The vacuum will hold the Plasma Cleaner door in place.

BLEEDING IN PROCESS GAS

- To bleed process gas into the chamber, slowly open the needle valve and allow the gas to flow for a few minutes.

GENERATING PLASMA

- Close the needle valve.
- Turn on the Plasma Cleaner switch on the front of the Plasma Cleaner (Figure 1).
- Select the appropriate RF level.
- Wait until a purplish glow is observed. This indicates that plasma has been generated.

NOTE: *The RF power level used should be set at the lowest level, just enough to initiate a glow discharge. Gas pressures in the vicinity of ~ 600 mtorr and low to medium RF level are a reasonable starting point, but develop a set of conditions which work best for the type of samples you most often use.*

PROCESSING WITH GAS

PLASMA PROCESSING

- Carefully open the needle valve just enough to bleed process gas into the reaction chamber without extinguishing the plasma.

NOTE: *If the plasma disappears when bleeding in process gas, the needle valve should be closed to allow plasma to form and then opened very slightly making sure not to lose the purplish glow.*

- Subject the sample to plasma processing for the desired duration.
- Upon completion of processing turn the RF level to OFF.
- Turn off the Plasma Cleaner.

NOTE: *By selection of the process gas (or mixture of gases), its plasma energy (RF power), and the processing duration, the nature and extent of the surface interactions can be tailored to your application.*

VENTING THE CHAMBER

- Turn off the vacuum.
- Hold the door and vent the chamber for a few minutes.
- When atmospheric pressure is reached remove the door.
- Close the needle valve.
- Take out the sample.



CAUTION:

If the Plasma Cleaner chamber is not vented immediately, oil may back stream from the vacuum pump and contaminate the system. We recommend the use of vacuum pump with an anti suck back feature, such as that optionally provided by Harrick Scientific Corporation. Do not open the door when the chamber is under vacuum since this will damage the glass chamber.

USING THE OPTIONAL PLASMAFLO

GETTING READY

Before starting take a few moments to familiarize yourself with the PlasmaFlo by looking at the drawings of the front and back views (Figures 5, 6).

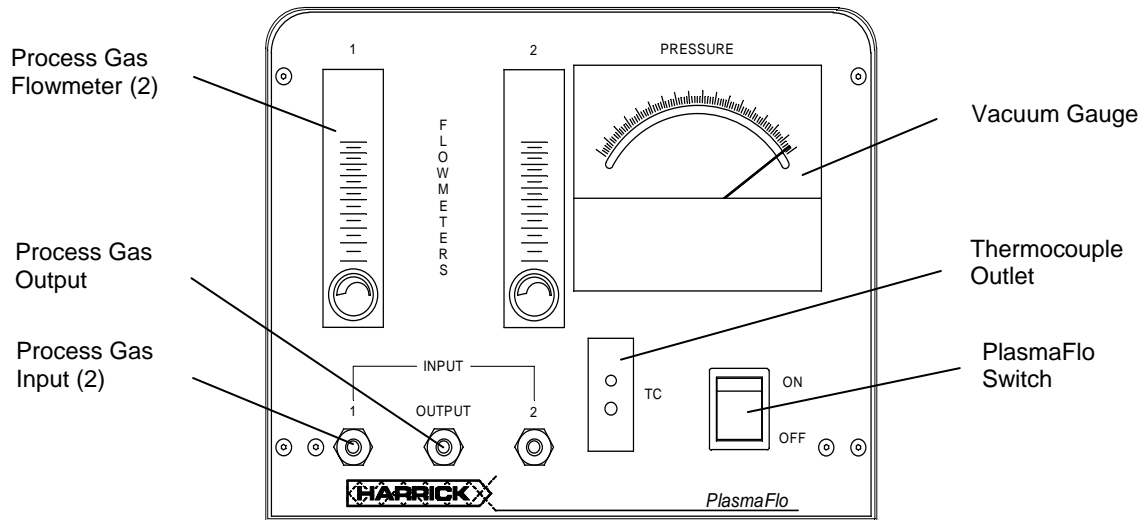

Figure 5 • The PlasmaFlo Front View

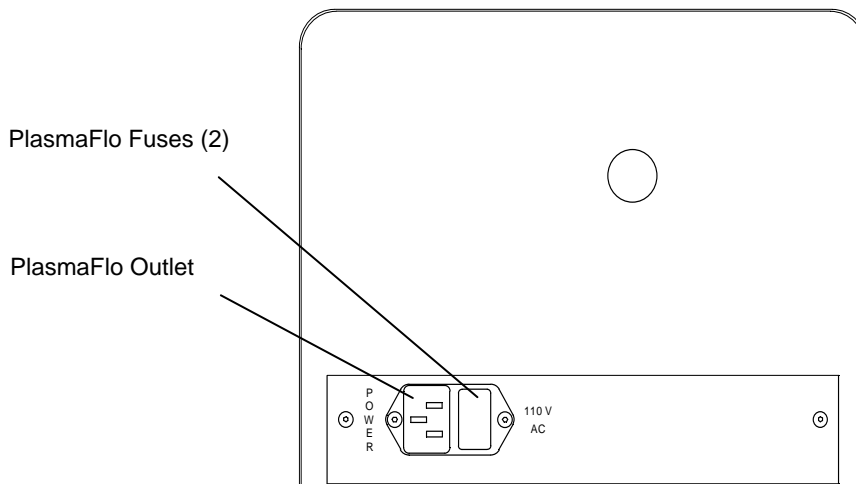

Figure 6 • The PlasmaFlo Back View

USING THE OPTIONAL PLASMAFLO

SETUP

To setup the Plasma Cleaner for cleaning with gases using the optional PlasmaFlo (Figures 5, 6), refer to the diagram below (Figure 7) and follow these steps:

- Connect the fitting at the rear of the Plasma Cleaner (Figure 2) to the vacuum pump with ½" ID vacuum tubing and hose clamps over the tubing at each end.
- Connect the needle valve on the Plasma Cleaner door to the output on the front of the PlasmaFlo.
- Plug the thermocouple gauge attached to the Plasma Cleaner door into the thermocouple outlet on the front of the PlasmaFlo.

NOTE: *If the PlasmaFlo was purchased separately from the Plasma Cleaner, the regular needle valve needs to be replaced with the needle valve with the attached thermocouple gauge (See Appendix A).*

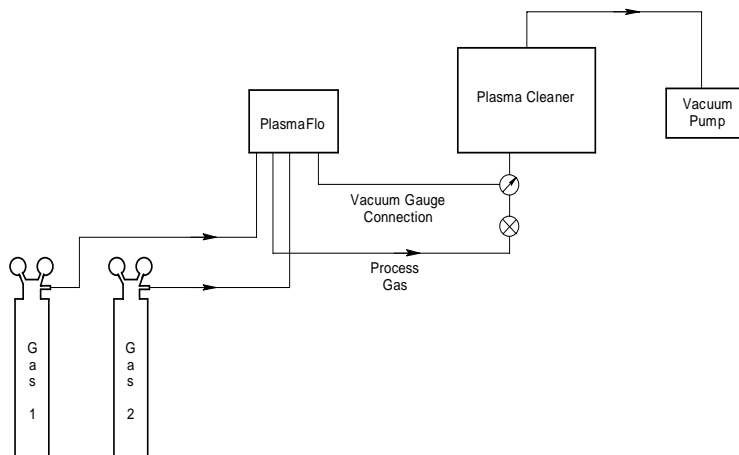

Figure 7 • Diagram for Processing Using the PlasmaFlo

USING THE OPTIONAL PLASMAFLO

- Connect the gas source/s to the input/s on the front of the PlasmaFlo.
- Plug the Plasma Cleaner and the PlasmaFlo into grounded outlets.
- Plug the vacuum pump into the vacuum pump outlet on the back of the Plasma Cleaner.



CAUTION:

The Plasma Cleaner is designed for vacuum pumps requiring up to 7 amps.

DO NOT plug a vacuum pump whose input electrical current requirement exceeds 7 amps into the plasma cleaner pump outlet.

OPERATION

PURGING THE GAS LINE/S

Purging of the gas line with the process gas is recommended if there is a possibility that the gas line contains unwanted substances.

- Open the gas flow.
- Set the process gas regulator to 10 psi.
- Open the needle valve.
- With the Plasma Cleaner door off, purge the gas line a few minutes to flush out any contaminants.
- Close the needle valve.

EVACUATING THE CHAMBER

- Put the sample in the Plasma Cleaner chamber.
- Hold the Plasma Cleaner door against the vacuum chamber.
- Turn on the PlasmaFlo switch on the front of the PlasmaFlo.
- Turn on the vacuum pump switch on the front of the Plasma Cleaner (Figure 1). It will take a few minutes to evacuate the air from the reaction chamber of the Plasma Cleaner. The vacuum will hold the Plasma Cleaner door in place. Monitor the pressure on the vacuum gauge on the PlasmaFlo.

USING THE OPTIONAL PLASMAFLO

BLEEDING IN PROCESS GAS/S

- To bleed process gas/s into the chamber, slowly open the needle valve. Adjust the amount of gas/s using the flowmeter control knobs on the PlasmaFlo.

GENERATING PLASMA

- Turn on the Plasma Cleaner switch on the front of the Plasma Cleaner (Figure 1).
- Select the appropriate RF level. Wait until a purplish glow is observed. This indicates that plasma has been generated.

NOTE: *The RF power level used should be set at the lowest level, just enough to initiate a glow discharge. Gas pressures in the vicinity of ~ 600 mtorr and low to medium RF level are a reasonable starting point, but develop a set of conditions which work best for the type of samples you most often use.*

PLASMA PROCESSING

- Subject the sample to plasma processing for a few minutes.
- Upon completion of processing set the RF level to OFF.
- Turn off the Plasma Cleaner.

NOTE: *By selecting the process gas (or gas mixture) and plasma energy (RF power), the nature and extent of the surface interactions can be tailored for your application.*

VENTING THE CHAMBER

- Turn off the vacuum.
- Hold the door and vent the chamber for a few minutes.
- When atmospheric pressure is reached remove the door.
- Close the needle valve.
- Remove the sample.



CAUTION:

If the Plasma Cleaner chamber is not vented immediately, oil may back stream from the vacuum pump and contaminate the system. . We recommend the use of vacuum pump with an anti suck back feature, such as that optionally provided by Harrick Scientific Corporation. Do not open the door when the chamber is under vacuum since this will damage the glass chamber.

TROUBLESHOOTING

MALFUNCTION	POSSIBLE CAUSES	CORRECTIVE ACTIONS
<p>plasma fails to form in the chamber</p>	<p>the electronics fails to deliver power to RF coil</p> <p>the vacuum system fails to sufficiently evacuate the chamber.</p>	<p>Place the miniature fluorescent bulb supplied with the Plasma Cleaner into the chamber. Leave the door open and turn the RF level to HIGH. If the bulb glows, the electronic system is functioning properly. If it does not, check the fuses at the back of the unit. Replace any that are defective and repeat the test with the fluorescent bulb. If this test still fails, contact Harrick Scientific Corporation.</p> <p>If you are using a vacuum pump not supplied by Harrick Scientific Corp., make sure that your vacuum pump is capable of reaching a pressure of 200 mtorr or less. Then check that the vacuum hose is properly attached, the Plasma Cleaner door is properly seated, the o-rings are in place, and that the window is intact. All o-rings should be clean and free of defects.</p>

**EXCHANGING
NEEDLE VALVES**

To replace the standard needle valve with the needle valve with the attached thermocouple gauge:

- Using a 9/16" end wrench or an adjustable wrench, unscrew the regular needle valve(Figure 8).

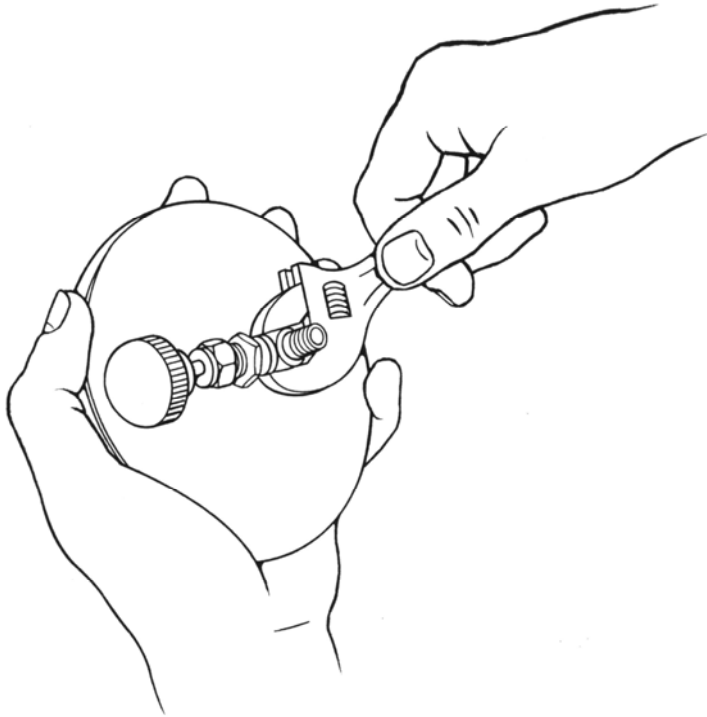

Figure 8 • Removing the Standard Needle Valve

APPENDIX A

- Replace it with the needle valve with the attached thermocouple (Figure 9).
- Tighten the needle valve with a $7/16$ " end wrench or an adjustable wrench.

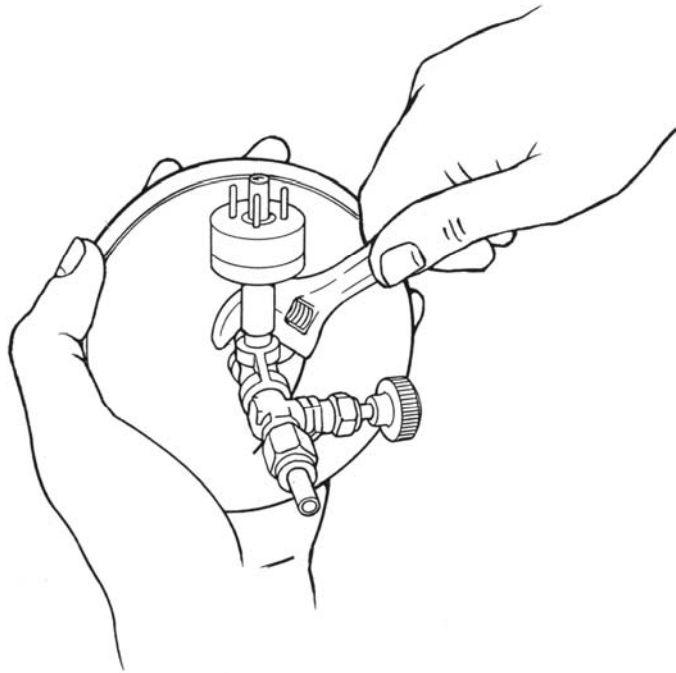

Figure 9 • Installing the Needle Valve with the Thermocouple Gauge

REPLACING THE CHAMBER

To replace the Plasma Cleaner chamber:

- Disconnect the tubing to the chamber.
- Loosen the thumbscrew on the fitting for the vacuum pump on the back of the Plasma Cleaner (Figure 2).
- Pull out the glass chamber.
- Slide in the new chamber.
- Tighten the thumbscrew on the back of the Plasma Cleaner.
- Reconnect the tubing to the chamber.



APPENDIX C

OPTIONAL AND REPLACEMENT PARTS

OPTIONAL PARTS

Vacuum Pump, 110V	PDC-VP
Vacuum Pump, 220V	PDC-VP-2
Vacuum Pump Oil	PDC-VP-OIL
Vacuum Pump Economy, 110V	PDC-VPE
Vacuum Pump Economy, 220V	PDC-VPE-2
Vacuum Pump Economy Oil	PDC-VPE-OIL
PlasmaFlo, 110V	PDC-FMG-1
PlasmaFlo, 220V	PDC-FMG-2
Quartz Plasma Chamber	PDC-32Q
Quartz Sample Tray	PDC-32T

REPLACEMENT PARTS

Pyrex Vacuum Chamber	PDC-191-105
Chamber O-ring, Viton	ORV-341
Fluorescent Bulb	PDC-FLB

REPLACEMENT FUSES

	110V (PDC-32G)	220V (PDC-32G-2)
Plasma Cleaner	3 amp, fast acting	3 amp, fast acting
Vacuum Pump	7 amp, fast acting	None
PlasmaFlo	0.5 amp, fast acting	0.5 amp, fast acting



APPENDIX D

SPECIFICATIONS

PLASMA CLEANER

Chamber Dimensions	3" diameter by 7" deep
System Dimensions	8" H x 10" W x 8" D
System Weight	12 lbs
Chamber Material	Pyrex
Input Power	100 W
RF Frequency	8 -12 MHz
Inlet	1/8" NPT needle valve
Outlet	1/2" O.D. glass or quartz tubing

POWER APPLIED TO RF COIL

Low Setting	6.8 W
Medium Setting	10.5 W
High Setting	18 W

UTILITIES REQUIRED

Vacuum Pump	minimum pumping speed of 1.4 m ³ h ⁻¹ and an ultimate total pressure of 200 mtorr or less
-------------------	---

OPTIONAL VACUUM PUMPS

Models PDC-VP and PDC-VP-2

Pumping speed 50/60 Hz	3,2/3,6 m ³ h ⁻¹
Ultimate total pressure	23 mtorr
Motor power	250/300 W
Weight	33 lbs
Dimensions	9" H x 15" W x 5" D

Models PDC-VPE-1 and PDC-VPE-2

Pumping speed 50/60 Hz	10.2 m ³ h ⁻¹
Ultimate total pressure	20 mtorr
Motor power	325 W
Weight	27 lbs
Dimensions	9 3/4" H x 15" W x 5 5/8" D



Manual Part No. PDC32G-M-03