

A comprehensive portfolio of flexible service, field kits/upgrades, machine and subassembly rebuilds, spare parts, training and other support programs provides added value for K&S equipment. Customers receive optimal machine uptime, reduced maintenance and spare parts costs, extended machine life, and automatic upgrades to the latest revisions.

K&S maintains a North American Customer Response Center and a worldwide customer support organization that offers:



- Field service personnel factory trained in 15 countries
- Technical support in Europe, North America, Asia and Japan
- Technical training on all active K&S products
- Complete user documentation (operations, maintenance, reference material)
- Process development and applications support at K&S technology centers
- Individually tailored preventive maintenance and guaranteed response programs
- A worldwide network of spare and replacement parts depots
- ➔ Automated access to parts inventories and order processing
- Factory rebuild and exchange services for machines, critical sub-assemblies and parts

Our new **Technical Training Bulletin Board Service** provides online access to a wealth of training information such as course descriptions, training schedules and pricing. For information, dial up the BBS at 1-800-222-5542.

**Need Immediate Assistance?** Call for Telephone Technical Support, 8:00 a.m. - 8:00 p.m. Eastern Standard Time, 1-800-422-5542.



[Home](#) | [Mail](#)

3/19/98

**Kulicke and Soffa Industries, Inc.**

# **MODEL 4123**

## **WEDGE BONDER**

### **OPERATION AND MAINTENANCE MANUAL**

Copyright 1992 by Kulicke and Soffa Industries, Incorporated.  
All rights reserved. Reproductions or copying of this publication, by any means, is prohibited without the written permission of Kulicke and Soffa Industries, Inc.

## ABOUT THIS MANUAL

This manual is for use by both the K&S Model 4123 Wedge Bonder operator and maintenance technician. For this reason it is divided into two sections:

### Section One - Operation

Section One contains the operating instructions for the 4123 Wedge Bonder.

Included in this section are installation instructions, theory of operation, descriptions of the controls and indicators, setup and adjustments.

### Section Two - Maintenance

Section Two contains information and instructions to guide the maintenance technician in maintaining the 4123 Wedge Bonder in top running condition.

Included in this section are complete mechanical and electrical descriptions of the Wedge Bonder including disassembly and assembly instructions for major subassemblies, also instructions on how to make mechanical adjustments, perform diagnostics and preventive maintenance, as well as troubleshooting the machine.

## LIST OF EFFECTIVE PAGES

This manual consists of 200 pages, as follows:

Introduction		i - xvii	Rev 0
Chapter 1	pages	1-1 - 1-12	Rev 0
Chapter 2	pages	2-1 - 2-10	Rev 0
Chapter 3	pages	3-1 - 3- 9	Rev 0
Chapter 4	pages	4-1 - 4-23	Rev 0
Chapter 5	pages	5-1 - 5- 1	Rev 0
Chapter 6	pages	6-1 - 6- 4	Rev 0
Chapter 7	pages	7-1 - 7- 2	Rev 0
Chapter 8	pages	8-1 - 8-27	Rev 0
Chapter 9	pages	9-1 - 9-45	Rev 0
Chapter 10	pages	10-1 - 10- 2	Rev 0
Chapter 11	pages	11-1 - 11- 2	Rev 0
Chapter 12	pages	12-1 - 12-12	Rev 0
Chapter 13	pages	13-1 - 13-14	Rev 0
Chapter 14	pages	14-1 - 14- 3	Rev 0
Chapter 15	pages	15-1 - 15-19	Rev 0

TABLE OF CONTENTS

INTRODUCTION . . . . . xii

SPECIFICATIONS . . . . . xv

SECTION ONE  
OPERATION

INSTALLATION . . . . . 1 - 1

UNPACKING AND INSTALLATION . . . . . 1 - 1

OPTIONAL ITEM INSTALLATION . . . . . 1 - 9

    Spotlight Installation . . . . . 1 - 9

    B&L Microscope Holder/Microscope Installation . . . . . 1 - 11

    WILD M3Z Microscope Installation . . . . . 1 - 12

PHYSICAL DESCRIPTION . . . . . 2 - 1

THE MAIN HEAD . . . . . 2 - 3

    Stereo Zoom Microscope . . . . . 2 - 4

    The Bonding Head . . . . . 2 - 4

    Wire Tear and Tail Control System . . . . . 2 - 6

    Tool Lifter . . . . . 2 - 7

    Clamp Lifter . . . . . 2 - 7

    The Area Light . . . . . 2 - 7

    The Spotlight (Optional) . . . . . 2 - 7

THE BASE . . . . . 2 - 9

    The Manipulator and Chessman . . . . . 2 - 9

    The Right and Left Control Panels . . . . . 2 - 10

---

**TABLE OF CONTENTS**

<b>CONTROLS AND INDICATORS</b> . . . . .	3 - 1
THE LEFT CONTROL PANEL . . . . .	3 - 1
THE RIGHT CONTROL PANEL . . . . .	3 - 5
Indicators . . . . .	3 - 5
Dials . . . . .	3 - 5
Z Lever Option . . . . .	3 - 8
CHESSMAN . . . . .	3 - 9
<b>SETUP AND ADJUSTMENTS</b> . . . . .	4 - 1
WEDGE INSTALLATION . . . . .	4 - 2
MICROSCOPE ADJUSTMENT . . . . .	4 - 5
WORKHOLDER INSTALLATION AND HEIGHT ADJUSTMENT . . . . .	4 - 7
SETTING WORKHOLDER TEMPERATURE . . . . .	4 - 9
WIRE LOADING . . . . .	4 - 10
Wire Loading - 0.5" Spool . . . . .	4 - 10
Wire Loading - 2" Spool . . . . .	4 - 11
Useful Tips for Wire Threading . . . . .	4 - 13
BONDING PARAMETERS . . . . .	4 - 14
Power . . . . .	4 - 14
Time . . . . .	4 - 14
Force . . . . .	4 - 14
Setting and Measuring the Bonding Force . . . . .	4 - 15
SETTING SEARCH POSITION . . . . .	4 - 17

TABLE OF CONTENTS

TAIL LENGTH AND TEAR ADJUSTMENTS . . . . .	4 - 18
Tail Length Adjustment . . . . .	4 - 18
Tear Point Adjustment . . . . .	4 - 19
OPTIMAL BONDING SETTINGS . . . . .	4 - 20
Bond Strength Optimization . . . . .	4 - 21
SPOTLIGHT ADJUSTMENT . . . . .	4 - 23
Coarse Adjustment . . . . .	4 - 23
Focusing . . . . .	4 - 23
Fine Adjustment . . . . .	4 - 23
BONDING TIME SETUP . . . . .	5 - 1
BONDING OPERATION . . . . .	6 - 1
Chessman Mode Bonding Cycle . . . . .	6 - 1
Manual Z Bonding . . . . .	6 - 4
Stitch Bonding . . . . .	6 - 4

---

**TABLE OF CONTENTS**
**SECTION TWO  
MAINTENANCE**

<b>MAINTENANCE INTRODUCTION</b> . . . . .	7 - 1
General Guidelines . . . . .	7 - 1
Machine Adjustments Checklist . . . . .	7 - 2
<b>ELECTRICAL SUBASSEMBLIES</b> . . . . .	8 - 1
<b>4123 ELECTRICAL DESCRIPTION</b> . . . . .	8 - 4
The Power Supply . . . . .	8 - 4
The Mother Board . . . . .	8 - 5
Connector J1 . . . . .	8 - 6
Connector J2 . . . . .	8 - 6
Connector J3 . . . . .	8 - 6
Connector J4 . . . . .	8 - 6
Connector J5 . . . . .	8 - 6
Fuses . . . . .	8 - 6
The Logic Board . . . . .	8 - 7
The Logic Board Power Supply . . . . .	8 - 7
Fuse F1 . . . . .	8 - 7
The Logic Unit . . . . .	8 - 9
Sinewave Generator . . . . .	8 - 9
Z Motor Mode . . . . .	8 - 9
The Ultrasonic Generator Circuit . . . . .	8 - 9
The Force Circuit . . . . .	8 - 10
Clamp and Tail Solenoid Circuits . . . . .	8 - 10
Connectors . . . . .	8 - 11
Logic Board Machine Adjustment Points . . . . .	8 - 14
Logic Board Test Points . . . . .	8 - 16
Jumper Configuration . . . . .	8 - 17



## TABLE OF CONTENTS

External Ultrasonic Generator Connector . . . . .	8 - 18
BASE BACK COVER . . . . .	8 - 19
TEMPERATURE CONTROLLER - KTC . . . . .	8 - 20
Power Supply . . . . .	8 - 20
Load Driver . . . . .	8 - 20
ELECTRICAL ASSEMBLIES REPLACEMENT AND ADJUSTMENT . . . . .	8 - 22
Logic Board Replacement . . . . .	8 - 22
Adjusting the 18Vptp . . . . .	8 - 23
Ultrasonic Generator Adjustment . . . . .	8 - 24
Ultrasonic Free Running Frequency Adjustment . . . . .	8 - 24
Ultrasonic Power Adjustment . . . . .	8 - 25
Z Motor Speed Adjustment . . . . .	8 - 27
MECHANICAL SUBASSEMBLIES . . . . .	9 - 1
MAIN HEAD ASSEMBLY . . . . .	9 - 1
Bonding Head Drive Mechanism . . . . .	9 - 4
The Force Actuator . . . . .	9 - 4
The Air Dashpot . . . . .	9 - 5
Height Control Link and Contact Mechanism . . . . .	9 - 6
Z Motor . . . . .	9 - 7
Tool Lifter . . . . .	9 - 7
Clamp Lifter . . . . .	9 - 7
BONDING HEAD MAINTENANCE . . . . .	9 - 8
Bonding Head Motion . . . . .	9 - 8
Replacing the Flange Bearings . . . . .	9 - 9
Bonding Head Bearings Adjustment . . . . .	9 - 11
Adjusting Static Bonding Force and Dashpot . . . . .	9 - 12
Replacement of Dashpot . . . . .	9 - 13
FORCE ACTUATOR ASSEMBLY . . . . .	9 - 14
Force Actuator Checkout . . . . .	9 - 14
Force Actuator Disassembly . . . . .	9 - 14
Force Actuator Replacement . . . . .	9 - 15
Adjusting the Force Actuator Assembly . . . . .	9 - 16

---

**TABLE OF CONTENTS**

MAIN LVDT RESET POSITION ADJUSTMENT . . . . .	9 - 17
TRANSDUCER REPLACEMENT AND LEVELING . . . . .	9 - 19
CLAMP SOLENOID, WIRE CLAMP REPLACEMENT AND ADJUSTMENT . . . . .	9 - 24
Clamp Solenoid Replacement . . . . .	9 - 25
Clamp Solenoid Gap Adjustment . . . . .	9 - 26
Clamp Lateral Position Adjustment . . . . .	9 - 28
Wire Tension Adjustment - 0.5" Spool Holder . . . . .	9 - 30
THE TEAR AND FEED BRACKET . . . . .	9 - 31
Tear Solenoid/Tail Solenoid Replacement . . . . .	9 - 32
The Manipulator Assembly . . . . .	9 - 33
The Chessman Handle . . . . .	9 - 35
Chessman Assembly Removal . . . . .	9 - 36
Chessman Disassembly . . . . .	9 - 37
Replacing CHESSMAN Pushbutton . . . . .	9 - 37
Disassembling the Manipulator . . . . .	9 - 38
AREA ILLUMINATION LAMP . . . . .	9 - 39
THE SPOTLIGHT . . . . .	9 - 39
Light Source . . . . .	9 - 39
Tube . . . . .	9 - 39
Cone . . . . .	9 - 39
Spotlight Lamp Replacement . . . . .	9 - 40
THE MANUAL Z ASSEMBLY . . . . .	9 - 41
The Z Lever . . . . .	9 - 41
The Z Photozell . . . . .	9 - 41
The Z LVDT . . . . .	9 - 41
Manual Z Photozell Flag Adjustment . . . . .	9 - 43
Manual Z Engaging Pin Gap Adjustment . . . . .	9 - 43
Manual Z LVDT Adjustment . . . . .	9 - 44
Manual Z Overtravel Position Adjustment . . . . .	9 - 45

TABLE OF CONTENTS

TIMING DIAGRAM . . . . .	10 - 1
Timing Diagram Explanation . . . . .	10 - 2
DIAGNOSTICS . . . . .	11 - 1
PREVENTIVE MAINTENANCE . . . . .	12 - 1
Clean the Bonding Head Contact Pin and Screw . . . . .	12 - 2
Clean Wire Clamps . . . . .	12 - 3
Check Force Actuator Coil Motion . . . . .	12 - 4
Check Z Motor Drive Belt Tension . . . . .	12 - 5
Check Bonding Head Movement and Dashpot . . . . .	12 - 6
Clean Manipulator and Base . . . . .	12 - 7
Check Cam Follower Bearing . . . . .	12 - 8
Check Height Control Link Motion . . . . .	12 - 9
Adjust LVDT Oscillator Voltage . . . . .	12 - 10
Adjust Ultrasonic Generator . . . . .	12 - 10
Adjust Temperature Controller Zero Offset . . . . .	12 - 11
Clean Tear and Tail Solenoids . . . . .	12 - 12
TRUBLESHOOTING . . . . .	13 - 1
GENERAL . . . . .	13 - 2
BONDING PROCESS . . . . .	13 - 7
OPTIONS AND ACCESSORIES . . . . .	14 - 1
Optical Accessories . . . . .	14 - 1
Cold Workholders . . . . .	14 - 2
Height-Adjustable Heated Workholders . . . . .	14 - 2
Spare Parts and Maintenance Kits . . . . .	14 - 3
Power Supplies . . . . .	14 - 3
Miscellaneous . . . . .	14 - 3

## ERRATA

Whenever Head Body part no. 04124-0410-000 appears in this book, please read it as Head Body part no. 04123-0410-000. (Replacing 04124 by 04123).

## TABLE OF CONTENTS

SPARE PARTS LIST . . . . .	15 - 1
Base Frame 04123-0211-000 . . . . .	15 - 2
Front Panel Assy 04123-0213-000 . . . . .	15 - 3
Lever Assy 04123-0214-000 . . . . .	15 - 4
X-Y Frame 04123-0215-000 . . . . .	15 - 4
Chessman 04123-0420-000 . . . . .	15 - 5
Main Head Assy 04123-0405-000 . . . . .	15 - 6
Tool Lifter 04123-0412-000. . . . .	15 - 7
LVDT Assy 04123-0414-000. . . . .	15 - 7
Clamp Lifter 04123-0416-000 . . . . .	15 - 8
Force Actuator Assy 04123-0417-000 . . . . .	15 - 8
Tear and Feed System 04123-0422-000 . . . . .	15 - 8
Spool Support 1/2" 04123-0426-000 . . . . .	15 - 9
Bonding Head 04123-0450-000 . . . . .	15 - 10
Bracket Assy for Tear and Feed Solenoid 04123-0452-000 . . . . .	15 - 11
Height Control Link 04123-0455-000 . . . . .	15 - 12
Coil and Actuator Assy 04123-1920-000 . . . . .	15 - 12
Mother Board 04123-4320-000 . . . . .	15 - 13
Manual Z (Optional) 04123-7200-000 . . . . .	15 - 13
Manual Z Kit 04123-7210-000 . . . . .	15 - 14
Spotlight Assy 04123-7300-000 . . . . .	15 - 15
Manipulator 04124-0212-000 . . . . .	15 - 16
Head Body 04124-0410-000 . . . . .	15 - 17
Harness, Chessman 04123-1401-000 . . . . .	15 - 18
Microscope Holder 04123-0350-000 . . . . .	15 - 18
Maintenance Tool Kit 04123-0910-000 . . . . .	15 - 19

LIST OF FIGURES

Figure 1-1	Wedge Bonder Packaging - Exploded View . . . . .	1	-	2
Figure 1-2	Wedge Bonder on Shipping Board . . . . .	1	-	4
Figure 1-3	Main Head Packaging -Inner Right Side . . . . .	1	-	6
Figure 1-4	Z Lever Packaging . . . . .	1	-	6
Figure 1-5	Clamp Pads . . . . .	1	-	6
Figure 1-6	Removing the Manipulator Locking Rod . . . . .	1	-	7
Figure 1-7	Spotlight Mount Rod and Screw . . . . .	1	-	10
Figure 1-8	Spotlight Cord Routing . . . . .	1	-	10
Figure 1-9	B&L Microscope Installation . . . . .	1	-	11
Figure 1-10	WILD Microscope Installation . . . . .	1	-	12
Figure 2-1	Model 4123 Wedge Bonder - Main Parts . . . . .	2	-	2
Figure 2-2	The Main Head Assembly . . . . .	2	-	3
Figure 2-3	The Bonding Head . . . . .	2	-	5
Figure 2-4	Tear and Tail Control System . . . . .	2	-	6
Figure 2-5	The Spotlight . . . . .	2	-	8
Figure 3-1	Left Control Panel . . . . .	3	-	4
Figure 3-2	The Right Control Panel . . . . .	3	-	7
Figure 3-3	The Chessman . . . . .	3	-	9
Figure 4-1	Wedge Insertion Using Setup Gauge . . . . .	4	-	3
Figure 4-2	Microscope Focusing Controls . . . . .	4	-	6
Figure 4-3	Adjusting Workholder Height . . . . .	4	-	8
Figure 4-4	Wire Loading - 0.5" Spool . . . . .	4	-	10
Figure 4-5	Wire Loading - 2" Spool . . . . .	4	-	12
Figure 4-6	Force Adjustment Using Gram Gauge . . . . .	4	-	16
Figure 4-7	Wire Clamp Solenoids Adjustment . . . . .	4	-	18
Figure 4-8	The 1st Bond . . . . .	4	-	22
Figure 4-9	The 2nd Bond . . . . .	4	-	22
Figure 4-10	Good Loop . . . . .	4	-	22
Figure 4-11	Bad Loops . . . . .	4	-	22
Figure 6-1	Chessman Mode Bonding Cycle . . . . .	6	-	3
Figure 8-1	4123 Interconnections Schematic Diagram . . . . .	8	-	2
Figure 8-1A	4123 Interconnections Schematic Diagram for VDE . . . . .	8	-	3
Figure 8-2	4123 Mother Board Layout . . . . .	8	-	5
Figure 8-3	4123 Logic Board Block Diagram . . . . .	8	-	8
Figure 8-4	Logic Board Connector Points . . . . .	8	-	13
Figure 8-5	Logic Board Adjustment Points . . . . .	8	-	15
Figure 8-6	Base Back Cover . . . . .	8	-	19
Figure 8-7	Temperature Controller Schematic . . . . .	8	-	21

## LIST OF FIGURES

Figure 9-1	Main Head - Left View . . . . .	9 - 2
Figure 9-2	Main Head - Right View . . . . .	9 - 3
Figure 9-3	The Bonding Head Mechanism . . . . .	9 - 5
Figure 9-4	Push Rod Adjustment . . . . .	9 - 17
Figure 9-5	Verticality Adjustment - Side View . . . . .	9 - 22
Figure 9-6	Verticality Adjustment - Front View . . . . .	9 - 23
Figure 9-7	Clamp Solenoid and Wire Clamp . . . . .	9 - 24
Figure 9-8	Wire Clamp Position . . . . .	9 - 25
Figure 9-9	Wire Clamp Lateral Position Adjustment . . . . .	9 - 29
Figure 9-10	Tail and Tear Cams - Initial Positioning . . . . .	9 - 32
Figure 9-11	The Manipulator Assembly . . . . .	9 - 34
Figure 9-12	The Chessman Handle (Disassembled) . . . . .	9 - 35
Figure 9-13	The Underside of the Base . . . . .	9 - 36
Figure 9-14	The Manual Z Assembly . . . . .	9 - 42
Figure 10-1	Chessman Mode Bonding Cycle Time Study . . . . .	10 - 1

## LIST OF TABLES

Table 4-1	Suggested Initial Stroke Settings . . . . .	4 - 20
Table 8-1	Main Power Fuse Ratings . . . . .	8 - 4
Table 8-2	Logic Board 4123 Connector Points . . . . .	8 - 11
Table 8-3	Logic Board 4123 Adjustment Points . . . . .	8 - 14
Table 8-4	Test Points . . . . .	8 - 16
Table 11-1	4123 Fault Codes . . . . .	11 - 2
Table 12-1	Preventive Maintenance Schedule . . . . .	12 - 1

**INTRODUCTION**

The **K&S Model 4123 Wedge Bonder** is an aluminum and gold wire wedge bonder that can be used for bonding devices ranging from simple ICs and discrete devices up to complex hybrids with height variations up to 200 mil. The machine can operate in either the thermosonic or ultrasonic mode.



## Features

The following features are found on Model 4123:

- \* **DC SERVO/LVDT CLOSED LOOP CONTROL** of the Bonding Head means maximum speed between positions, with gradual starts and stops, minimum jarring and vibration, and high precision of vertical placement. Only one cam is required, with all sequence and timing functions controlled by electronic logic.
- \* **PHASE-LOCKED-LOOP (PLL) ULTRASONIC GENERATOR** and **HIGH-Q TRANSDUCER**. The High-Q Transducer is sensitive to changing load during bonding, and the PLL circuit enables the generator to track the resonant frequency of the ultrasonic circuit so that the bonding power is always delivered to the bond at the instantaneous frequency of the system. This means maximum efficiency, minimum power requirement and close control of the bonding process.
- \* **ELECTRONIC DIAL CONTROL** of bond forces, ultrasonic power, search and loop heights, and bonding duration.
- \* **AIR-DAMPED BONDING HEAD** that stabilizes the Bonding Head against shock and vibration and insures soft-touch impact.
- \* **WORK AREA** of 3.75" x 3.75" (95 mm x 95 mm) total bonding area.
- \* **CHESSMAN HAND CONTROL** a "single-hand" control that provides the operator with the following:

Fine positioning of the Workholder to bring the bonding area to the exact bonding position. Accomplished by a 6:1 translation of the movement of the Chessman to the Workholder.

The **CHESSMAN** pushbutton, located conveniently at hand on the Chessman Hand Control, for semi-automatic bonding. Pressing the pushbutton activates the Bonding Head and lowers the Wedge to just above the bonding surface, then stops to allow the operator to make fine positioning adjustments before bonding. Releasing the pushbutton allows the Bonding Head to drop to the bonding surface to make the bond.

The **STITCH** pushbutton that enables performing any number of stitch bonds.

- \* **DIAGNOSTIC LEDs** permit the fast localization of faults that may occur during machine operation. The machine performs a self-check upon initial power on or following a machine reset, any faults that are detected in the self-check cause the illumination of a combination of the LEDs from which the technician can determine the cause of the fault.
- \* **OVERHEAD MICROSCOPE** that permits full horizontal access to the work area.

### Optional Features

The following optional features are available for the Model 4123:

- \* **TEMPERATURE CONTROLLER** (K&S Model KTC-101 type J) that controls and digitally displays the temperature of the Workholder. Used in gold wire bonding operations.
- \* **MANUAL Z** that allows the operator to control all of the bonding operations manually. Very useful when bonding hybrid packages, or for bonding very fine wire.
- \* **SPOTLIGHT** that facilitates targeting by projecting a bull's eye pattern onto the bond site. A crosshair pattern for greater accuracy with narrower gauge wire.
- \* **WORKHOLDERS** - various types of stationary or motorized, heated or unheated Workholders are available.

For additional options and accessories, see Chapter 14.

## SPECIFICATIONS

The K & S Model 4123 Wedge Bonder has the following specifications.

## NOTE

These specifications are subject to change without prior notice.

## Wire

Diameter Range	
gold	0.5 to 3.0 mils (12 to 75 microns)
aluminum	1.0 to 3.0 mils (25 to 75 microns)
Spool Size	0.5" (12.5 mm) diameter
	2.0" (50 mm) diameter - optional

## Performance

Cycle time	1500 ms (incl. 100 ms bond time)
Bond force	10 to 160 gr, programmable range of 80 gr
Bond time	10 to 100 ms, or 10 to 1000 ms
Ultrasonic power	
(with 40 Ohm Load)	Low - 0.8 W. max
	High - 2.8 W. max

## Mechanical

Throat depth	5.5" (140 mm)
Wire Trajectory	30°/45° Standard
Reset to Overtravel	
(overall range)	0.2" (5.1 mm)
Table motion	0.5" (12.7 mm) diameter
Table load	6 kg max
Bonding area	3.75" x 3.75" (95 mm x 95 mm) max.
Chessman ratio	6:1
Tail length	Adjustable

## Electrical Requirements

Voltage	100/120/220/240 Vac $\pm$ 10%
Frequency	50 or 60 Hz
Power	70W max (without heated workholder)

## Physical Dimensions

	Machine	Shipping
Depth	26" (660 mm)	29.1" (740 mm)
Width	23.5" (597 mm)	26.8" (680 mm)
Height	26" (660 mm)	27.2" (690 mm)

**Weight**

Machine	64 lb (29 kg)
Shipping	110 lb (50 kg)

**Temperature Controller KTC-101 (Optional)**

Thermocouple input	Type J (Iron-Constant)
Indicating range	0°C to +400°C
Set-point range	+50°C to +400°C
Zero offset	±45°C total change
Accuracy	0.5% of full scale @ +25°C ambient temp.
Operating temperature	0°C to +50°C
Cold junction compensation	0°C to +50°C ambient temp.
Line voltage	120 Vac +10% to -20%
Load output	4A, 120 Vac - 240 Vac
Protection	Triac protected by internal fuse 4A fb

**SECTION ONE  
OPERATION**

**INSTALLATION**

This chapter contains instructions and guidelines for installing your **K&S Model 4123 Wedge Bonder**.

**UNPACKING AND INSTALLATION**

Your **K&S Model 4123 Wedge Bonder** comes packed in a reinforced container designed to provide complete protection during shipment. To remove the Wedge Bonder from its packaging perform the following steps:

- Step 1 Remove packing list from the pocket attached to the outside of the shipping carton (see Figure 1-1).
- Step 2 Cut the plastic bands which bind the carton (see Figure 1-1).
- Step 3 Open carton flaps. Remove the envelope containing the Wedge Bonder documentation from the inner lid (see Figure 1-1).
- Step 4 Lift out the two sponge slabs which separate the inner lid from the carton (see Figure 1-1).
- Step 5 Using a screwdriver (or any long flat tool), insert tool into a side gap of the inner lid, press aside as necessary and lift out the lid.
- Step 6 Remove the bubble sheet which covers the machine.
- Step 7 Lift Accessories Box out of its "cage" in front of the Wedge Bonder, open it and take out the box(es) containing the Wedge Bonder fixtures and accessories (see Figure 1-1).
- Step 8 Grasp the upper wooden bar of the machine sleeve and lift the sleeve out of the carton. As the sleeve fits tightly inside the carton, hold carton down with your other hand.

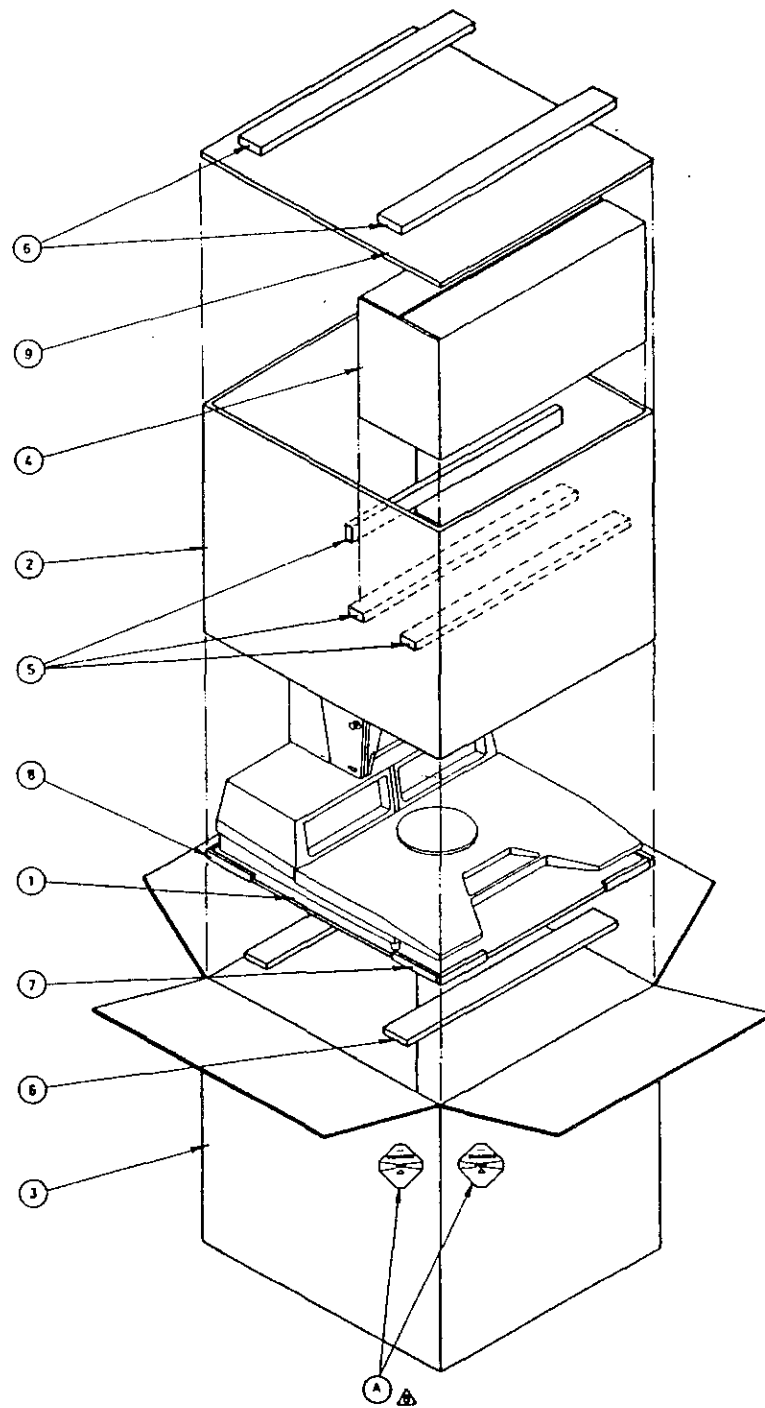

Figure 1-1 Wedge Bonder Packaging - Exploded View

Step 9 Remove the rubber band from around the upright part, the Main Head, of the Wedge Bonder (they hold the covers together). Open the covers (one on each side of the Main Head).

Lift the Wedge Bonder, with its attached shipping board, out of the carton and put it onto a cart. Two people are required for this: one grasping the two base armrests, the other pulling up on the bracket in the Main Head of the Wedge Bonder with one hand while holding down the carton with the other.

Step 10 Strip off the bubble sheet from the Wedge Bonder base (see Figure 1-2).

Step 11 From the bottom of the shipping board remove the shipping screws, spacers and shipping board from the base of the Wedge Bonder (see Figure 1-2) using a flat, 9/16" wrench.

Step 12 Put the Wedge Bonder where it is to be installed. Make sure that the Bonder rests on a stable platform in a still, draft free location. There is no need to bolt the machine to the platform.

Step 13 Remove the protective covering of the area light by cutting the twine at the ends of the woven sponge sleeve and slipping the sleeve off (see Figure 1-2).

Step 14 Strip off the masking tape which fastens the Chessman to the left arm rest.

Step 15 Open the box(es) containing the Wedge Bonder fixtures and accessories and check the contents against the packing slip.

If any part is missing or damaged, immediately notify the supplier and shipper.



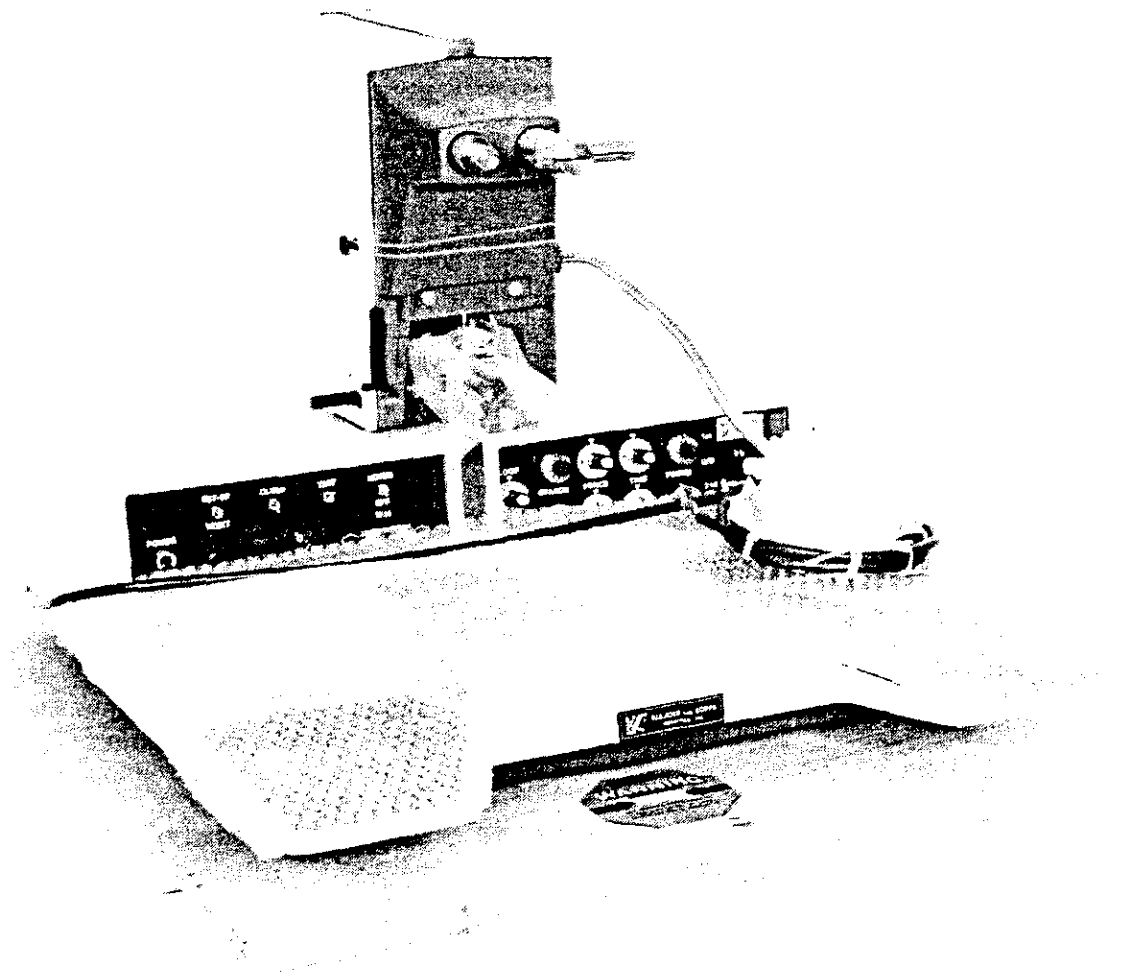

Figure 1-2 Wedge Bonder on Shipping Board

- Step 16 Inside the righthand side of the Main Head remove the rubber band which holds the Height Control Link to the main LVDT holder (see Figure 1-3).
- Step 17 Remove the sponge packing from between the Cam Pulley and the Height Control Link (see Figure 1-3).
- Step 18 Remove the protective packing from the Heel Ball (see Figure 1-3).
- Step 19 If your machine is equipped with the Manual Z option, remove the sponge packing from the slot under the Z-lever (see Figure 1-4).
- Step 20 Remove the small plastic pad from between the jaws of the Wire Clamp (see Figure 1-5).
- Step 21 Inside the lefthand side of the Main Head remove the rubber band that holds the Clamp Lifter to the door bracket and lower the Clamp Lifter.

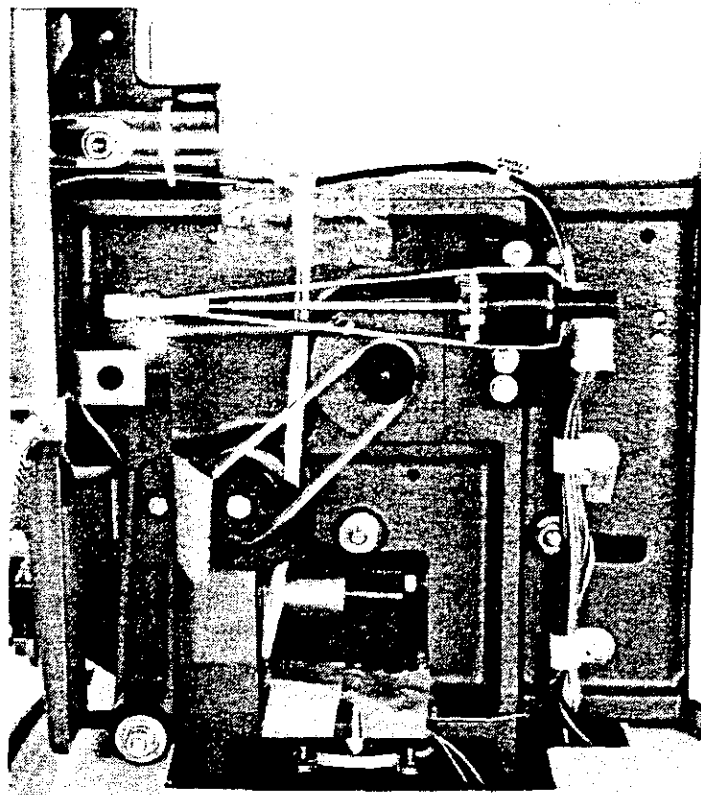

Figure 1-3 Main Head Packaging -Inner Right Side

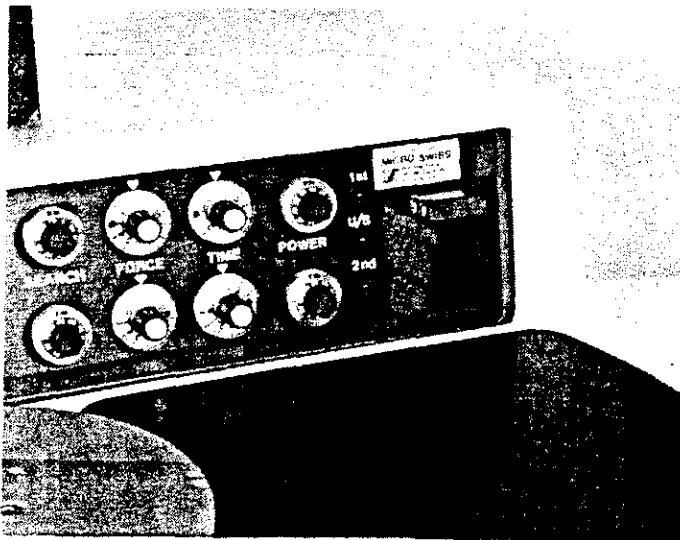

Figure 1-4 Z Lever Packaging

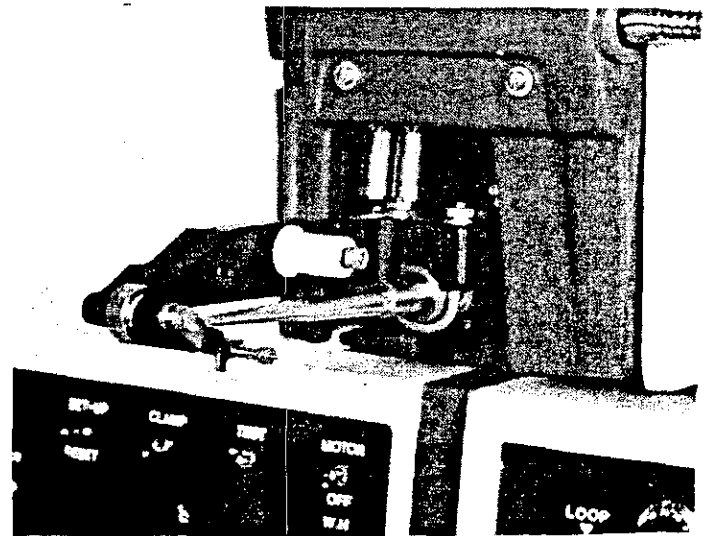

Figure 1-5 Clamp Pads

Step 22 Free the Manipulator assembly as follows (refer to Figure 1-6):

Pull the machine forward so that it projects beyond the table, and tilt it backwards to access the bottom of the machine. Be careful not to tip the machine over.

Using an Allen wrench, remove the two screws which secure the Manipulator assembly locking rod. Remove the rod (retain the rod for future use if the Wedge Bonder needs to be transferred to another location).

Slide the machine back into place on the table.

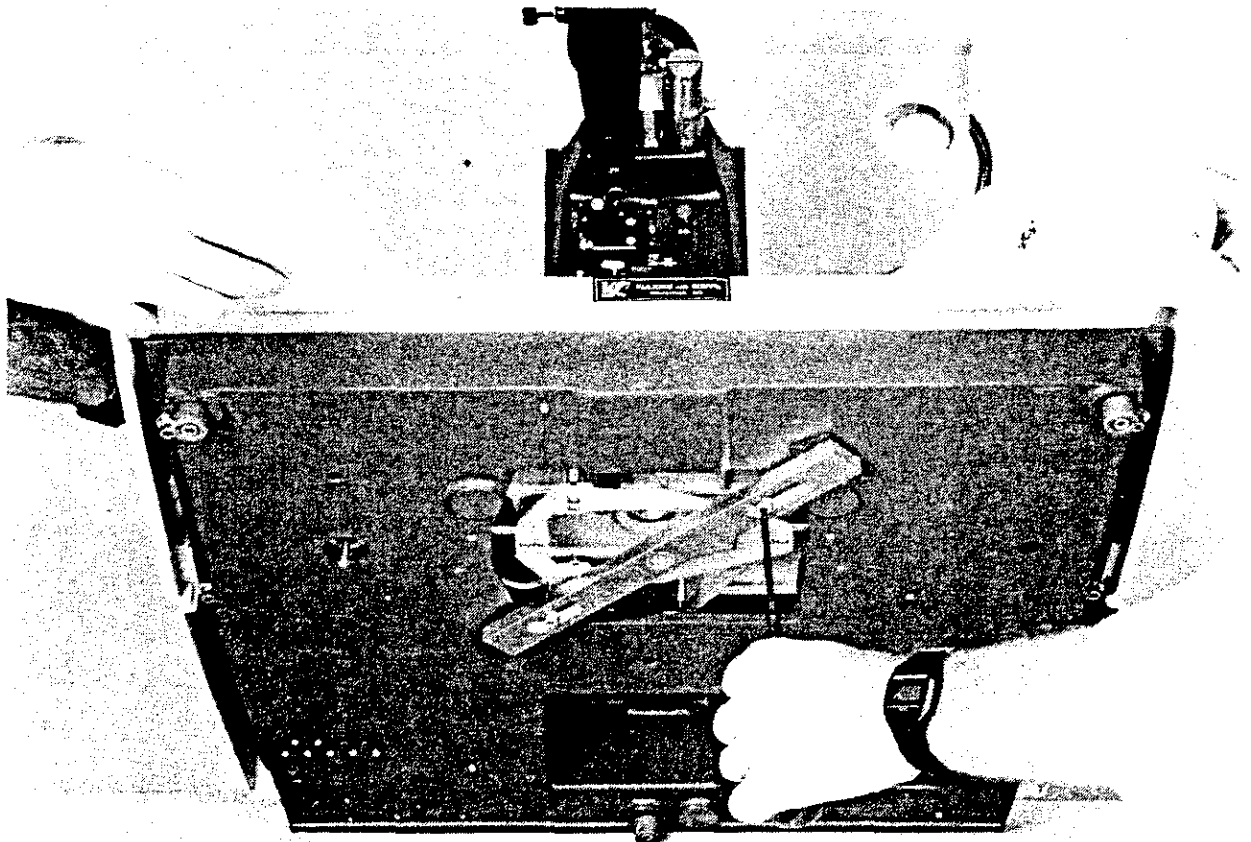

Figure 1-6 Removing the Manipulator Locking Rod

- Step 23 Uncoil the power cord. Check the Wedge Bonder name-plate for the operating voltage requirement, ensure that your mains supply the correct voltage. If not, contact your K&S representative.

**NOTE**

If no plug is connected to the cord, install a 3 prong plug which fits your mains. Note in particular the ground connection and remove the "GROUND" label.

**OPTIONAL ITEM INSTALLATION**

The procedures below cover the installation of the following optional items that may be included with your Model 4123 Wedge Bonder:

Spotlight  
Microscope Holder/Microscope

For other optional accessories, refer to the specific installation instructions that accompany them.

**Spotlight Installation**

- Step 1 Using an Allen wrench, loosen the spotlight mount clamping screw (see Figure 1-7). Remove mount from main head.
- Step 2 Insert spotlight mount into spotlight clamp and, using an Allen wrench, tighten the spotlight clamping screw about the correct side-tilt.
- Step 3 Insert spotlight cord through the spotlight mount hole in the main head front cover, insert spotlight mount (with spotlight attached) into the hole and, using an Allen wrench, tighten mount to main head frame.
- Step 4 Lead the spotlight cord from just below microscope support to the spotlight connector at the rear and plug it in (see Figure 1-8).

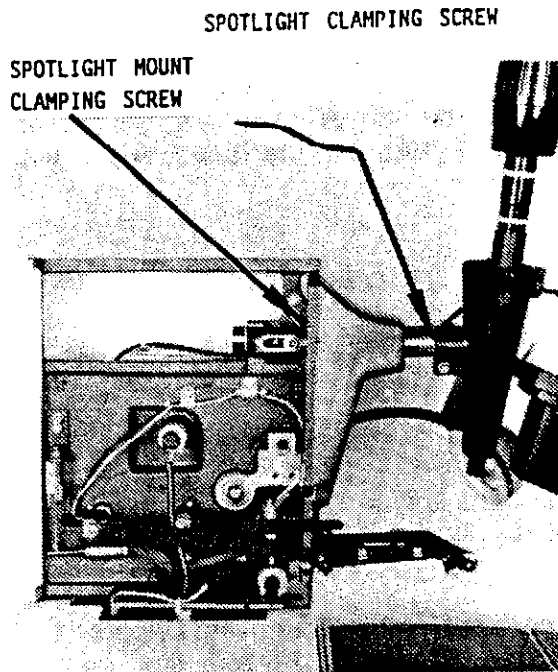

Figure 1-7 Spotlight Mount Rod and Screw

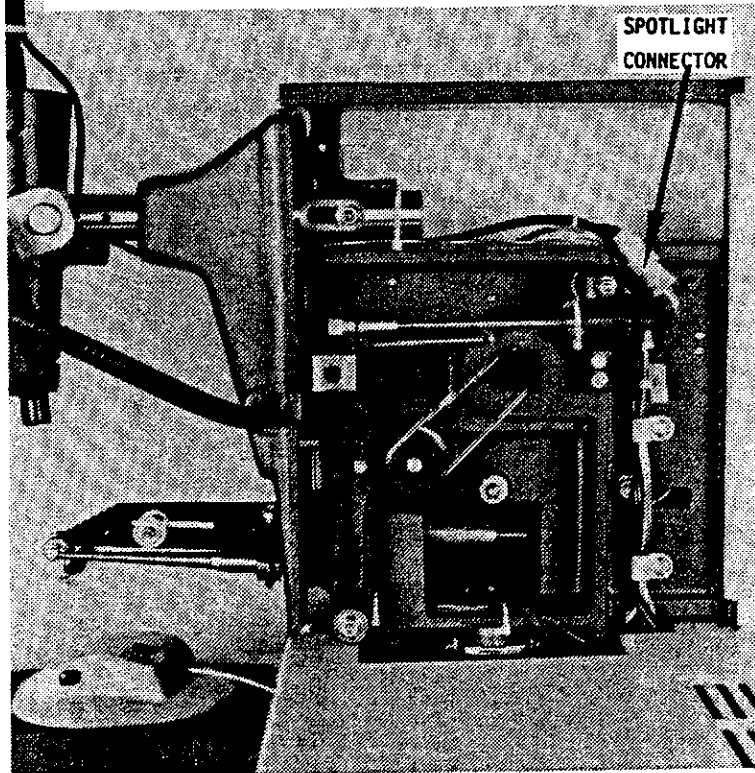

Figure 1-8 Spotlight Cord Routing

**B&L Microscope Holder/Microscope Installation**

- Step 1 Take the microscope holder out of the accessories box, unwrap and install it on the microscope support (see Figure 1-9).
- Step 2 Using a screwdriver, tighten microscope support screw.
- Step 3 If microscope is supplied, mount it on the holder bracket from top and fix by the two locking levers. Install the eye pieces in the oculars.

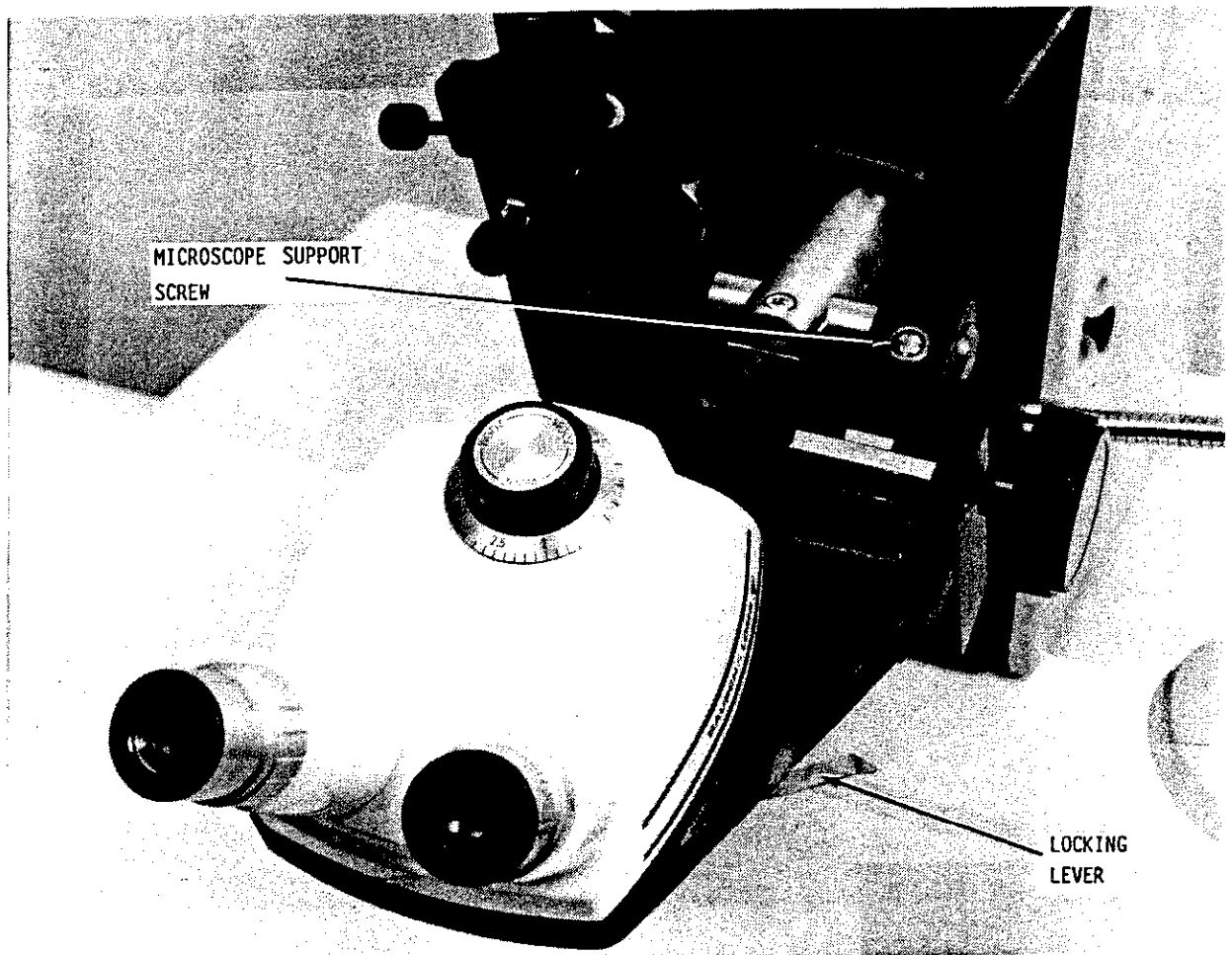

Figure 1-9 B&L Microscope Installation



### WILD M3Z Microscope Installation

The WILD M3Z Microscope comes as a complete assembly with its holder. Install the microscope assembly as shown in Figure 1-10 below.

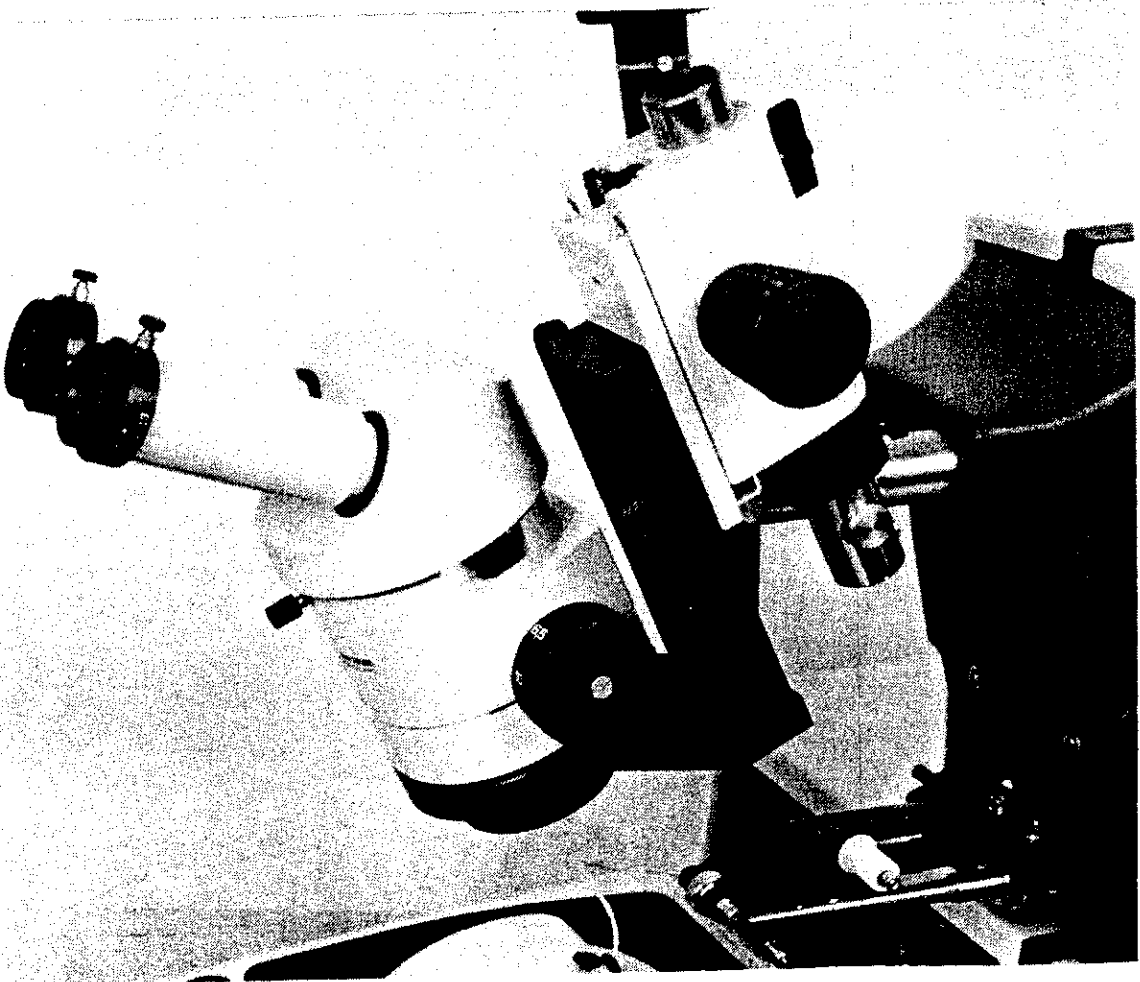

Figure 1-10 WILD Microscope Installation

## PHYSICAL DESCRIPTION

To familiarize you with your machine, this chapter provides a description of the principal parts of the K&S Model 4123 Wedge Bonder.

Figure 2-1 shows an overall view of the 4123.

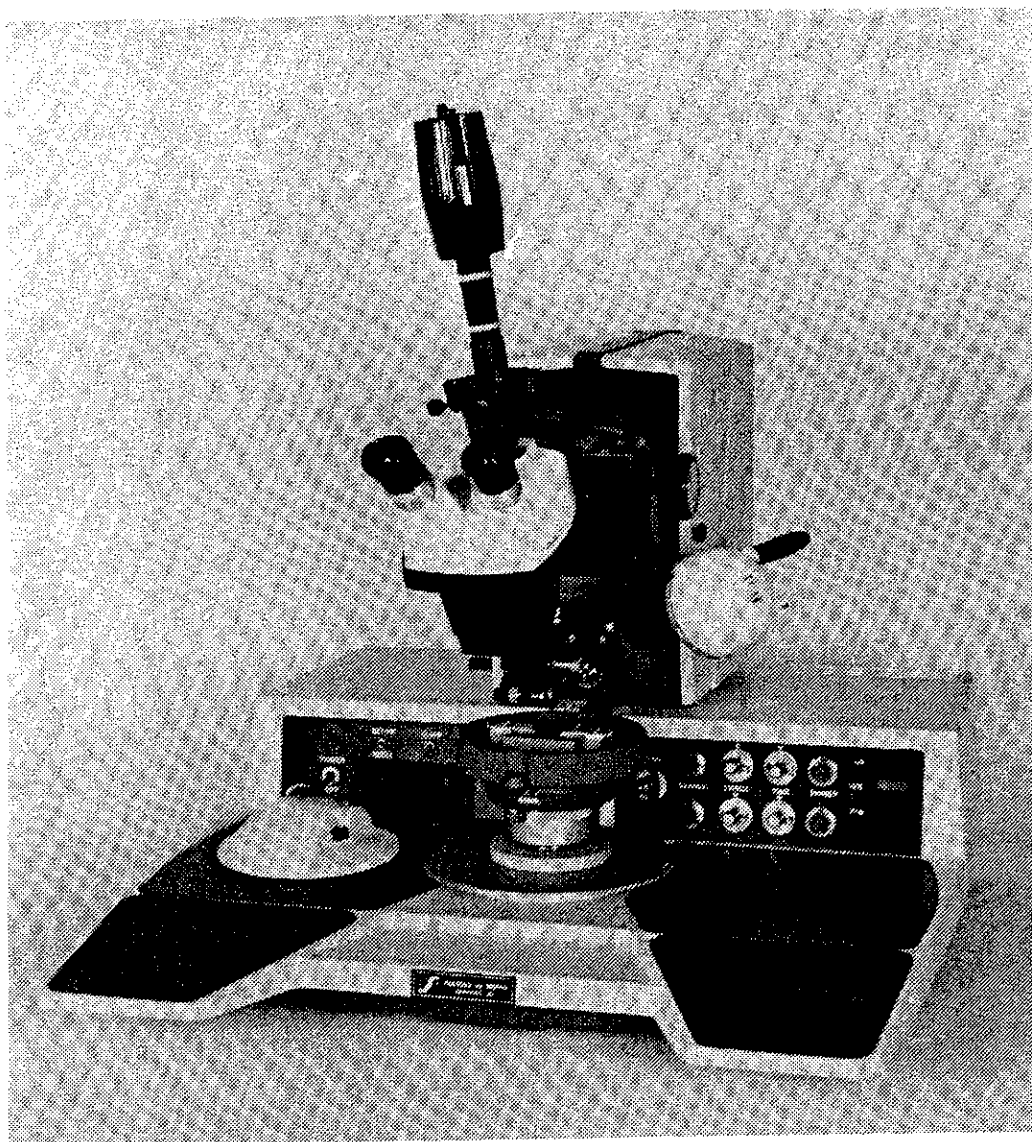

Figure 2-1 Model 4123 Wedge Bonder - Main Parts

THE MAIN HEAD

The Main Head contains the following subassemblies:

- \* Microscope (B&L or WILD)
- \* Bonding Head Placement & Force System
- \* Wire Tear and Tail Control System
- \* Area Light
- \* Spotlight (optional)

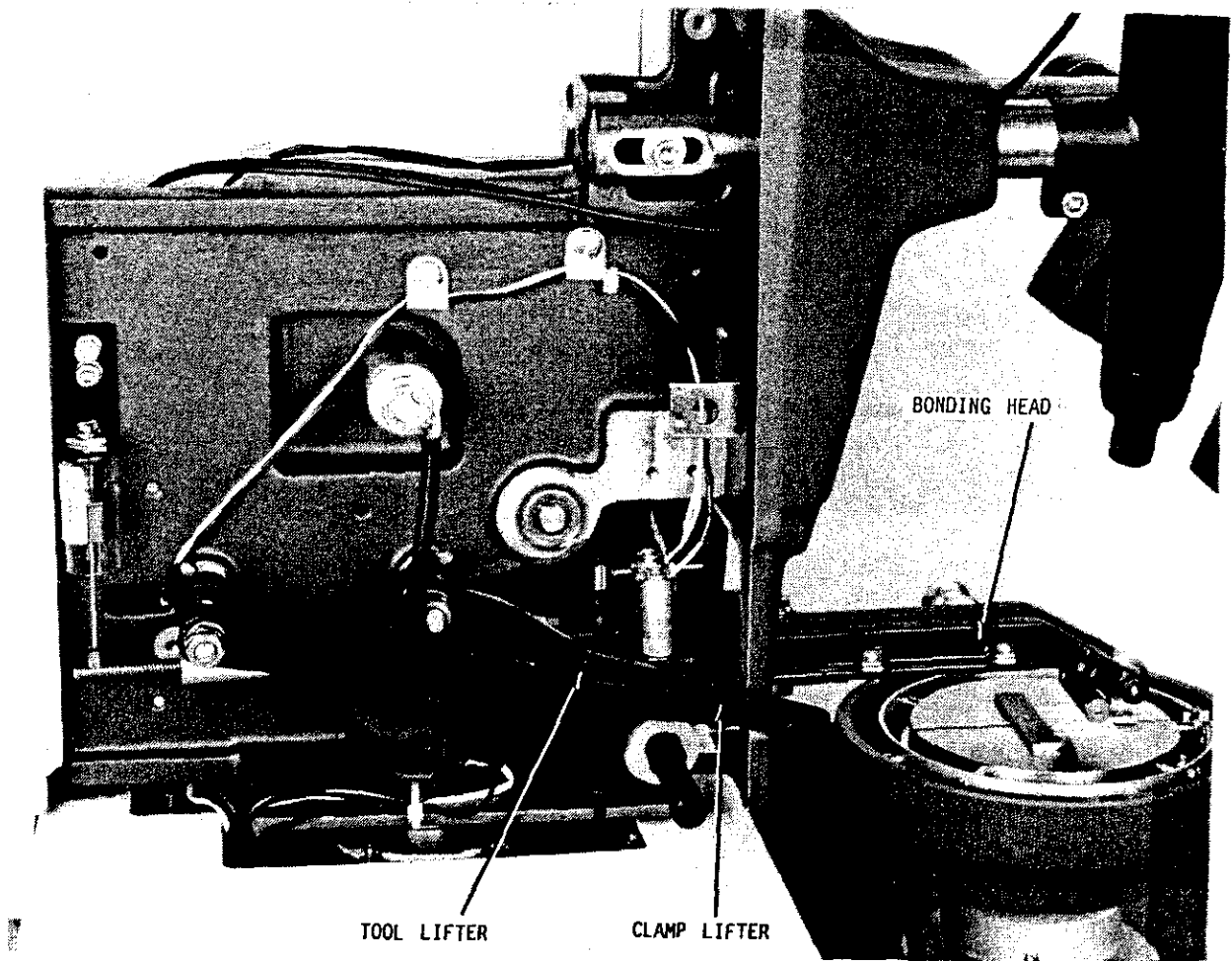

Figure 2-2 The Main Head Assembly

### Stereo Zoom Microscope

Your machine may be equipped with either a B&L or WILD Stereo Zoom Microscope. The microscope has both a common focus of both oculars and an individual focus for the left ocular. In addition, the microscope has an adjustable magnification zoom capability.

### The Bonding Head

(Refer to Figure 2-3)

The Bonding Head functions in a manner similar to that of a sewing machine needle. That is, it carries the wire to and from the bonding surface in the performance of the bonding cycle. The Bonding Head is pivoted in the Main Head frame and is driven by a dc servo motor.

The front end of the Bonding Head holds the Ultrasonic Transducer within which the Wedge is clamped. The wire bond process involves the application of three types of energies:

- \* Heat from the Workholder - if the wire is gold wire (aluminum wire is bonded at room temperature).
- \* Ultrasonic vibration of the Wedge tip. This is generated by the Ultrasonic Transducer that receives electrical energy from the Logic Board and translates into mechanical vibrations.
- \* Pressure (or Bonding Force) that is exerted by the Wedge on the wire. The Bonding Force is applied by an electromagnetic Force Actuator on the rear of the Bonding Head armature which is translated into a downward force at the front of the armature.

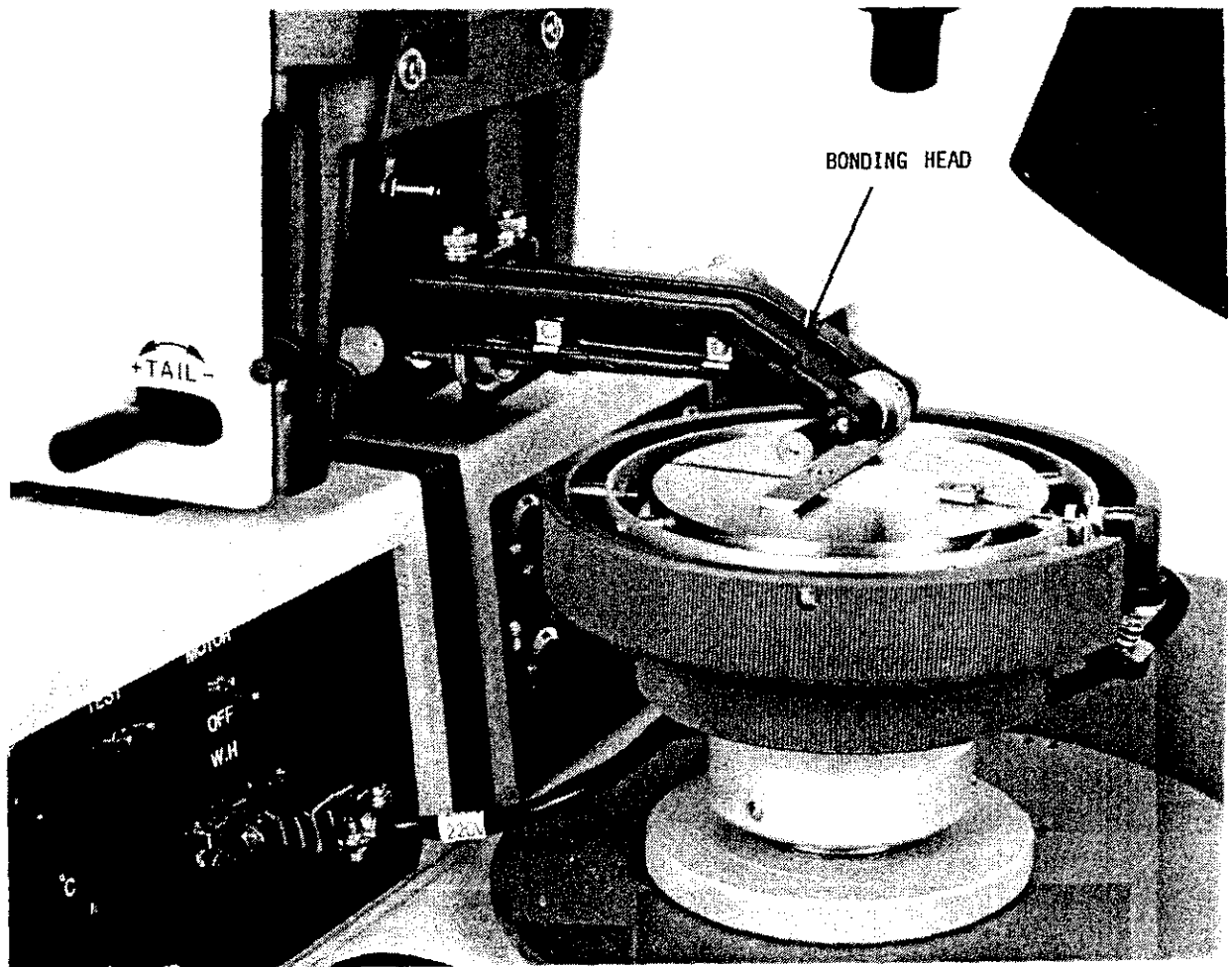

Figure 2-3 The Bonding Head

### Wire Tear and Tail Control System

(Refer to Figure 2-4)

After the second bond is performed, the wire has to be torn at the back of the Wedge foot in order to prepare the wire for the next first bond. After being torn, the wire is fed under the Wedge foot to form a protruding tail at the front of the Wedge.

Wire tearing and tail formation is accomplished by a wire clamp and pivot system. The Wire Clamp is mounted on a pivot within the Bonding Head casting. After the second bond when the Bonding Head starts to rise toward the Reset position, the Wire Clamp closes and rises according to the Tear setting, tearing the wire. The Wedge rises to the Reset position. The Wire Clamp drops down from the Tear position, feeding a wire tail through the Wedge feed hole in preparation for the next bond. Movement of the Wire Clamp is controlled by a Tear & Feed Bracket that, as it is lifted by the Tail (Zero) and Tear Solenoids, moves the Wire Clamp from one position to another.

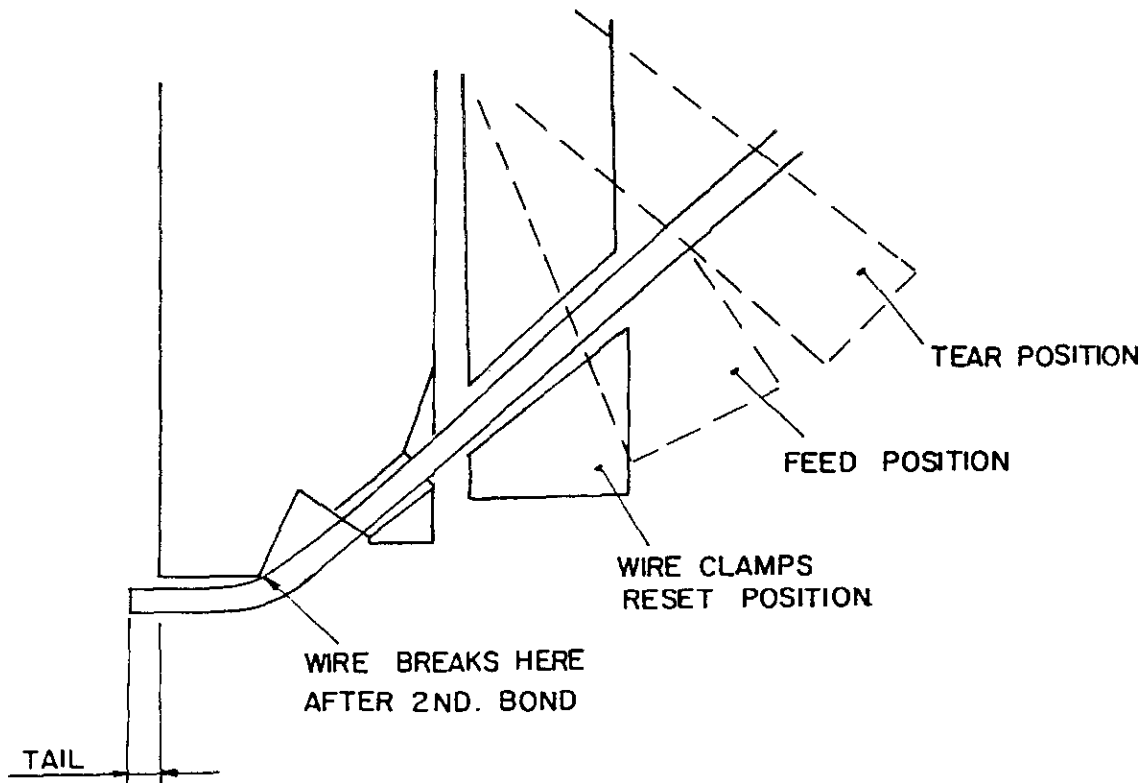

Figure 2-4 Tear and Tail Control System

### Tool Lifter

The Tool Lifter enables you to raise the front end of the Bonding Head manually for replacing Wedge, or protecting the Wedge when not in use. Raising the handle causes its lever to engage and lower the rear part of the Bonding Head, causing the Wedge to rise.

### Clamp Lifter

The Clamp Lifter enables you to move the Wire Clamp away from the back of the Wedge in order to thread the wire into the Wedge wire feed hole. The Clamp Lifter Handle is linked to an arm that raises the rear end of the Tear & Feed Bracket which in turn pivots the Wire Clamp to the rear position.

### The Area Light

The function of the Area Light is to provide sufficient illumination so that the work area may be viewed through the microscope.

It is fastened to the front of the Main Head frame by means of a flexible gooseneck. The Area Light is controlled by a switch located directly on the lamp housing.

### The Spotlight (Optional)

(Refer to Figure 2-5)

The Spotlight is an optional item that is available for the 4123. The Spotlight throws a bull's eye pattern on the bonding surface under the tip of the Wedge. In this way, the operator knows exactly where the Wedge will land when bonding.

Centering screws in the Spotlight cone enable the operator to center the spot onto the Wedge bonding surface target area.



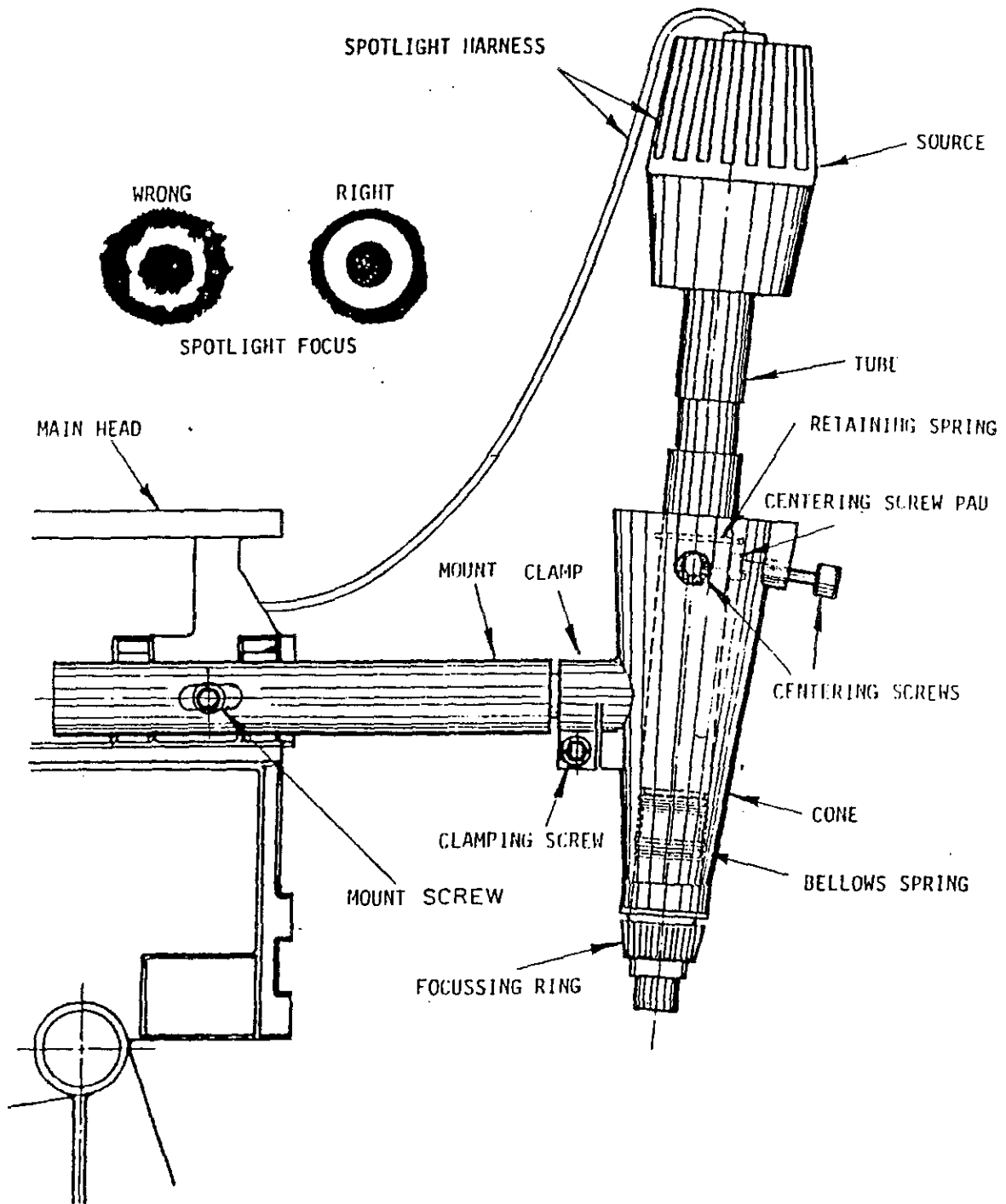

Figure 2-5 The Spotlight

## THE BASE

The Base houses the electronic and mechanical controls of the machine. The following subassemblies that are used by the operator are found on the Base:

- \* The Manipulator and Chessman
- \* Right and Left Control Panels

### The Manipulator and Chessman

The Manipulator supports the Workholder Table. The Manipulator glides on three ball bearing raceways that are mounted within the Base. The Manipulator can move, without backlash, only in the X and Y directions and is secured against rotation.

The Manipulator enables you to maneuver the device you are bonding to position the bonding pads under the Wedge. You can perform large scale motions by directly maneuvering the Workholder. For fine-tuning the device position, you use the Chessman.

The Chessman, located on the left side of the Base, is used primarily to make fine adjustments in the position of the Workholder. Through a system of mechanical linkages, the motion at the Chessman is translated, at a 6:1 ratio, to the Manipulator.

The Chessman also contains the CHESSMAN pushbutton for controlling the semi-automatic Chessman Mode bonding cycle, and the STITCH pushbutton that is used for performing Stitch Bonds in either the Chessman or Manual Z mode.

### The Right and Left Control Panels

There are two control panels (see Figure 2-1), the Left Control Panel and the Right Control Panel, located on the upper face of the Base. The Left Control Panel contains controls and indicators for electrical operations of the machine, such as turning the machine on or off and adjusting the Temperature Controller (if installed). The Right Control Panel contains the controls for setting the bonding parameters as well as indicators connected with the progress of the bonding cycle.

The controls and their functions are described in the next chapter.

## CONTROLS AND INDICATORS

This chapter describes all the K&S Model 4123 Wedge Bonder controls and indicators.

### THE LEFT CONTROL PANEL

The Left Control Panel, located on the left side of the Base, contains the following controls (see Figure 3-1):

**POWER/OFF** Switch used for turning the machine on and off. When in the up position (POWER), power from the mains is applied to the entire machine. When turning the power on, the machine performs an initialization cycle during which it tests the Logic Board circuits. During initialization, both 1st and 2nd indicators on the Right Control Panel illuminate.

**SET-UP/RESET** Three position switch used for measuring bond forces, for normal operations and for resetting the system.

Positioning the switch to SET-UP applies the bond force to the bonding head, according to which LED lights in the right panel: when 1st illuminates, the first bond force is applied - as preset by the respective FORCE dial (see Right Control Panel below); when 2nd illuminates, the second bond force is applied - as preset by the respective FORCE dial.

The switch in the mid position permits normal operation.

Pressing down on the switch to the RESET (momentary) position resets the machine to normal operations. This is used for recovering from a "hung-up" machine condition. For example, the machine can hang-up if the Wire Clamp is left open for more than 3 minutes (in which case the Wire Clamp Solenoid totally de-energizes). When the switch is released, it automatically returns to the mid position.

The RESET position is also used for making changes in the machine operation mode (see Chapter 5).

**CLAMP** Toggle switch used for opening the Wire Clamp for wire loading:

Placing switch in the up (CLAMP) position opens the Wire Clamp, and holds it open until the switch is once more placed in the down position. Normally used when the Bonding Head is in the Reset position. With the switch in the up position, the bonding cycle is suspended.

In order to avoid burnout of the Clamp Solenoid, if the switch is left in this position for more than 3 minutes, the machine hangs-up and has to be reset (see RESET above).

When the switch is in the down position, the machine performs normal operations.

**TEST** Toggle switch (momentary) used for checking the tuning of Ultrasonic Generator.

When held in the down position, internal circuits check the electrical correspondence of the Ultrasonic Generator with the frequency of the Transducer. If properly tuned, the U/S LED on the Right Control Panel illuminates. When the switch is released, it automatically returns to the up position.

**MOTOR/OFF** Toggle switch for turning the dc servo motor (Z Motor) on and off.

When set to the up (MOTOR) position, the Z Motor performs its normal operations.

Setting the switch to the down (OFF) position turns motor off. The Z Motor must be turned off whenever making mechanical adjustments on the Bonding Head mechanism or whenever the machine is not being used in order to minimize the risk of damaging or puncturing the device by the Wedge through the accidental pressing of the CHESSMAN pushbutton.

The following are part of the optional Temperature Controller which, when installed, is located in Left Control Panel.

**W.H** A jack for connecting the Workholder to the Temperature Controller.

**DISPLAY  
SELECT**

Pushbutton for selecting the Temperature Controller Digital Display for displaying either the actual Workholder temperature or the set-point (preset) temperature:

When pressed, the Digital Display displays the set-point temperature.

When released, the Digital Display displays the actual temperature.

**SET POINT**

Knob used for setting the temperature of the Workholder. As the knob is turned and the DISPLAY SELECT pushbutton is pressed, the temperature setting appears on the Temperature Controller Digital Display.

**Digital  
Display**

A three digit display that shows the temperature (in °C) of the Workholder, or, when the DISPLAY SELECT is pressed, the set-point temperature.

There are two indicators associated with the Digital Display:

**LOAD ON** which is a dot that appears under and to the right of the least significant digit. This dot illuminates steadily when the Temperature Controller is heating the Workholder. It starts blinking when the Workholder temperature is close to the set-point temperature, and goes out when the Workholder is at the set-point temperature.

**OPEN TC** which are two dots that appear under the two most significant digits. They appear whenever there is an open circuit in the thermocouple, or the Workholder is unplugged. When the OPEN TC indicator appears, the digits are blanked.

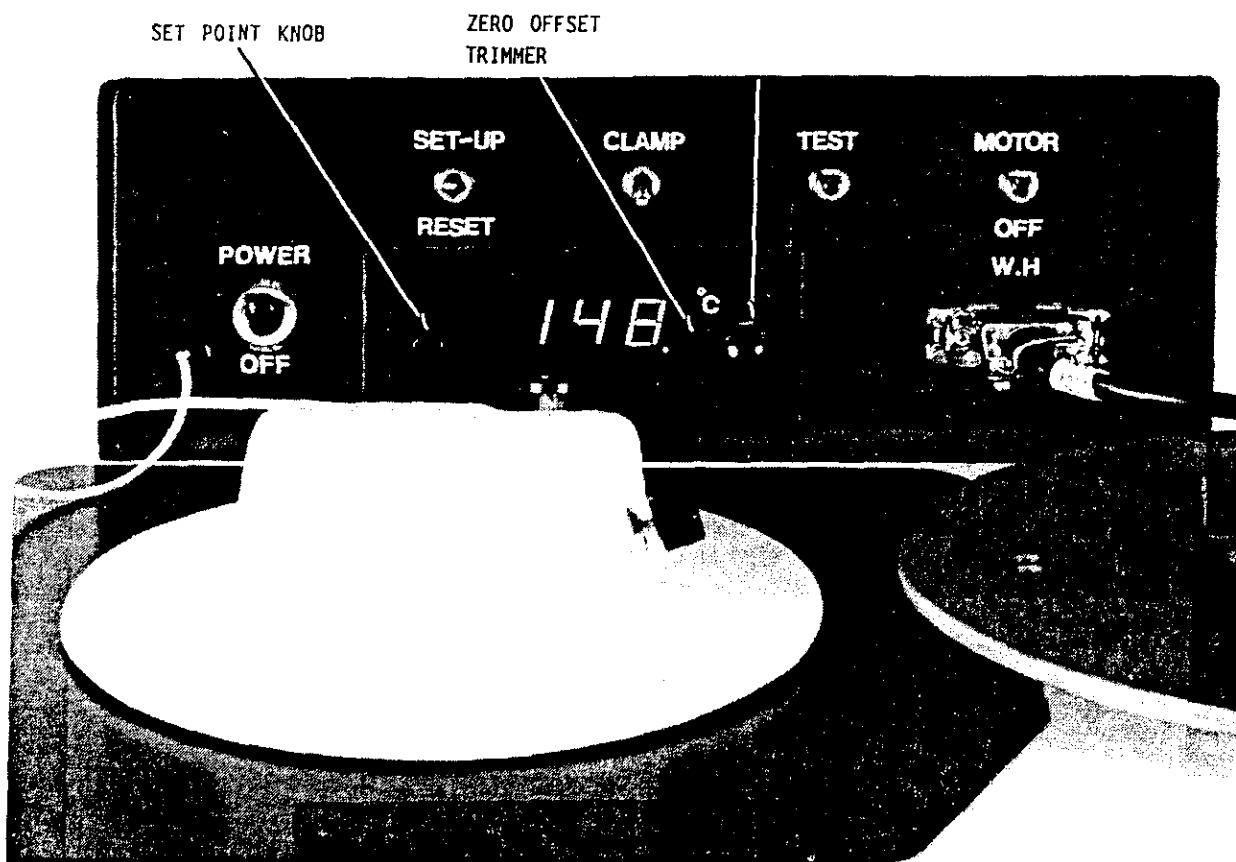

Figure 3-1 Left Control Panel

## THE RIGHT CONTROL PANEL

The Right Control Panel, located on the right side of the Base, contains the following indicators and controls (see Figure 3-2):

### Indicators

The Right Control Panel has three LED indicators:

**1st** This LED illuminates when the Bonding Head is in the Reset position indicating the start of the bonding cycle. It remains illuminated until the completion of the first bond. When this indicator is on, the bonding parameters are those set in the top row of dials.

**2nd** This LED illuminates when the Bonding Head is in the Loop position indicating that the bonding cycle has entered the second bonding stage. It remains illuminated until the completion of the second bond. When this indicator is on, the bonding parameters are those set in the bottom row of dials.

This LED will also illuminate flashing whenever the Wire Clamp has been left open for more than 3 minutes (to indicate that the Wire Clamp Solenoid has de-energized and the machine must be reset).

**U/S** This LED illuminates during bonding to indicate that the Transducer is active.

When the **TEST** pushbutton is pressed, the LED illuminates if the ultrasonic circuit is properly tuned.

### Dials

The Right Control Panel has two rows of dials that are used for setting the bonding parameters. The top row of dials is used for setting the parameters of the first bond, and the bottom row for setting the parameters of the second bond. In addition to the bottom row of dials, the LOOP setting determines the height to which the Wedge rises after the first bond.



The dials that set the bonding parameters are:

**SEARCH** regulates the height of the Bonding Head in the Search position.

The Search height is that height above the bonding surface at which the Wedge stops prior to performing bonding. This pause in the downward motion allows for stabilization of any vibration in the Bonding Head and enables you to align the bonding pad with the Wedge tip.

**FORCE** regulates downward force exerted by the Wedge on the wire.

The force exerted on the wire is the sum of the static weight of the Bonding Head, which is set by counterweights on the armature, and the dynamic force applied by the electromagnetic Force Actuator. The FORCE dials control only the dynamic force.

**TIME** regulates duration of the ultrasonic energy and bonding force pulse.

**POWER** regulates the ultrasonic power level. A high power setting increases the ultrasonic vibration amplitude, lowering the setting decreases the ultrasonic vibration amplitude.

**LOOP** sets the height to which the Wedge will rise after performing the first bond.

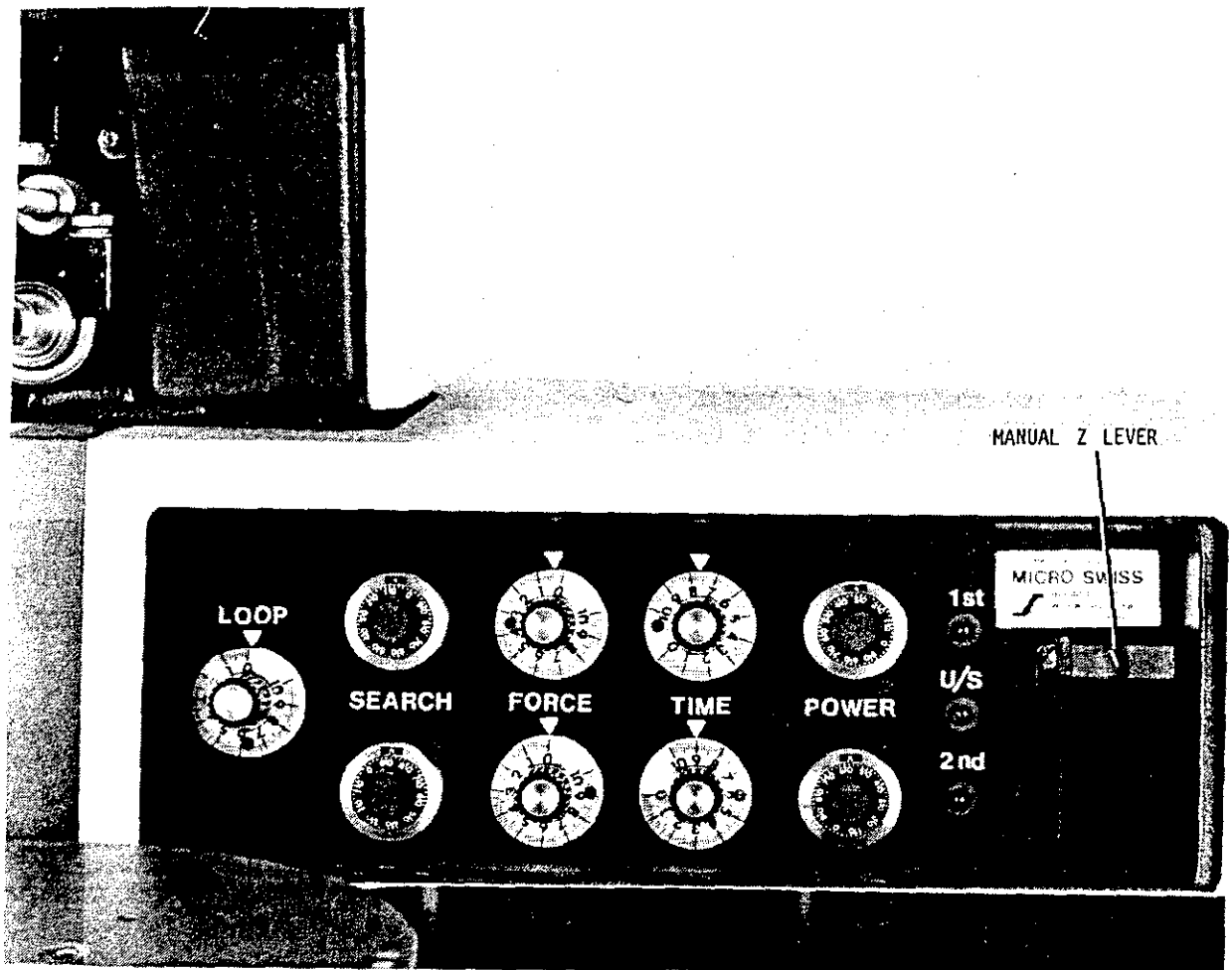

Figure 3-2 The Right Control Panel

### Z Lever Option

(Refer to Figure 3-2)

The optional Manual Z system is used for all applications where slow manual control of the bonding head is required, where great bonding height differences are encountered, and when high placement precision is required.

The Z Lever allows the operator to manually control the movement of the Bonding Head.

The Manual Z mode is activated by pressing down on the Z Lever. Pressing down on the Z Lever lowers the Wedge onto the device and starts the Manual Z cycle. Letting up on the Z Lever allows the Bonding Head to rise.

The Z Lever is spring-loaded. When the Z Lever is released after the second bond it automatically returns to the up position and the machine reverts to the Chessman mode, whereby the Bonding Head automatically returns to the Reset position.

**CHESSMAN**

(Refer to Figure 3-3)

The Chessman is located on the Base to the left of the Main Head. The Chessman serves two functions: one is to control the bonding cycle; the other is to enable the operator to make fine adjustments in the position of the Workholder under the Wedge.

There are two pushbutton controls located on the Chessman:

**CHESSMAN** located on top of the Chessman, when pressed it triggers semi-automatic bonding.

**STITCH** located on the side of the Chessman. After the first bond, depressing this pushbutton causes the machine to execute a Stitch Bond. The machine will continue making Stitch Bonds as long as the pushbutton is held in. When the pushbutton is released, the second bond must be performed in order to tear the wire.

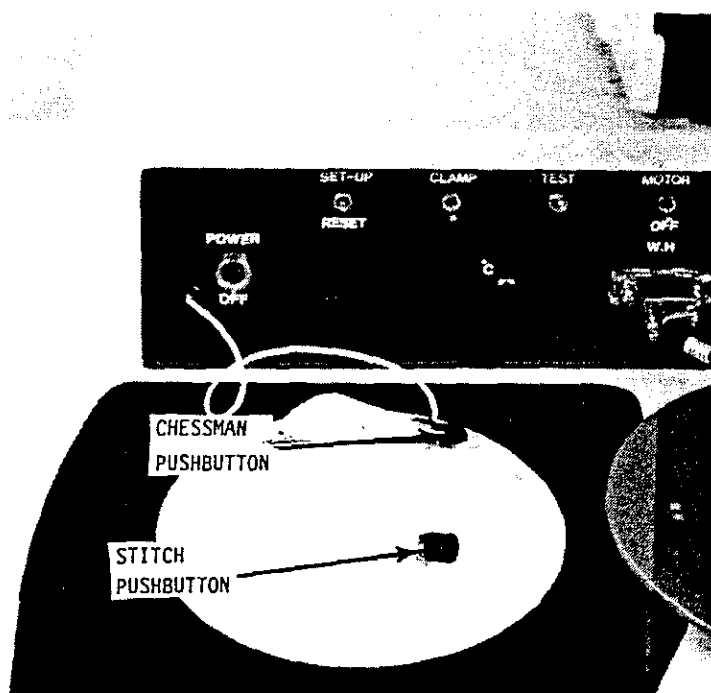

Figure 3-3 The Chessman

**SETUP AND ADJUSTMENTS**

This chapter contains the procedures and instructions for setting up and adjusting the **K&S Model 4123 Wedge Bonder** for operation.

Unless otherwise specified in your order, your machine has been adjusted and tested at the factory using K&S standard test devices.

A distinctive feature of the Model 4123 is ease of parameter setting. Many adjustments which required tools and mechanical procedures on other machines can be accomplished on the Model 4123 by simply turning dials. Before setting up the machine, familiarize yourself with its control panels.

Make sure to unpack and install the machine according to the instructions in Chapter 1. Then perform the following procedures, as needed, in the order given.

When performing these procedures, please heed the following cautions to protect your machine:

**CAUTION**

When threading a wire, always wear protective gloves. Never touch the Wedge or wire with your bare fingers as this will leave oil traces that are detrimental to proper operation.

**CAUTION**

When handling the Wedge, it is highly recommended that you use a good pair of tweezers such as **MicroSwiss Tool Tweezers, Model 43003-0010-001**. Improper handling can seriously impair the bonding operation of your machine.

**WEDGE INSTALLATION**

Take the small plastic bag containing the Wedge, Allen wrench and Setup Gauges out of the box containing the machine accessories and perform the following:

**NOTE**

There are two Setup Gauges supplied with the machine: one for the 0.750" long Wedge and one for the 0.828" Wedge. Although the machine can operate with either Wedge, it is recommended using the 0.750" Wedge. If the 0.828" Wedge is used, the Wire Clamp position should be readjusted (see procedure in Chapter 9).

- Step 1 With the Allen wrench, loosen the Wedge set screw located in the front of the Transducer and insert the Wedge. For best results, insert the Wedge such that the same amount sticks out the top of the Transducer tip as from the bottom. Then lightly tighten the set screw (so that the Wedge won't fall out).
- Step 2 With the Setup Gauge positioned under the Wedge, loosen the set screw and gently tamp the Wedge down until its tip just rests on the Setup Gauge (see Figure 4-1), then tighten the Wedge set screw.

**CAUTION**

When the Wedge tip is resting on the Setup Gauge, take care not to move the gauge as this can rub the Wedge causing damage to the tip.

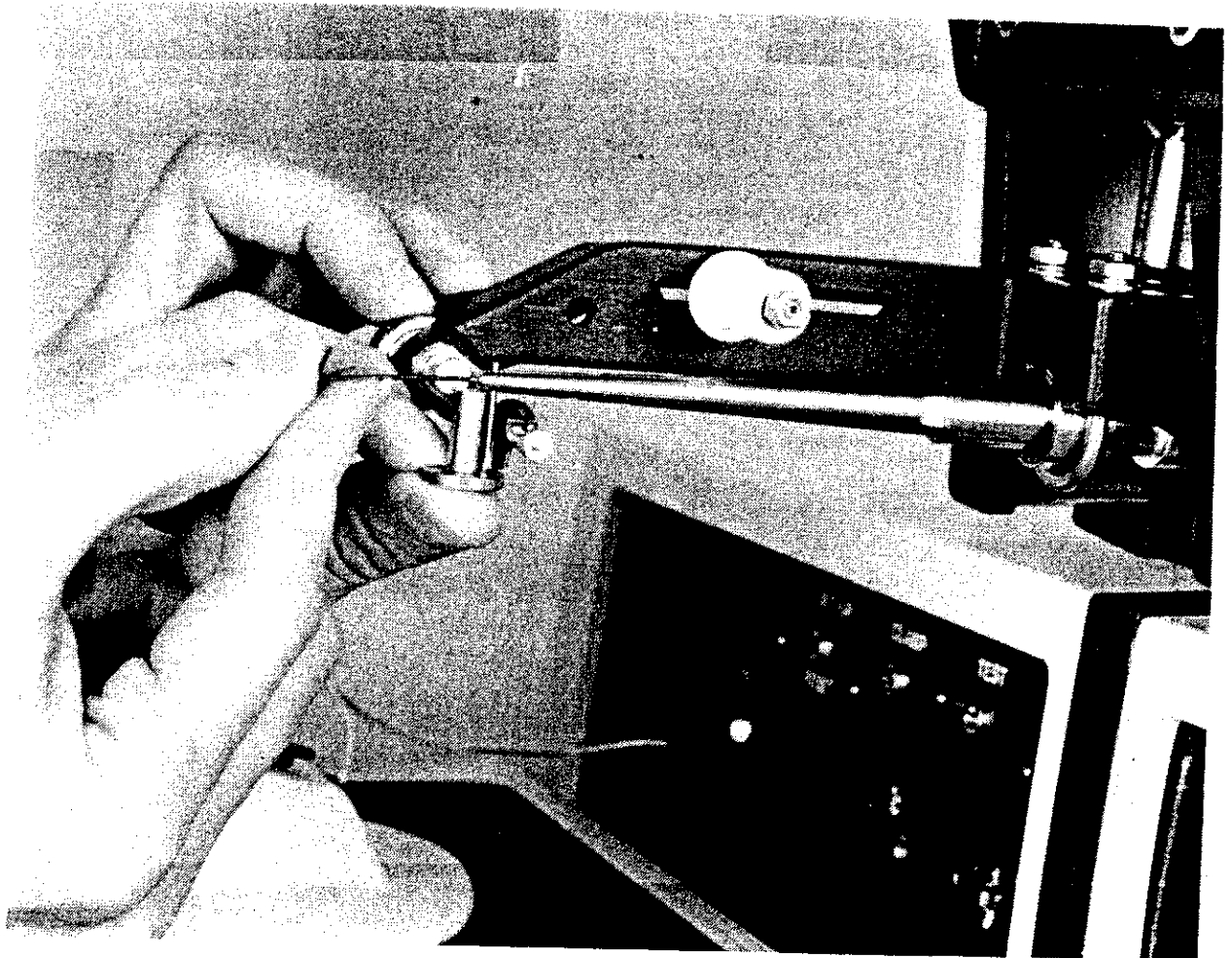

Figure 4-1 Wedge Insertion Using Setup Gauge

- Step 3 Turn the machine on. Note that indicators 1st and 2nd on the Right Control Panel illuminate.
- Step 4 Wait until the 2nd indicator goes out. Then press TEST on the Left Control Panel and check that the U/S indicator on the Right Control Panel illuminates.
- Step 5 It is recommended that you wait at least 30 minutes until the machine warms up.
- Step 6 When only the 1st indicator is illuminated, test for a tuned condition of the ultrasonic circuit as follows: press down momentarily the TEST switch on the Left Control Panel and check that the U/S indicator on the Right Control Panel lights up.

If it does not, readjust the Wedge insertion depth and set screw torque.



---

**MICROSCOPE ADJUSTMENT** ✓

Refer to Figure 4-2.

- Step 1 Turn the Zoom knob for minimum magnification and turn on the Area Light.
- Step 2 Set the **LOOP** dial on the Right Control Panel to 0 (zero). Press and release the **CHESSMAN** pushbutton. This cycles the Bonding Head through the "first bond" leaving the Wedge in a "Loop" position.
- Step 3 Release the Microscope locking screw and swivel the microscope to the left or right, and pivot up or down until the Wedge tip can be seen in the center of the field of view. Turn the Focusing Knob until the Wedge is in sharp focus.
- Step 4 Turn the Zoom knob for maximum magnification and repeat Step 3 until the Wedge tip is sharply focused in the field of view.
- Step 5 Tighten the Microscope locking screw.

Other adjustments that can be made in addition to the Zooming and Focusing are:

- \* The distance between the eyepieces can be adjusted by pulling or pushing the oculars sideways.
- \* In order to compensate for differences in right and left eye focus requirements, once the microscope has been focused so that the image is sharp in the right eyepiece, the left eyepiece can be focused independently using the left ocular focus ring.

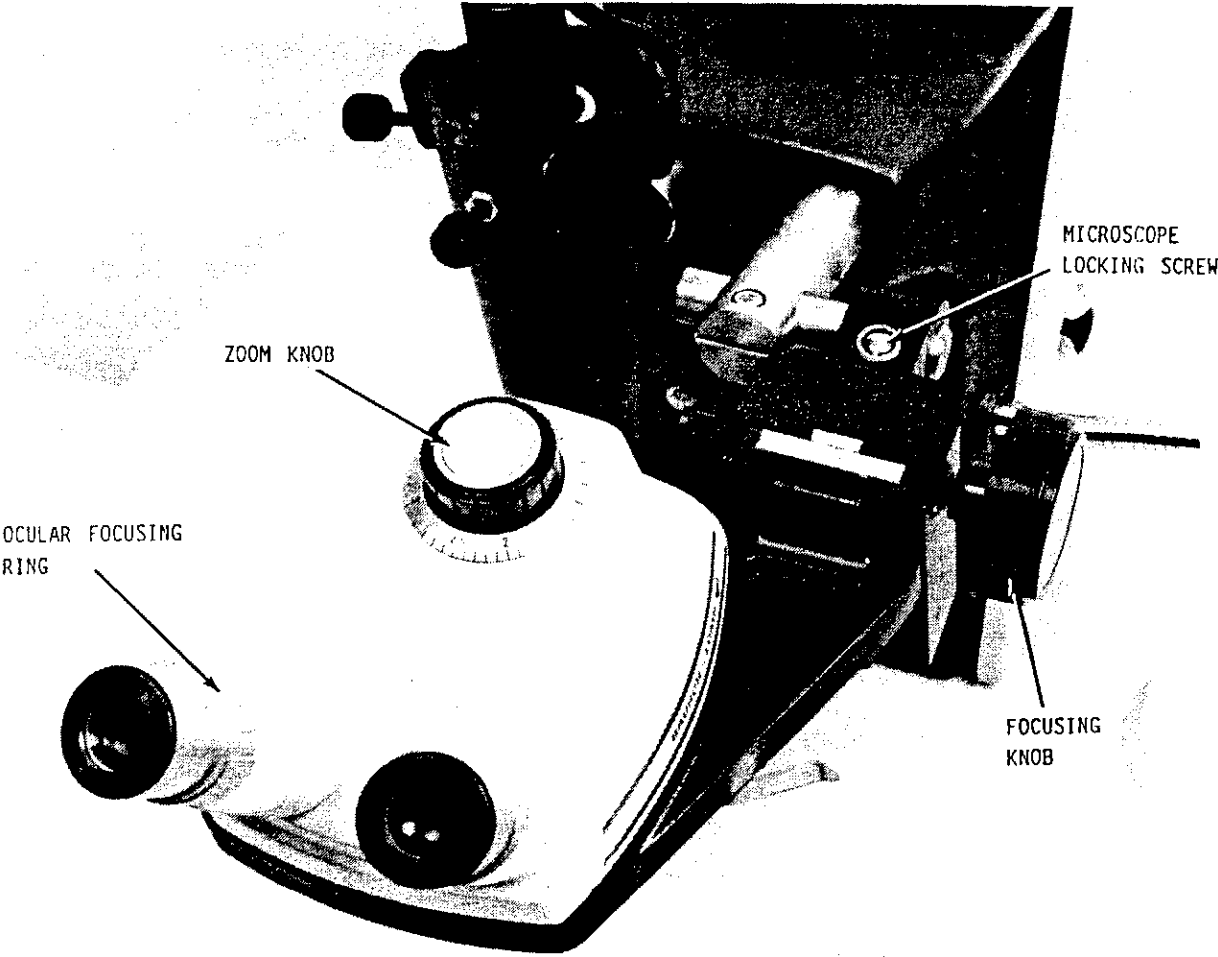

Figure 4-2 Microscope Focusing Controls

**WORKHOLDER INSTALLATION AND HEIGHT ADJUSTMENT**

(Refer to Figure 4-3)

**NOTE**

This procedure refers to manually height adjustable Workholders of type 483, 4142 or 4135. For motorized Workholders, refer to the instructions that are supplied with the Workholder.

- Step 1 Remove the package containing the Workholder from the box containing machine accessories, and unpack the Workholder.
- Step 2 Place the Workholder on the Workholder Table and while keeping the Workholder base flat on the Workholder Table, turn it counter-clockwise until it stops. This brings the Workholder to its lowest height.
- Step 3 If using a heated Workholder, plug the cord from the Workholder into the W.H jack located on the Left Control Panel.

To secure maximum range of bonding heights while preserving the required overtravel, it is desirable to adjust the Workholder height so that a device placed on it will just touch the Wedge tip when at the lowest possible Search position (i.e., SEARCH = 0). The steady-state LOOP = 0 position, which is identical to SEARCH = 0 as regards Bonding Head placement, is preferred to permit Workholder adjustment.

- Step 4 Load a device in the Workholder and adjust the Workholder clamps for proper clamping of the device. Set the LOOP dial to 0 (zero) and press and release the CHESSMAN pushbutton. This causes the Bonding Head to drop to its lowest position and remain there (make sure that the 2nd indicator is illuminated on the Right Control Panel). Now turn the base of the Workholder clockwise to raise the Workholder until the Wedge just touches the lowest bonding surface of the device.

- Step 5 Now increase the setting of the LOOP dial to 10, this raises the Wedge.
- Step 6 Press the CHESSMAN pushbutton to return the Bonding Head to the Reset position.

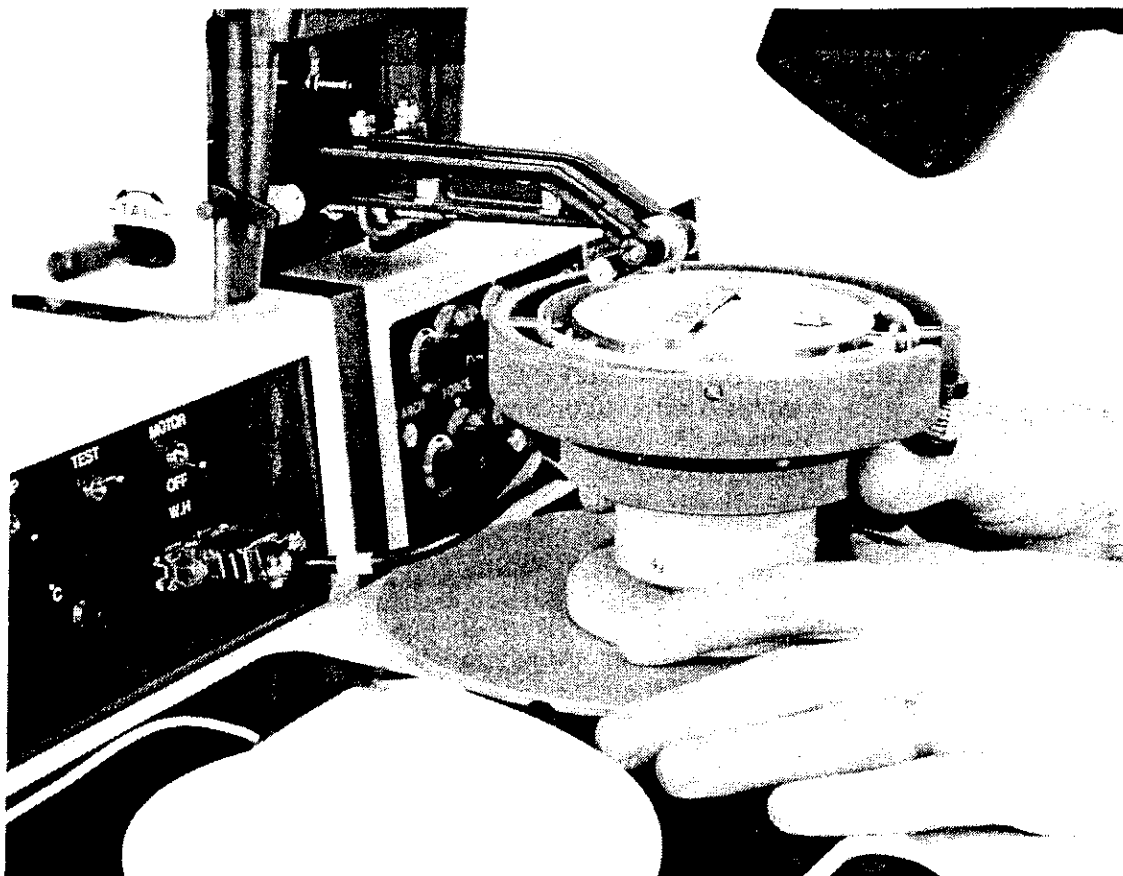

Figure 4-3 Adjusting Workholder Height

**SETTING WORKHOLDER TEMPERATURE**

To be performed if an optional heated Workholder is used.

**NOTE**

Make sure that the **TC OPEN** dots are not illuminated on the Digital Display. If dots are illuminated with no temperature displayed, check that the Workholder is plugged into the Temperature Controller properly.

- Step 1 Press and hold the **DISPLAY SELECT** pushbutton on the Left Control Panel (see Figure 3-1). This sets the Digital Display to show the temperature to which the Temperature Control is set.
- Step 2 Turn the **SET POINT** knob on the Left Control Panel until the desired temperature setting appears in the display (typical Workholder temperatures range between 120°C to 200°C).
- Step 3 Release the **DISPLAY SELECT** pushbutton. Check that the **LOAD** dot appears on the Digital Display (indicating that the Workholder heater is turned on).

**NOTE**

In order to calibrate the Temperature Controller according to the Workholder used, let the Workholder stabilize on the working temperature. Then measure the actual Workholder surface temperature using an external thermometer. Adjust the Zero Offset Adj. trimmer potentiometer (located to the left of the **DISPLAY SELECT** pushbutton on the Left Control Panel) until the temperature displayed in the Temperature Controller digital display matches that of the external thermometer.

**WIRE LOADING**

The standard Wire Spool Holder that comes with your K&S Model 4123 Wedge Bonder is for 0.5" Wire Spools. An optional 2" Spool Adaptor, however, can be used. The procedures for both types are given below, perform the one that matches the Spool Holder used on your machine.

**Wire Loading - 0.5" Spool**  
(Refer to Figure 4-4)

- Step 1 Make sure that the Bonding Head is in the Reset position (only the 1st LED indicator is illuminated on the Right Control Panel).
- Step 2 Slip the spool of wire on the Spool Holder on the right side of the Bonding Head.
- If a 30° Wedge is used, feed the wire from the bottom of the Spool Holder and insert it into the 30° wire feed hole of the Transducer.
- If a 45° Wedge is used, feed the wire from the top of the Spool Holder and insert it into the 45° wire feed hole of the Transducer.
- Step 3 Set the CLAMP switch on the Left Control Panel to the up position to open the Wire Clamp. Lift the Clamp Lifter handle up, and thread the wire through the Wire Clamp above the wire guide and through the wire feed hole in the Wedge.
- Step 4 Set the CLAMP switch to the down position to close the Wire Clamp and push the Clamp Lifter handle down.

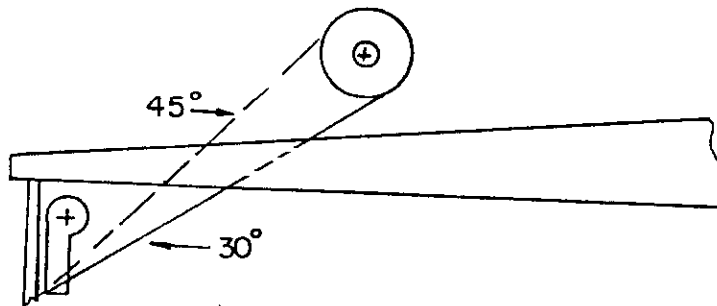

Figure 4-4 Wire Loading - 0.5" Spool

**Wire Loading - 2" Spool**

(Refer to Figure 4-5)

The optional 2" Wire Spool Holder is mounted to the Main Head casting using the two screws that secure the front Head cover to the casting.

- Step 1 Remove plastic Dust Cover, Spool Cap and glass Feed Tube from the Spool Holder. Place wire spool in Spool Holder.
- Step 2 While holding the glass Feed Tube in your hand, slip one of the rubber O-rings on the tube's pointed end. Slide it up until it is about 5/8-6/8" (15-18 mm) from the tube's flared end. Insert the pointed end of the tube through the Spool Cap, from the top. Slip the second O-ring on the tube from below, and slide it up until the Spool Cap is held fast between the two O-rings. Place the Spool Cap with the tube on the Spool Holder, flared end upward.
- Step 3 Bring free end of the wire, as marked by the manufacturer on the spool, with the end pointed upward up over the polished circumference of the Spool Cap and insert it into the flared end of the tube. Push down through the tube until it comes out of the lower, pointed end.
- Step 4 Place the plastic Dust Cover back on the Spool Holder, take care not to pinch the wire.
- Step 5 If a 30° Wedge is used, thread the wire through the 30° feed hole in the Transducer.  
  
If a 45° Wedge is used, thread the wire through the 45° feed hole in the Transducer. Also refer to Chapter 9 for the Clamp Position Adjustment procedure.
- Step 6 Set the CLAMP switch on the Left Control Panel to the up position to open the Wire Clamp.
- Step 7 Lift the Clamp Lifter handle up.
- Step 8 Thread the wire through the Wire Clamp above the wire guide and through the wire feed hole in the Wedge.
- Step 9 Set the CLAMP switch to the down position to close the Wire Clamp and push the Clamp Lifter handle down.

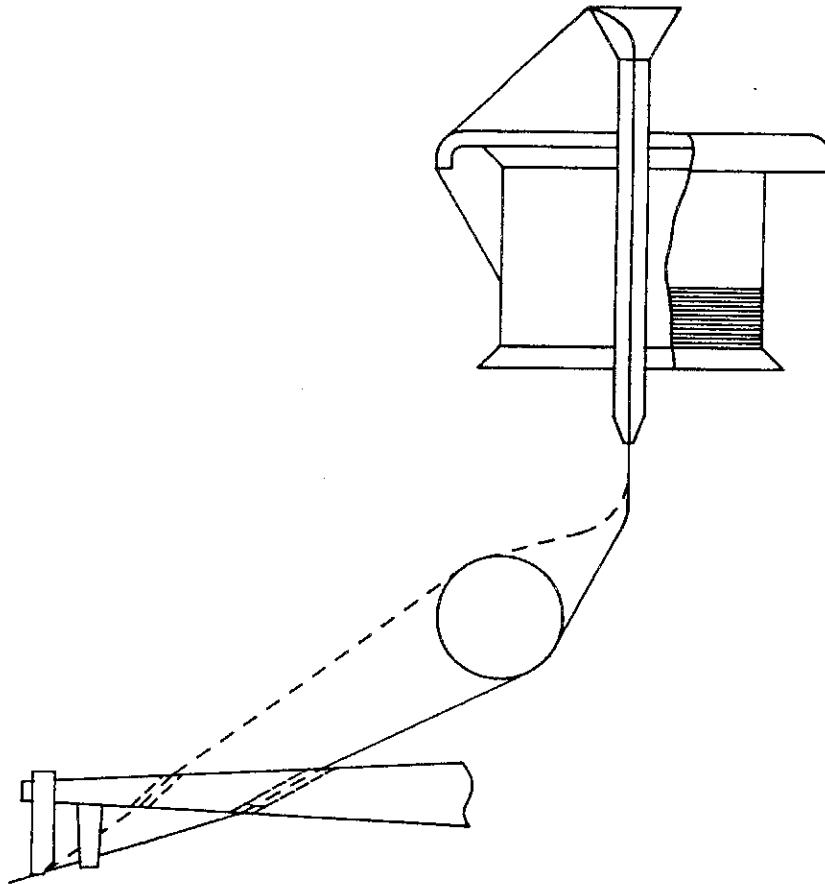

**Figure 4-5 Wire Loading - 2" Spool**

**NOTE**

The wire should lie along a straight line from the Transducer to the Wedge without bending. Otherwise friction may cause loop problems and damage to the wire. If the wire is not straight, refer to Chapter 9 for Wire Clamp adjustment procedures.



**Useful Tips for Wire Threading**

The following tips are offered by K&S to aid you in wire loading:

1. Always use good quality tweezers. Poor quality tweezers make wire threading difficult and may cause damage to the wire resulting in a blocked Wedge. Do not squeeze the wire too tightly with the tweezers. Squeezing can cause the wire to spread and get caught in the Wedge.
2. When threading a new wire, as when threading a sewing needle with thread, it's a good idea to tear off a bit of the wire lead in order to create a sharp point on the end of the wire. In this way, it will be much easier to insert the wire into the Wedge wire feed hole.
3. When threading the wire, hold the wire about 1/8" (1-2 mm) from the end.
4. Always use good quality Wedges. For best results, use MicroSwiss Wedges.
5. If the wire will not go through the Wedge wire feed hole, press the TEST switch on the Left Control Panel while threading the wire. Pressing the switch applies ultrasonic vibrations to the Wedge which will ease the passage of the wire.

**BONDING PARAMETERS**

The Right Control Panel contains the controls for setting the Bonding Parameters. The upper bank of dials is for setting the parameters for the first bond. The lower bank is for setting the parameters for the second bond.

The wire looping parameter is set using the LOOP dial.

The three main bonding parameters are set by the following dials:

POWER  
TIME  
FORCE

**Power**

Bonding Power is the amount of energy applied to the bond. High **POWER** dial settings result in high ultrasonic vibration amplitudes, lower settings in low vibration amplitudes.

The dial scale relates to the power setting of the Ultrasonic Generator. That is, the scale depends on whether the ultrasonic generator has been set to **LOW**, for wire thicknesses up to 2 mil (50 microns) or **HIGH**, for wire thicknesses in the range of 2-3 mil (50 to 75 microns). This setting is made by way of the HIGH/LOW switch located on the Base Back Cover.

**Time**

Bonding Time is the amount of time that the ultrasonic energy and force are applied. The scale of the **TIME** dial is relative to whether the time has been set to Standard Bonding Time or Long Bonding Time. These settings, and how to effect them are explained in Chapter 5.

**Force**

Bonding Force is the force exerted on the wire while the ultrasonic energy is being applied. There are two components to this force: one is the static force which is set by the position of the counterweights on the Bonding Head armature; the other is the amount of force applied by the electromagnetic coil which is set using the **FORCE** dial.

### Setting and Measuring the Bonding Force

Before setting the Bonding Force, make sure that the Bonding Head is in the Reset position (the 1st indicator alone is illuminated).

To set the Bonding Force:

- Step 1 Position the SET-UP/RESET switch on the Left Control Panel to SET-UP.
- Step 2 Remove the Workholder from the Workholder Table.
- Step 3 On the Right Control Panel, set both SEARCH dials to 0 (zero).
- Step 4 Press and hold the CHESSMAN pushbutton.
- Step 5 Using a gram gauge (see Figure 4-6), lift the Bonding Head until it starts to rise.
- Step 6 Read the gram gauge, this is the force applied for the first bond. Set the upper FORCE dial (the recommended value is between 25 to 30 gr for 1 mil wire).
- Step 7 Release the CHESSMAN pushbutton.
- Step 8 Press and hold the CHESSMAN pushbutton. The Bonding Head moves to the second Search position.
- Step 9 Using a gram gauge, lift the Bonding Head until it starts to rise.
- Step 10 Read the gram gauge, this is the force applied for the second bond. Set the lower FORCE dial (the recommended value is between 25 to 30 gr for 1 mil wire).
- Step 11 Release the CHESSMAN pushbutton.

#### NOTE

If the required Bonding Force needs to be lower than the minimum force or higher than the maximum force (i.e., FORCE = 0), the static force has to be readjusted (see Chapter 9).

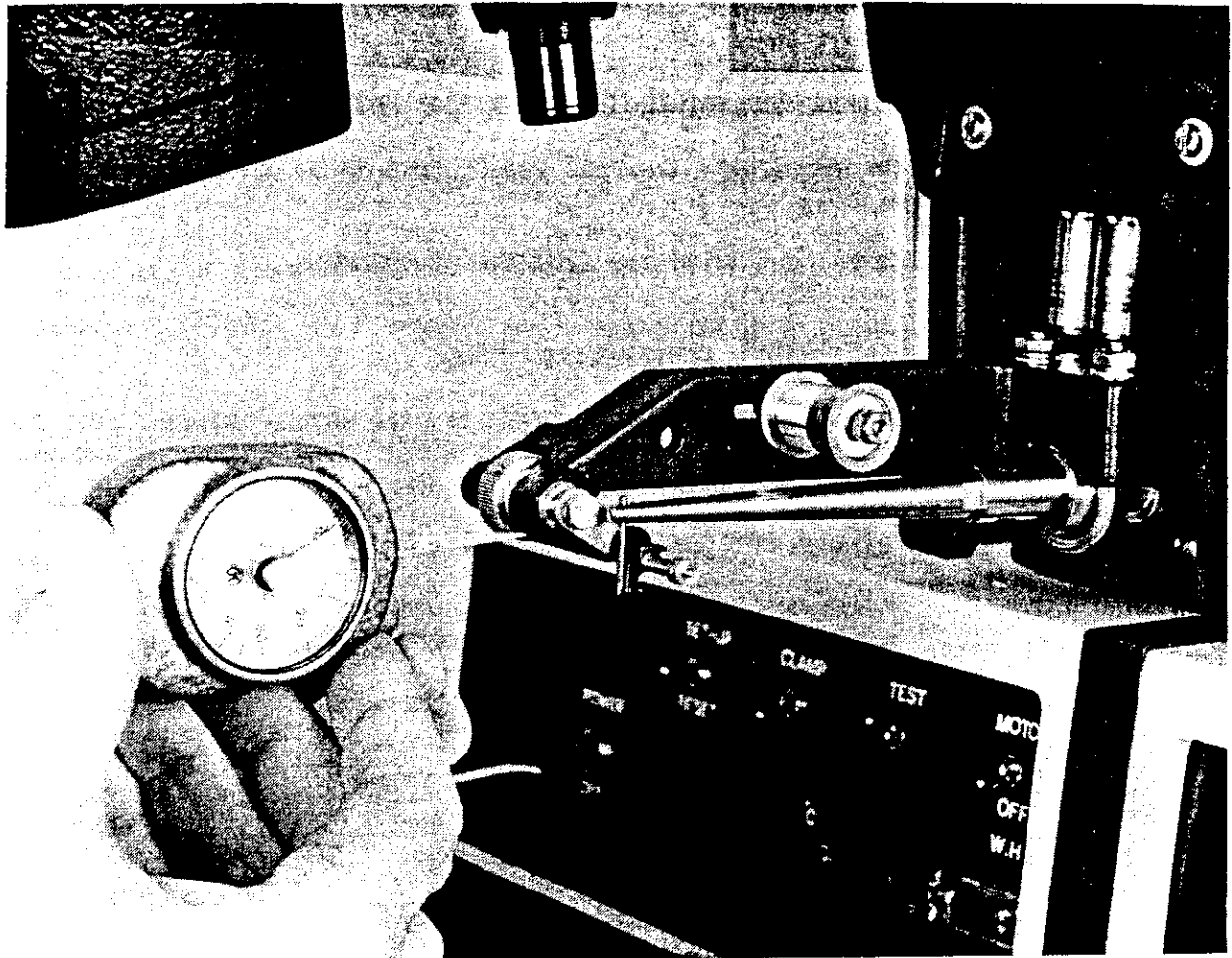

Figure 4-6 Force Adjustment Using Gram Gauge

**SETTING SEARCH POSITION**

The Search position is the height at which the Bonding Head stops above the bond site enabling the operator to perform fine positioning (via the Chessman) of the Workholder prior to bonding the wire. The Search position should be set at 3-5 mils (75-125 microns) above the bond site level.

Before setting the Search position, make sure that the Workholder height has been adjusted.

- Step 1 Turn the machine on. Note that the 1st indicator is illuminated.
- Step 2 Move the Workholder with the device to the first bond site. Set the upper SEARCH dial on the Right Control Panel to a high value (so that the Wedge does not hit the device's surface). Press and hold the CHESSMAN pushbutton. Note that the Bonding Head descends to the first Search position.
- Step 3 On the Right Control Panel, set the upper SEARCH dial to the desired Search height, between 3 to 5 mils (if you like, you can use a feeler gauge to determine the height setting value).
- Step 4 Release the CHESSMAN pushbutton. Note that the Wedge descends to the bond site and completes the first bond and then rises to the Loop Position and the 2nd indicator illuminates.
- Step 5 Set the lower SEARCH dial to a high value. Move the Workholder with the device to the second bonding site. Press and hold the CHESSMAN pushbutton. Note that the Bonding Head descends to the second Search position.
- Step 6 Repeat Step 3 for the lower SEARCH dial.
- Step 7 Release the CHESSMAN pushbutton. Note that the Bonding Head descends to the second bonding site, then rises to the Reset position.

### TAIL LENGTH AND TEAR ADJUSTMENTS

The amount of pivot motion of the Wire Clamp determines the tear point of the wire and the length of tail produced after tearing. This is an important consideration when setting up the machine for bonding.

The pivot motion of the Wire Clamp is controlled by two solenoids, one for the tear point and one for tail length. The stroke of these solenoids can be adjusted either for a common piston stroke or individual piston strokes.

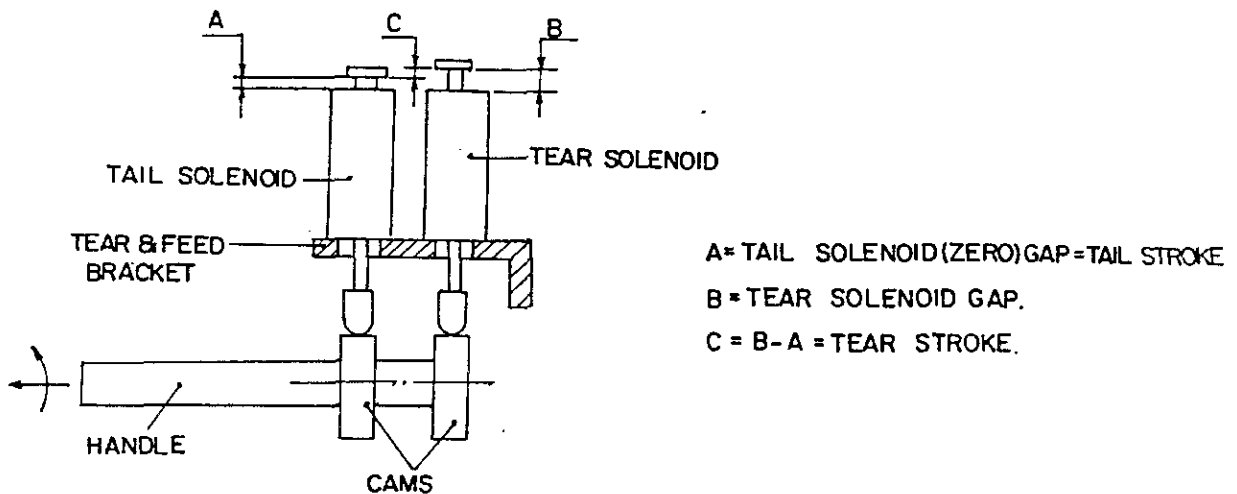

Figure 4-7 Wire Clamp Solenoids Adjustment

#### Tail Length Adjustment

Tail length is adjusted by turning the handle (see Figure 4-7). This sets the gap of the Tail Solenoid (Zero) and Tear Solenoid to the same stroke distance. This, in effect, affects only the tail length.

**Tear Point Adjustment**

Tear point adjustment is effected vis-a-vis the tail length. That is, by pulling the handle to the left and turning it, only the Tail Solenoid piston stroke is affected thereby creating a gap difference (C) between the Tail Solenoid gap (A) and the Tear Solenoid gap (B). Once the tear stroke (C) is established, push in the handle and readjust the tail length (see above).

The proper amount of tear stroke gap depends on the wire type and wire elongation factor. Table 4 - 1 below provides suggested initial values for gold and aluminum wires. Final values that you will use are arrived at after some trial and error and depend on the specific wire you use. Tail length settings depend on the bond length and type of Wedge used.

**Table 4 - 1 Suggested Initial Stroke Settings**

	Wire Type and Elongation			
	0.7 mil Gold 0.5-2%	1.0 mil Gold 2-4%	1.0 mil Al 1% Si 1-3%	3.0 mil Al 1% Si 1-3%
Tail Gap (A)	0.02" (0.5mm)	0.03" (0.75mm)	0.04" (1mm)	0.05" (1.25mm)
Tear Gap (B)	0.02-0.04" (0.5-1mm)	0.03-0.05" (0.75-1.25mm)	0.06-0.07" (1.5-1.75mm)	0.08-0.09" (2-2.25mm)
Tear Stroke (C)	0-0.02" (0-0.5mm)	0-0.02" (0-0.5mm)	0.02-0.03" (0.5-0.75mm)	0.03-0.04" (0.75-1mm)

## OPTIMAL BONDING SETTINGS

To optimize your machine operation, it is recommended that you bond a series of test wires, changing the bonding parameters (POWER, TIME, FORCE, etc.) one at a time to familiarize yourself with machine reaction to each parameter. Final parameter optimization should be performed only afterwards using the microscope, pull tester and shear tester.

Suggested optimal values for different wire materials are given below. You should use them as a starting point in finding those values that best fit your needs.

	0.7 mil <u>Gold</u>	1 mil <u>Gold</u>	1 mil <u>Al</u>	3 mil <u>Al</u>
Static Bond Force (gr)	5-10	15	15	50
Wire Clamp Gap (mil)	3	3-5	3-5	6-8
Wire Clamp Force (gr)	80-100	80-100	80-100	150
Tail Solenoid Gap (mil)	20	30-40	30-40	40-60
Tear Solenoid Gap (mil)	20	30-40	60-80	80-100
Bonding Parameters (Dials)				
POWER (Low)	0-2	0.5-2.5	1-2	4-8*
TIME	5-10**	5-10**	2-5	3-6**
FORCE(gr)	15-25	25-35	25-35	100-150
LOOP	1-2	2	2	4
Workholder Temperature	150°C	150°C	-	-

\* This value for 3 mil Aluminum wire is for POWER (High)

\*\* Longer bonding times

Search Height: about 0.005\* (0.127 mm) above the bonding pad

## Wires

Gold: the smaller the wire diameter, the harder the wire should be. The recommended elongation is 0.5-2%

Aluminum: use Al 1% Si wire with elongation of 1-3%



**Bonding Wedges:** for best results, use **MicroSwiss** Wedges. As a general rule, Titanium Carbide Wedges are best for gold wire, and Tungsten Carbide Wedges for aluminum wire. The preferred wedge length is 0.750", but the 0.828" length can be used.

Refer to the **MicroSwiss** catalog or consult your K&S representative in choosing the proper wedge for your application.

### **Bond Strength Optimization**

Bond strength depends on the following main parameters:

- \* Metalization - the bondability and the adhesion of the die and the substrate metals
- \* Wire type, tensile strength and elongation
- \* Type of Wedge used
- \* Bonding parameter settings
- \* Workholder temperature (for gold wire)

Because so many parameters affect the bond strength, the best way to optimize the bonding is by performing a series of tests such as pull testing the wire loop, microscopic analysis of the squashed wire dimensions and, preferably, using a Bond Shear tester. For each test, change only one of the bonding parameters until you get a set of parameters that meet your requirements.

You should be aware that the distance from the first bond to the second as well as the loop height will affect the results of pull test measurements.

The figures below are a guide to proper bonds and loops.



Figure 4-8 The 1st Bond

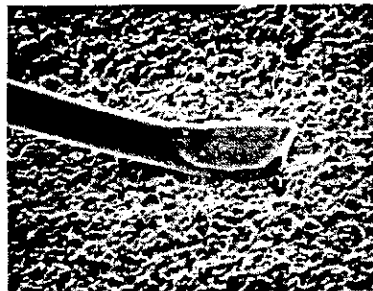

Figure 4-9 The 2nd Bond

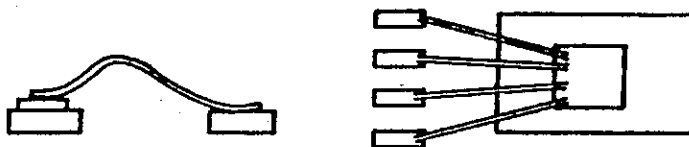

Figure 4-10 Good Loop



Figure 4-11 Bad Loops

**SPOTLIGHT ADJUSTMENT**

If your bonder is equipped with the optional Spotlight, perform the following:

**NOTE**

Before performing this adjustment, set the LOOP dial to its maximum setting (10). In this way, the Wedge will not interfere with the Spotlight beam.

- Step 1 Maneuver the device to a bonding pad.
- Step 2 Make a first bond on the bonding pad. Do not move the Chessman after the bond is performed. The Bonding Head should now be in the Loop position and the 2nd indicator on the Right Control Panel illuminated. The wire should be bonded to the bonding pad.

**Coarse Adjustment**

- Step 3 Loosen clamping screw on the Spotlight Cone.
- Step 4 Move the cone on the Spotlight mount so as to change the left/right aiming angle and forward/backward position of the spot of light, as required, until the targeting spot can be seen near the bonded wire.

**Focusing**

- Step 5 Turn the knurled focusing ring (located at the base of the Spotlight) until the target pattern appears as a sharp ring.

**Fine Adjustment**

- Step 6 Use the knurled screws near the top of the Spotlight cone to make fine adjustments in the position of the spot.
- Step 7 Reset the LOOP dial to its normal setting.

## BONDING TIME SETUP

The K&S Model 4123 Wedge Bonder comes from the factory set for a Standard Bonding Time of 100 ms (maximum) which is suitable for most applications.

The time scale of the TIME dials can be shifted to provide a maximum bonding time of 1000 ms (e.g., a setting of 3, instead of being 30 ms according to the Standard Bonding Time scale, would set the bonding time to 300 ms). These longer bonding times may be needed for low temperature bonding or for bonding applications where low ultrasonic energy is required.

The following procedure allows the operator to switch the TIME scale between Standard and Long Bonding Time (and vice versa):

- Step 1 Press the SET-UP/RESET switch on the Left Control Panel to RESET and then release. Simultaneously press and hold the STITCH pushbutton and the CHESSMAN pushbutton until the 2nd indicator on the Right Control Panel goes out.
- Step 2 Release both pushbuttons.
- Step 3 Press the STITCH pushbutton until you get the LED display on the Right Control Panel matching the desired time scale:

### Standard Bonding Time Scale

1st Blinks rapidly  
U/S Off  
2nd Off

### Long Bonding Time Scale

1st Blinks slowly  
U/S Off  
2nd Off

**BONDING OPERATION**

This chapter describes how to use the **K&S Model 4123 Wedge Bonder**. Details are given on both operator and machine actions during one bonding cycle.

There are three types of bonding operations that can be performed on the machine:

- \* Semi-Automatic Bonding using the CHESSMAN pushbutton.
- \* Manual Bonding using the Z Lever
- \* Stitch Bonding in the Chessman or Manual Z Mode

**Chessman Mode Bonding Cycle**

There are eight steps in the Chessman Semi-Automatic Bonding Cycle. These are described below. A graphic representation of the cycle is given in Figure 6-1.

**Step 1**

Start of the cycle. The Bonding Head is in the Reset Position. The operator positions the device for the first bond. The Wire Clamps are closed.

**Step 2**

The operator presses and holds the CHESSMAN pushbutton. The Wedge descends to the first Search position and stops. This allows the operator to make fine adjustments, as necessary, to the position of the bonding pad so that it is directly under the foot of the Wedge.

**Step 3**

The operator releases the CHESSMAN pushbutton. The Wedge descends to the first bond. The First Bonding Force and Ultrasonic energy, as set in the upper FORCE and POWER dials of the Right Control Panel, are applied for the amount of time set in the upper TIME dial. The first bond is performed and the Wire Clamp opens.

**Step 4**

The Wedge rises automatically to the Loop position, as set in the LOOP dial on the Right Control Panel. As the Bonding Head reaches the Loop position, the Tail Solenoid energizes and moves to the feed position.

**Step 5**

The operator maneuvers the Workholder towards himself, in a line parallel to the wire feed direction, until the second bond site is under the Wedge.

**NOTE**

The Wedge Bonding process is unidirectional, that is, it should be done in the direction of the wire. If wire must be bonded along a different orientation, the device should be rotated until the first bond and the second bond sites are aligned with the wire feed line.

**Step 6**

The operator presses and holds the CHESSMAN pushbutton. The Wedge descends to the second Search position and stops. As the Bonding Head starts its descent, the Wire Clamp closes momentarily to prevent the wire from feeding back into the Wedge feed hole (thus helping to create a stable loop). The operator makes fine adjustments, as needed, to bring the second bond site under the Wedge foot.

**Step 7**

The operator releases the CHESSMAN pushbutton. The Wedge descends to the second bond site. The Second Bonding Force and Ultrasonic energy, as set in the lower FORCE and POWER dials, are applied for the time duration set in the lower TIME dial. After the bond is performed, the Wire Clamp closes and rises according to the Tear setting, tearing the wire.

**Step 8**

The Wedge rises to the Reset position. The Wire Clamp drops down from the Tear position, feeding a wire tail through the Wedge feed hole in preparation for the next bond.

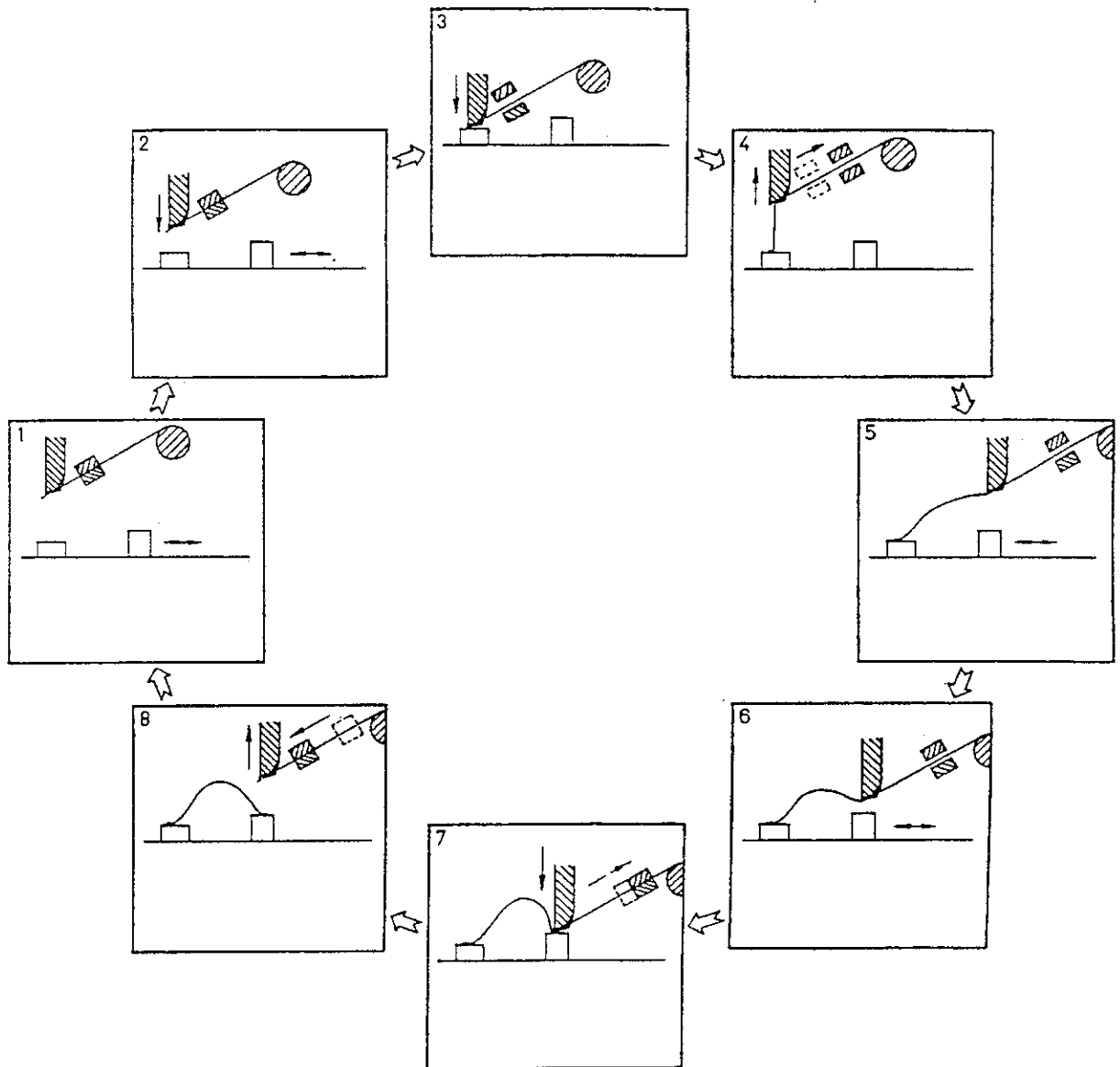

Figure 6-1 Chessman Mode Bonding Cycle

### Manual Z Bonding

Manual Z Bonding differs from the Semi-Automatic Chessman Mode as follows:

Using the Z Lever, you have full control of the motion of the Bonding Head. There are no preset Search and Loop positions in the Manual Z Mode, the position of the Bonding Head depends solely on the position of the Z Lever.

You move the Bonding Head up and down at will by moving the Z Lever up and down. By pushing down on the Z Lever you can bring the Wedge to a point that is as close as you wish to the bonding surface. Then make final positional adjustments of the device by maneuvering the CHESSMAN hand control. Pressing the Z Lever to its fully down position causes the Wedge to drop to the bonding surface and the bond is made as in the Chessman Mode.

The above is repeated for the second bond. Once the second bond has been accomplished, raising the Z Lever to the fully up position causes the Bonding Head to rise to the Reset position.

### Stitch Bonding

If you press and hold the STITCH pushbutton down after you have performed the first bond, the Wire Clamp will perform the second bond without tearing the wire as in Step 7 (see above). Instead it will continue to making bonds until you release the pushbutton.

After making one or more Stitch Bonds, release the STITCH pushbutton. Then make one more bond, the Bonding Head will rise to the Reset position and the wire tail will be formed.



**SECTION TWO  
MAINTENANCE**

**MAINTENANCE INTRODUCTION**

The K&S 4123 Wedge Bonder is a rugged, durable machine, designed to give years of trouble-free operation. However, like any machine, the bonder needs servicing and adjustments, and occasional repairs. This section of the manual provides all the information necessary for the technician when making repairs and adjustments is needed.

Throughout this section, it is assumed that the technician is thoroughly familiar with the operation of the machine.

**General Guidelines**

When working on the machine, adhere to the following general guidelines:

1. Always use the proper tools and equipment.
2. Never use other than K&S approved spare parts (a complete listing is found in Chapter 15).
3. If, after following a procedure in this manual, the problem is not resolved, refer the matter to your K&S representative. Do not attempt repairs beyond the scope of this manual.
4. Unless otherwise instructed, there is no need to put oil on any of the parts of the machine. Oil attracts dust that can interfere with the proper functioning of the parts.
5. With the exception of those adjustments that require operating the machine, all work should be accomplished with the machine turned off.

### Machine Adjustments Checklist

Because of the interdependency of the electrical and mechanical assemblies for proper machine operation, the following list of machine adjustments is given in the order of their priority:

1. 18 Vptp Adjustment (Chapter 8)
2. Reset Height Adjustment (Chapter 9)
3. Transducer Insertion Depth - should be performed according to the Wedge used and together with the Clamp Position Adjustment (Chapter 9)
4. Clamp Position Adjustment (Chapter 9)
5. Verticality Adjustment (Chapter 9)
6. Force Actuator Adjustment (Chapter 9)
7. Static Bonding Force Adjustment (Chapter 9)
8. Clamp Gap and Force Adjustment (Chapter 9)
9. Tail and Tear Solenoid Adjustments (Chapter 4)
10. Manual Z Adjustment (Chapter 9)
11. Clamp Sideways Position Adjustment (Chapter 9)
12. Ultrasonic Free Running Frequency Adjustment (Chapter 8)
13. Ultrasonic Power Adjustment (Chapter 8)
14. Bonding Parameters Setup (Chapter 4)

**ELECTRICAL SUBASSEMBLIES**

This chapter contains the information relevant for maintaining and adjusting the **K&S 4123 Wedge Bonder** electrical subassemblies, including:

- \* The Mother Board
- \* The Logic Board
- \* Temperature Controller (KTC)

Figure 8-1 is a schematic diagram of the electrical subassemblies and their interconnections.

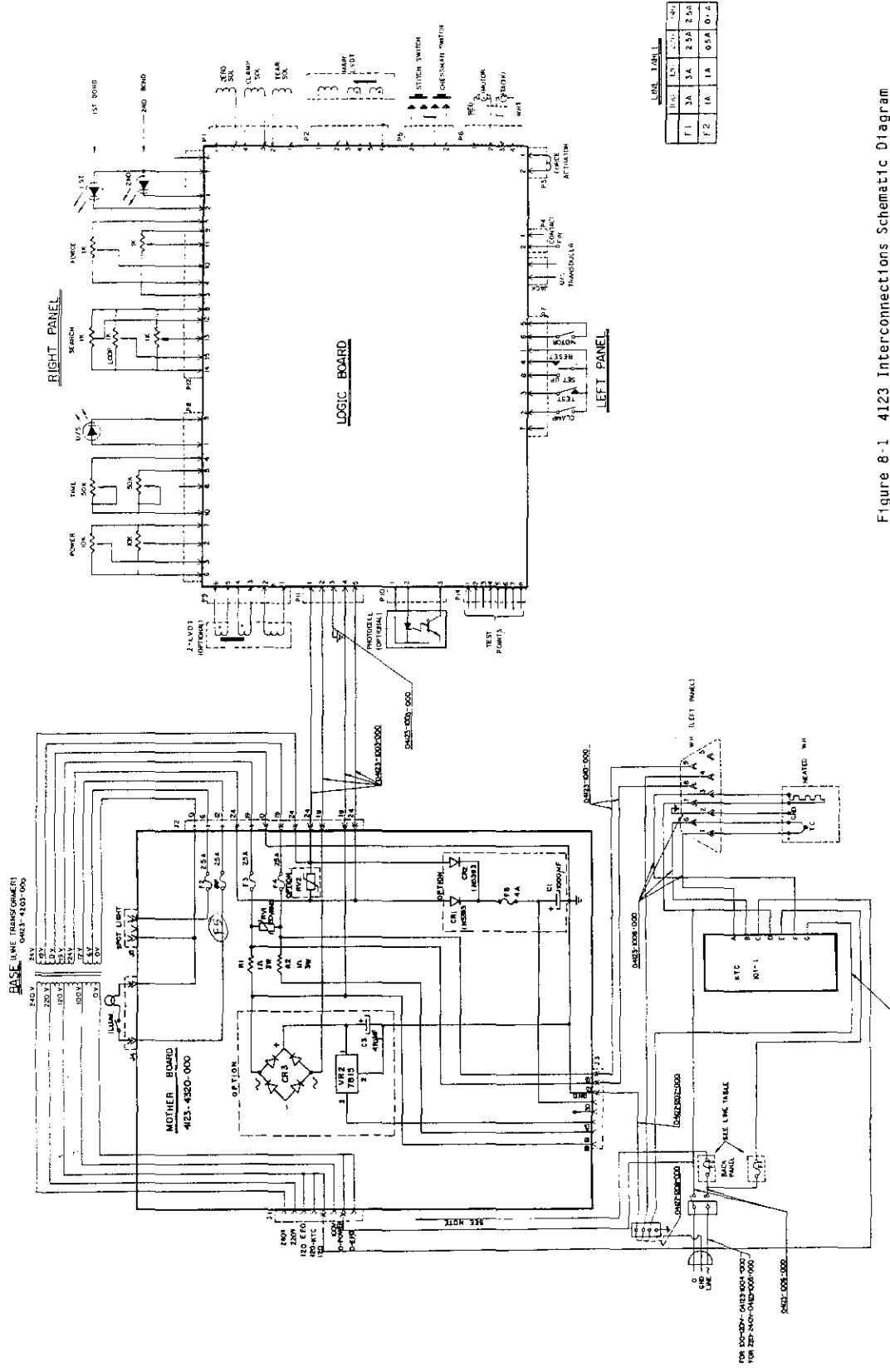

Figure 8-1 4123 Interconnections Schematic Diagram

K&S  
MODEL 4123 WEDGE BONDER

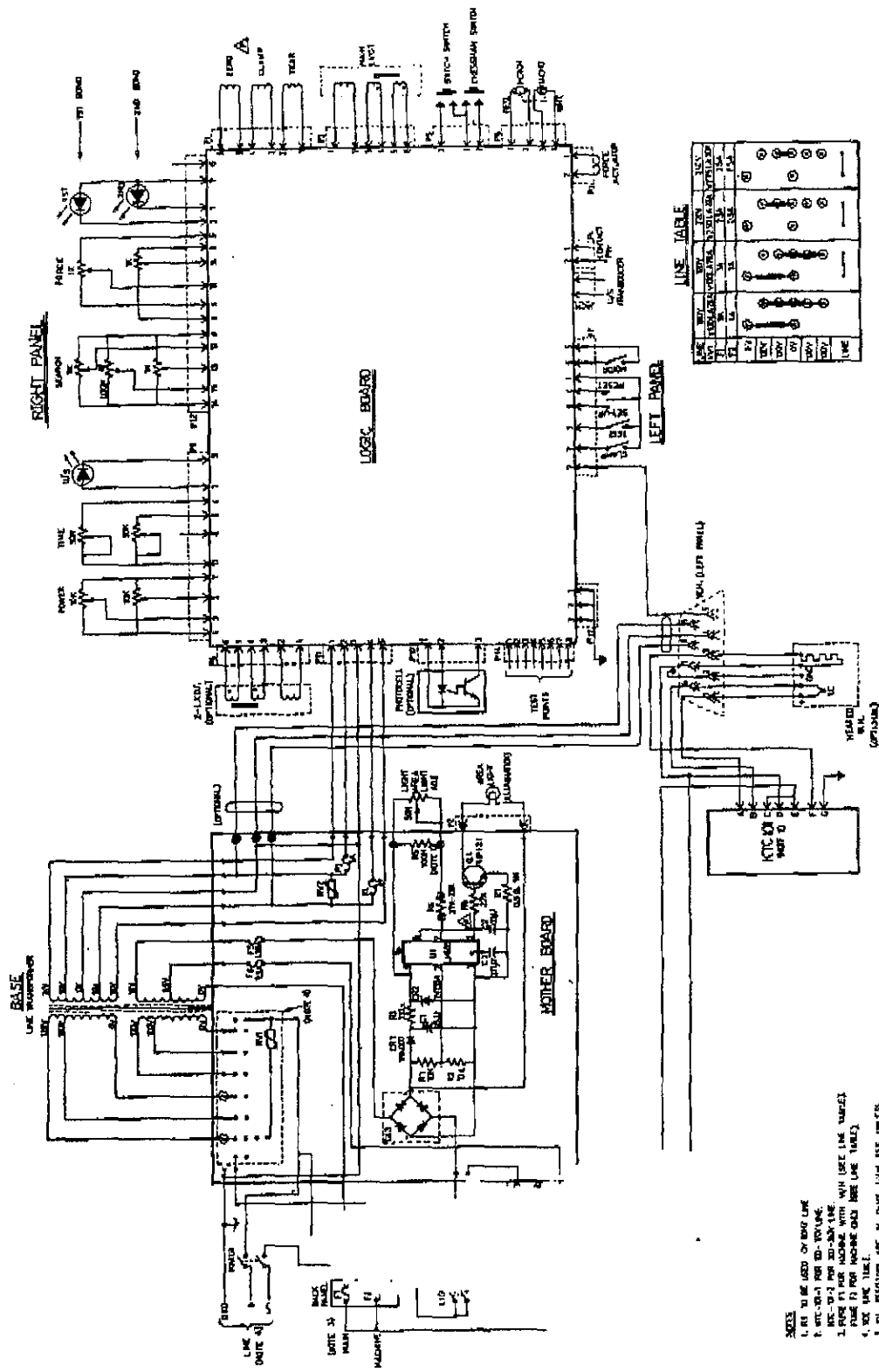

FIG. 11-7 INTERCONNECTIONS DIAGRAM AND MOTHER BOARD - SCHEMATIC DIAGRAM

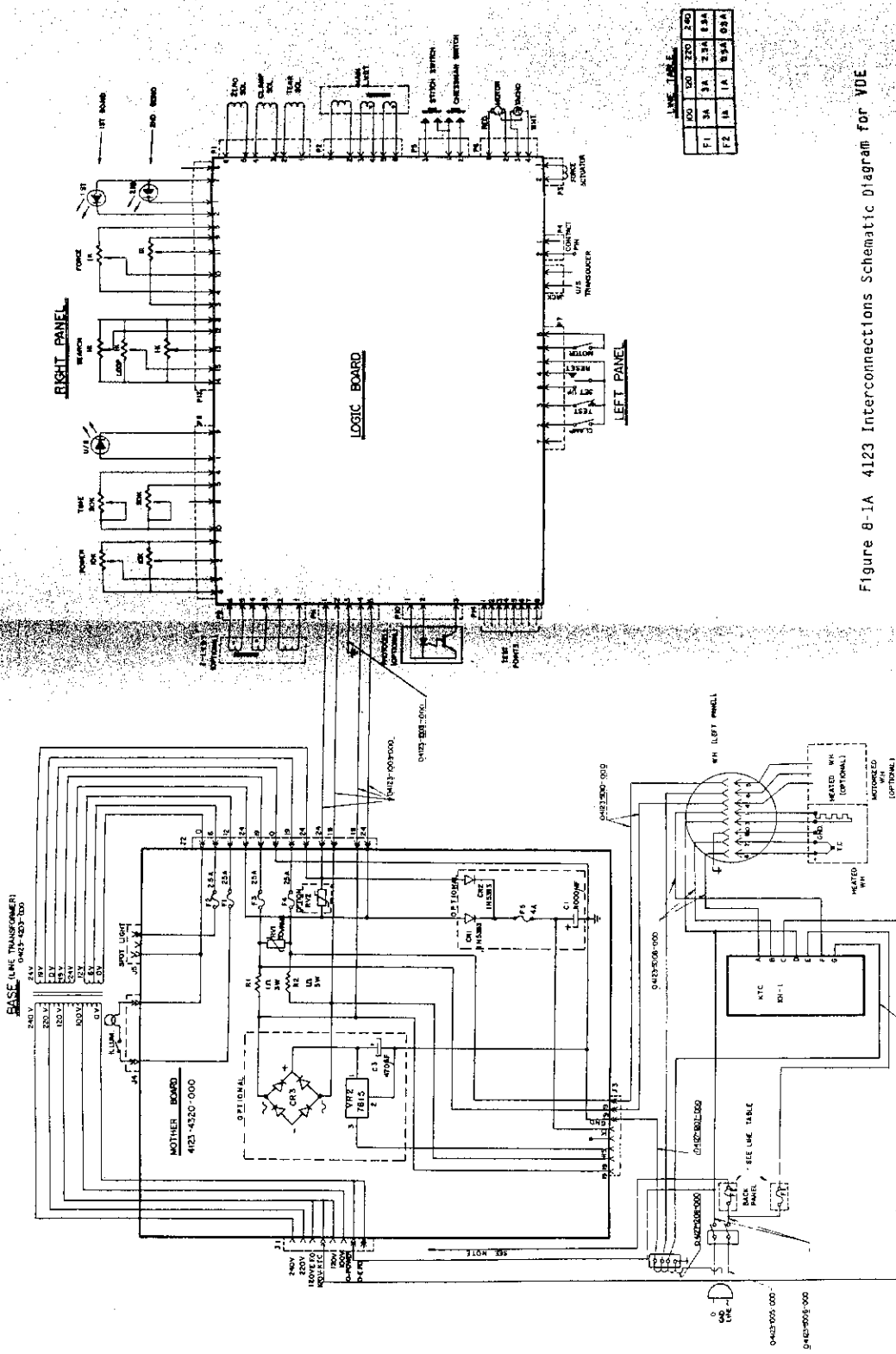

Figure 8-1A 4123 Interconnections Schematic Diagram for VDE

**4123 ELECTRICAL DESCRIPTION**

The following is an electrical description of the machine (refer to Figure 8-1 above).

**The Power Supply**

The 4123 can operate using 100V, 120V, 220V or 240V (50Hz or 60Hz). The machine is connected to the mains by a three-wire (active, neutral and ground) power cable. It is grounded by the grounding lead of the power cable attached to the base of the chassis. The two mains leads (active and neutral) are attached to the ON/OFF switch on the Left Control Panel.

The active power line is protected by two fuses, F1 and F2, located on the Back Panel. F1 protects the Workholder heater power supply and F2 protects the machine's operating power supply. The ratings for the two fuses are given in Table 8-1 (these ratings depend on the main voltage).

**Table 8-1 Main Power Fuse Ratings**

FUSE	100 Vac	120 Vac	220 Vac	240 Vac
F1	3A	3A	2.5A	2.5A
F2	1A	1A	0.5A	0.5A



The Mother Board

The Mother Board serves as the central connecting point for all power input to the 4123. It is mounted inside the Base on the righthand side.

The Mother Board has five connectors (J1-J5) that connect power to various subassemblies of the 4123.

The layout of the Mother Board is shown in Figure 8-2.

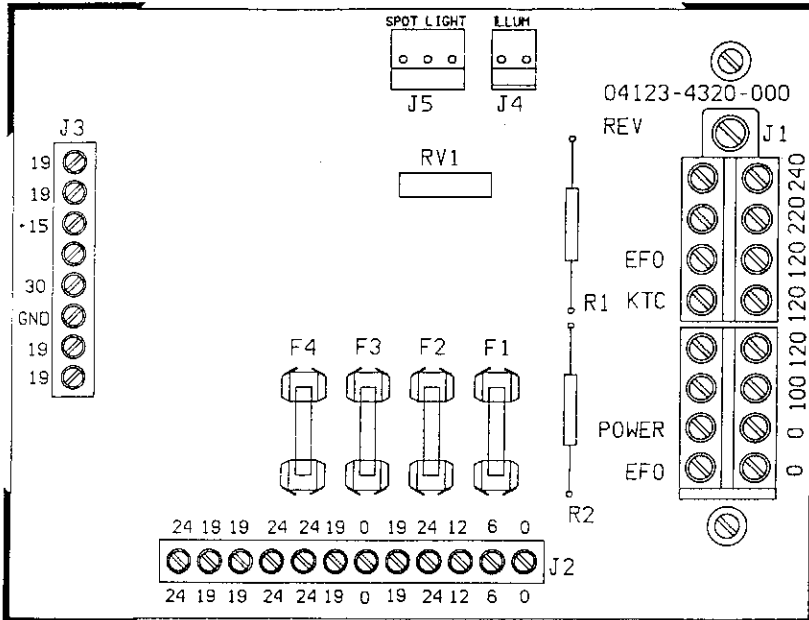

Figure 8-2 4123 Mother Board Layout

**Connector J1**

The input of connector J1 connects the mains power to a transformer. The primary of the transformer is tapped such that all incoming voltage supplies are converted to 120 Vac (the operating voltage of the Workholder Temperature Controller).

**Connector J2**

The transformer's secondary output is connected to connector J2. The secondary supplies the following operating voltages: 0, 6, 12, 19 and 24 Vac. These voltages are connected to the Spotlight (if present), illumination lamp, and Logic Board. The Logic Board receives the two 19 and two 24 Vac input voltages.

**Connector J3**

Connector J3 connects two 19 Vac lines to the Workholder connector on the Left Control Panel. The GND line is connected to the base of the machine chassis. The two other 19 Vac lines are spare. The +15 and +30 V lines are not currently used.

**Connector J4**

Connector J4 connects 12 Vac to the illumination lamp.

**Connector J5**

Connector J5 connects 6 Vac to the Spotlight (if present).

**Fuses**

There are four fuses mounted on the Mother Board. F1 protects the 12 Vac line to the illumination lamp. F2 protects the 6 Vac line to the Spotlight. F3 and F4 protect the two 19 Vac lines to the Logic Board. The four fuses are all 250V slowblow fuses rated for 2.5A.

### The Logic Board

The Logic Board contains all the electronic circuitry for controlling the operation of the 4123. The circuitry reads the input from the switches and dials of the control panels, and, together with the preset parameters, uses them to generate the electronic signals that operate the machine. The output sequence of these signals is timed to match the machine operating cycle.

The block diagram of the Logic Board is given in Figure 8-3. The detailed schematic of the board is given in Chapter 15.

#### The Logic Board Power Supply

The Logic Board receives two input voltages, 19Vac and 24Vac, from the Mother Board. These input voltages enter the Logic Board at P11.

#### Fuse F1

Fuse F1 is a 250V/0.630A Normal Blow fuse that protects the +34 Vdc voltage used internally by the Logic Board.

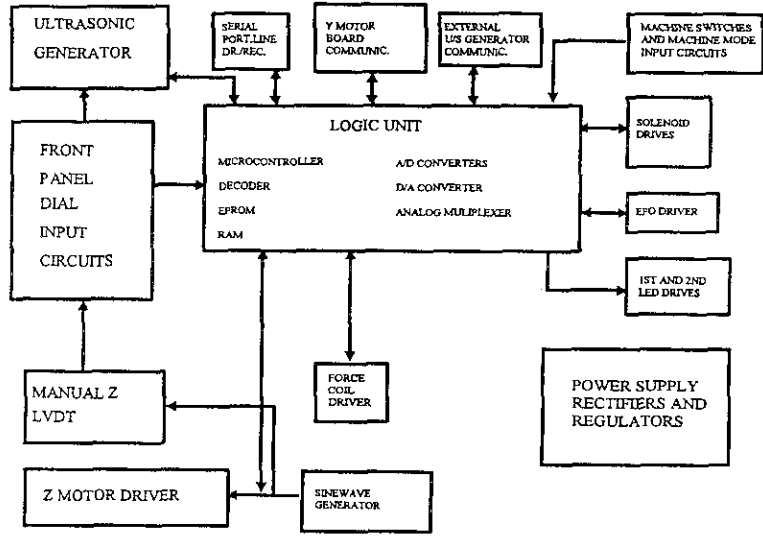

Figure 8-3 4123 Logic Board Block Diagram

### The Logic Unit

The Logic Unit provides all command and control of the K&S 4123 Wedge Bonder. It is based on a Motorola 68HC11 microcontroller.

There are two memory components in support of the microcontroller, a RAM and an EPROM.

### Sinewave Generator

The Sinewave generator drives the manual Z LVDT and Main Z LVDT. The generator is an oscillator with a fixed frequency of 2.7 kHz. Its amplitude must be 18 V<sub>ptp</sub>. This amplitude may be measured at TP4 (S.W.) and adjusted using the potentiometer RV1.

### Z Motor Mode

The Z Motor Mode circuit controls the Bonding Head armature up and down (Z axis) movement by activating the Z Motor. The Z Motor circuit has two operating modes: Chessman Mode and Manual Z Mode.

Pressing down on the Z Lever on the Right Control Panel sets the 4123 in the Manual Mode. When the Z Lever is pushed downward, its motion is sensed by the photocell and the Logic Board is set in the Manual Z Operating Mode. At the beginning of every cycle, the Logic Unit always checks if the machine is operating in the Chessman or Manual Z Mode.

### The Ultrasonic Generator Circuit

The Ultrasonic circuit drives the PZT crystals to produce the ultrasonic vibration required to bond the wire.

The generator is based on a Phase Lock Loop (PLL) integrated circuit. The free running frequency of the PLL is measured at TP1 (US.FR) and adjusted using the potentiometer RV6.

The circuit also contains a two-position switch, SW1, the setting of which influences the power. The positions are HIGH for high power, and LOW for low power. With the switch in the LOW position, the circuit voltage output can be adjusted by the trimmer RV7 and for the HIGH position the circuit voltage output can be adjusted by the trimmer RV8 Test Point TP2 (US Voltage).

When the machine is first powered up, or upon reset, the Logic Unit, as part of its diagnostic test routine, checks that the Transducer and Ultrasonic circuit form a closed circuit. If the diagnostic test detects an anomaly in the circuit, the Logic Unit provides the appropriate indication (see Table 11-1).

The circuit may also be tested manually by pressing the U/S TEST switch on the Left Control Panel. When this switch is pressed, the Ultrasonic circuit supplies a continuous signal to the Transducer. If the circuit is closed, the U/S LED on the Right Control Panel illuminates.

#### The Force Circuit

The Force circuit drives the Force Coil, which applies a force that is proportional to the current supplied.

When the SET-UP switch on the Left Control Panel is pressed, the circuit activates the Force Coil to apply the force value set in the upper FORCE dial while the Bonding Head is in the Reset position. During the time of the Loop position in the cycle, the circuit drives the Force Coil to the force value set in the lower FORCE dial.

#### Clamp and Tail Solenoid Circuits

The Logic Unit controls these circuits to drive the Clamp Solenoid and Tail (Zero) Solenoid in a Pulse Width Modulation mode.

When the CLAMP switch is placed in the On position, the Clamp Solenoid circuit keeps the solenoids in a fully energized state. In this state, the 4123 will not perform any bonding cycle. As a safety measure, if the CLAMP switch is left in the On position for more than 3 minutes, to keep the solenoids from burning out they are automatically de-energized. When the solenoid is fully de-energized, the 2nd LED on the Right Control Panel starts blinking. Normal operations can be reinitiated by placing the CLAMP switch in the Off position and pressing RESET.

#### NOTE

The solenoid will also enter the fully de-energized state if the 4123 is left in the Loop position for more than 3 minutes. If this happens, pressing RESET will return the 4123 to normal operations.

**Connectors**

Table 8-2 lists the connection points on the Logic Board for the 4123 and their functions. The physical location of each connector is shown in Figure 8-4.

**Table 8-2 Logic Board 4123 Connector Points**

CONNECTOR	FUNCTION
P1	Connects the Clamp, Tear and Tail Solenoids
P2	Connects the Main Z LVDT
P3	Connects the Force Actuator
P4	Connects the Contact Pin
P5	Connects the CHESSMAN and STITCH pushbuttons
P6	Connects the Z Motor
P7	Connects the switches on the Left Control Panel
P8	Connects the POWER and TIME dials and the U/S LED on the Right Control Panel
P9	Connects Manual Z LVDT

Table 8-2 Logic Board 4123 Connector Points  
(Continued)

CONNECTOR	FUNCTION
P10	Connects Manual Z Photocell
P11	Connects Power Supply
P12	Connects the SEARCH, FORCE and LOOP dials and the LEDs 1st and 2nd on the Right Control Panel
P14	OPTION. 3rd Ch. KIT
P20	For connecting an External Ultrasonic Generator
P23	Serial Communication Port
J1	Ultrasonic plug



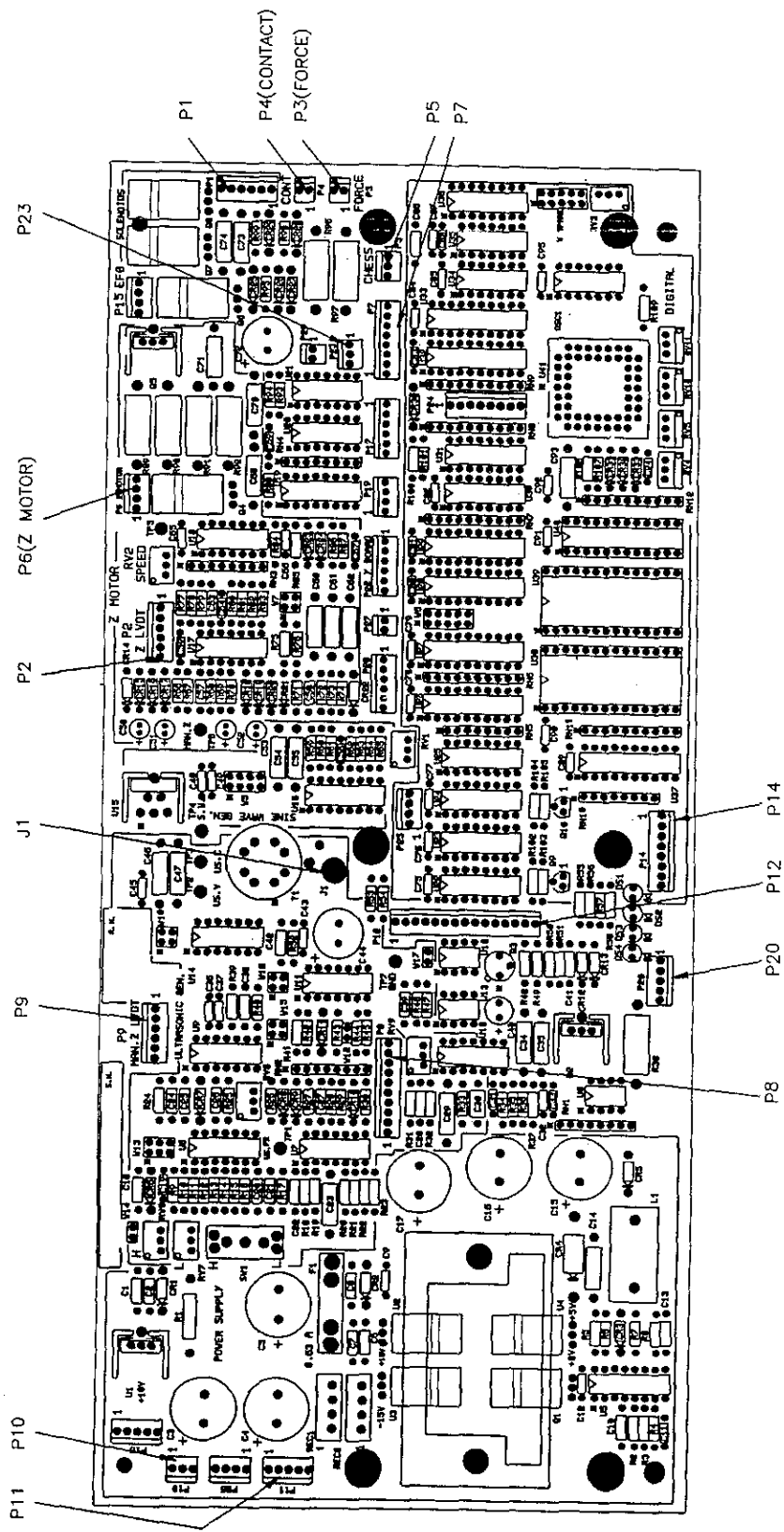

Figure 8-4 Logic Board Connection Points

## Logic Board Machine Adjustment Points

The Logic Board contains a number of adjustment points, these are summarized in Table 8-3. The physical locations of these are shown in Figure 8-5.

Table 8-3 Logic Board 4123 Adjustment Points

CONTROL	FUNCTION
SW1	Two-position switch for changing the power range of the ultrasonic generator (HIGH/LOW)
RV1	Trimmer for adjusting the Sine wave amplitude of the 18 V <sub>ptp</sub>
RV2	Trimmer for adjusting the speed of the Z Motor
RV3	Not Used
RV6	Trimmer for adjusting the ultrasonic free running frequency
RV7	Trimmer for adjusting the ultrasonic Low Scale voltage amplitude
RV8	Trimmer for adjusting the ultrasonic HIGH Scale voltage amplitude

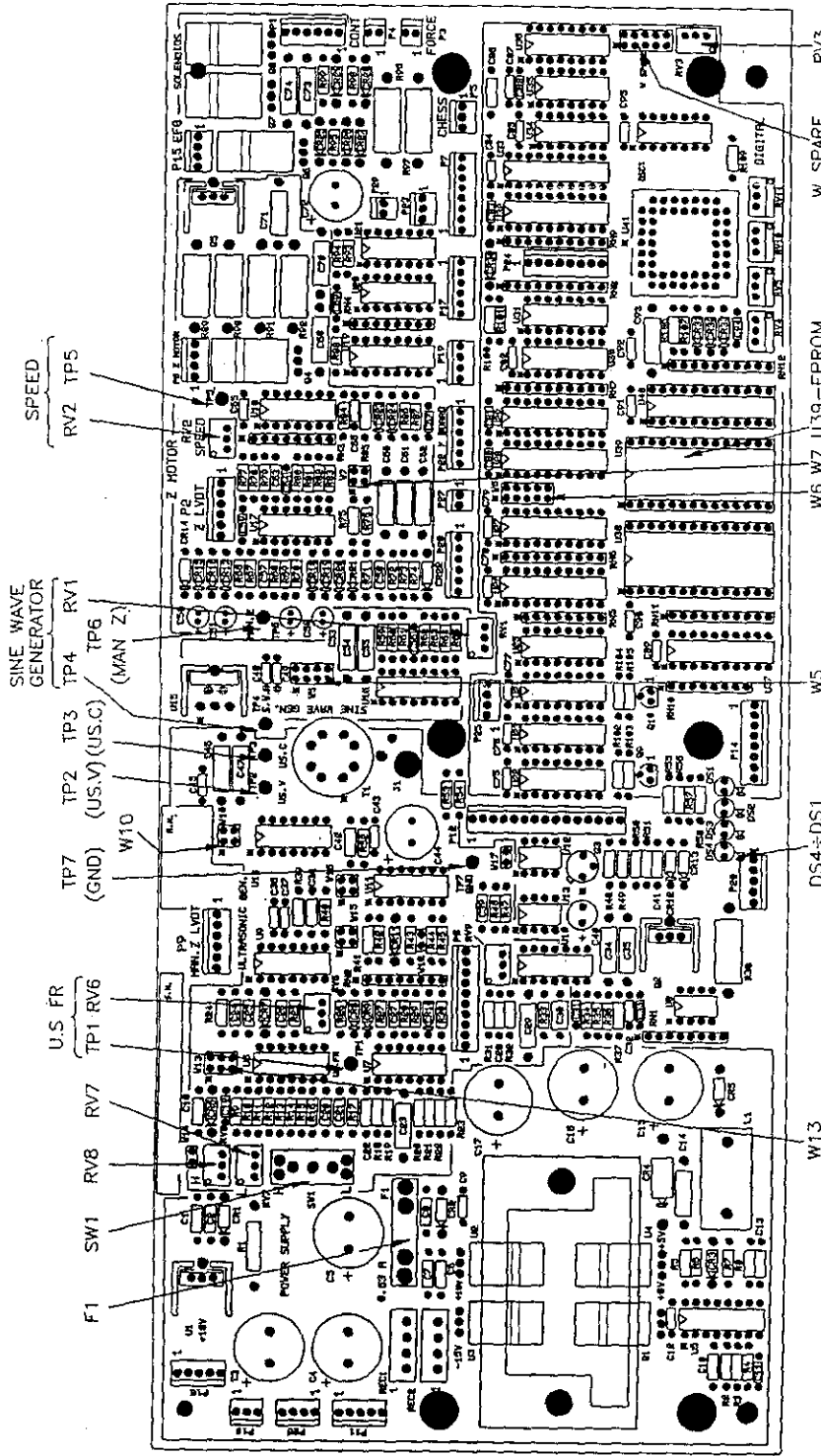

Figure 8-5 The 4125-4200-000 Logic Board

## Logic Board Test Points

The Logic Board provides test points for checking various signals of the board. These are summarized in Table 8-4. The locations of the test points are shown in Figure 8.5.

Table 8-4 Logic Board Test Points

TEST POINT	NAME	FUNCTION
TP1	US. FR	Ultrasonic free running frequency
TP2	US. V	Ultrasonic Generator output voltage
TP3	US. C	Ultrasonic Generator current sensing
TP4	S. W	Sinewave Generator output
TP5	SPEED	Z Motor Tacho Amplifier output
TP6	MAN. Z	Manual Z LVDT Amplifier output
TP7	GND.	Electrical Ground

Jumper Configuration

The Logic Board is designed for use in a number of K&S bonding machines. To match the Logic Board to a particular machine a specific jumper configuration is required. For the K&S 4123 Wedge Bonder, the jumper configuration is as shown below:

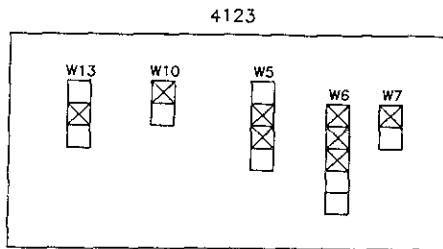

**External Ultrasonic Generator Connector**

Instead of using the Ultrasonic Generator that is mounted on the Logic Board, there is an optional External Ultrasonic Generator available. It is connected to the Logic Board via connector P20 on the board.

**BASE BACK COVER**

The following switches and indicators are accessed from the back of the Base:

- HIGH/LOW** This switch matches the ultrasonic power range to wire diameter:
- HIGH - for wire dia. from 2 up to 3 mil (50 - 75 micron)
  - LOW - for wire dia. from 0.5 up to 2 mil (12 - 50 micron)

**Diagnostic LEDs** Provide indications of the nature of faults detected during the self test or during the bonding cycle (see Chapter 11)

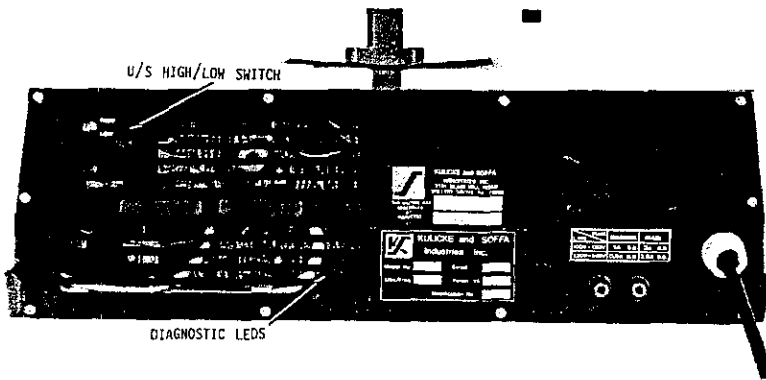

Figure 8-6 Base Back Cover

**TEMPERATURE CONTROLLER - KTC**

The KTC Temperature Controller serves to maintain the Workholder heater at the temperature set by the operator.

The schematic of the KTC is shown in Figure 8-8.

**Power Supply**

The Power Supply receives 120 Vac from the Mother Board. This it converts into a number of dc voltages that are used by various components of the KTC (as shown in Figure 8-8).

**Load Driver**

Its function is to supply power to the heating element. This power comes from the mains line. The circuit is protected by a 250V/4A fast blow fuse.



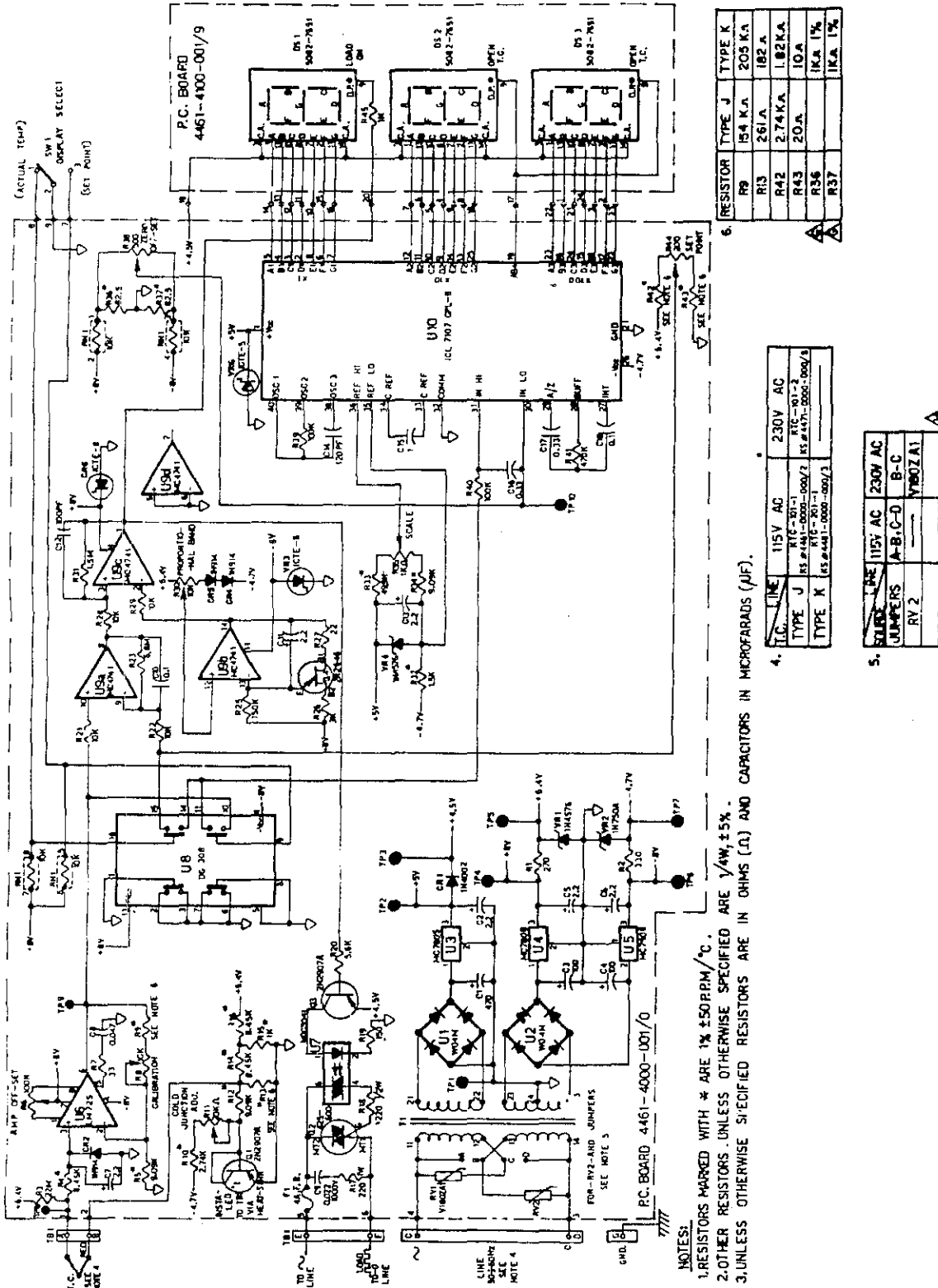

Figure 8-7 Temperature Controller Schematic

## ELECTRICAL ASSEMBLIES REPLACEMENT AND ADJUSTMENT

## Logic Board Replacement

Before replacing the Logic Board, check the new Logic Board and make sure that:

- \* The jumper configuration matches that given on page 8-17 above
- \* The program and version information that appears on the EPROM chip is correct for your machine

- Step 1      Position the main power switch to OFF.
- Step 2      Unplug all cables from the old Logic Board.
- Step 3      Unsnap the board from the six NYLATCH fasteners that hold the board.
- Step 4      Snap the new Logic Board in its place. Make sure that it is securely fastened by the six NYLATCH fasteners.
- Step 5      Plug in all the cables (check against Table 8-2 and Figure 8-4 above).
- Step 6      Turn on the machine and perform the following adjustments as needed:
  - a.    18 Vptp Adjustment (RV1)
  - b.    Ultrasonic Adjustment (RV6, RV7, RV8)
  - c.    Z Motor Speed Adjustment (RV2)

### Adjusting the 18Vptp

The 18 Vptp is used by the Logic Board in determining travel distance of the Bonding Head between the Reset position and the Overtravel position.

#### Required Tools:

Oscilloscope (or Digital Multimeter)  
Small screwdriver  
Regular screwdriver

Before performing this procedure, the machine should be on and a warmup period of at least 30 minutes has elapsed.

- Step 1      Make sure that the Bonding Head is in the Reset position, ensure that the 1st indicator on the Right Control Panel is illuminated.
- Step 2      Remove the back cover, and connect the oscilloscope (or multimeter) probe to pin TP4 (S.W.) and the ground to pin TP7 (GND) (see Figure 8-4). Check that you have a sharp, nondistorted sine wave on the oscilloscope of 18Vptp (or 6.37Vrms if using a multimeter).
- Step 3      If the voltage does not have the value given in Step 2, adjust the voltage to this value with the trimmer RV1 on the Logic Board (see Figure 8-5).
- Step 4      After adjusting the 18Vptp, adjust the Reset position, verticality and Force Actuator according to procedures given in Chapter 9.

## Ultrasonic Generator Adjustment

### Required Tools:

Digital Frequency Counter  
Oscilloscope  
Small Flathead screwdriver

### Free Running Frequency Adjustment

For this procedure you will need the digital frequency counter and small flathead screwdriver.

- Step 1      Unplug the Transducer from the Logic Board (connection point J1, see Figure 8-4).
- Step 2      Connect the counter leads to TP1 (US. FR) and TP7 (GND) (see Figure 8-5).
- Step 3      Turn on the bonding machine and allow a warm-up period of 30 minutes.
- Step 4      Check that the value displayed by the counter matches 58.5 KHz. If it does not, use the small screwdriver to adjust trimmer potentiometer RV6 until you get the proper value.
- Step 5      Disconnect the digital frequency counter.

### Ultrasonic Power Adjustment

For this procedure you will need the oscilloscope and small screwdriver.

- Step 1 Turn the bonding machine off and verify that the Transducer is disconnected.
- Step 2 Set switch SW1 (see Figure 8-5) to LOW.
- Step 3 Move the jumper in W13 to the bottom position (see Figure below).
- Step 4 Connect the oscilloscope probe to TP2 (US. V) and the ground to TP7 (GND).
- Step 5 Turn on the bonding machine and wait for it to complete its initialization routines (only the 1st LED indicator is illuminated). Then press down and hold the TEST switch on the front panel. At the same time, adjust the oscilloscope time base and voltage scale until you get a waveform like that shown below.

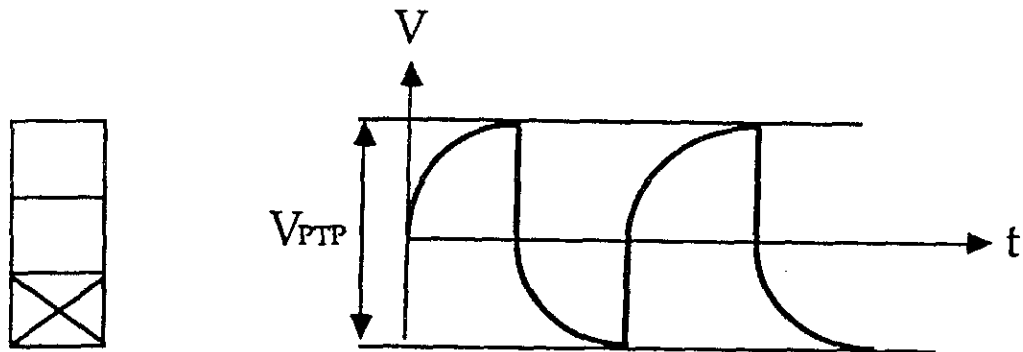

W13 Jumper Setting

Waveform

- Step 6 Adjust trimmer RV7 on the Logic Board until you get the voltage value of 16 V<sub>PTP</sub>.

- Step 7 Turn the bonding machine off. Set switch SW1 to HIGH.  
Then repeat Step 5.
- Step 8 Adjust trimmer RV8 on the Logic Board until you get the voltage value of 40 VPTP.
- Step 9 Turn the bonding machine off. Disconnect the oscilloscope probes.  
Place the jumper in W13 back in its original setting.
- Step 10 Insert the Transducer plug into its place.
- Step 11 Set switch SW1 to LOW (or leave it in HIGH, depending on the power requirements for your application).
- Step 12 Power on the machine and wait for it to complete its initialization routines.  
  
Check that no Diagnostic LEDs are illuminated.  
  
Verify that the Ultrasonic Generator is operating properly by pressing down the TEST switch and checking that the U/S LED indicator illuminates.
- Step 13 Replace and secure the bonding machine Base covers and back cover.

### Z Motor Speed Adjustment

The Bonding Head movement speed was set at the factory to the optimum speed for the 4123 machine.

If it is necessary to change the factory-set speed: insert a screwdriver in trimmer RV2 (see Figure 8-5). A clockwise turn increases the Z Motor speed, counter-clockwise decreases it.

**MECHANICAL SUBASSEMBLIES**

This chapter contains details of the main mechanical subassemblies of the **K&S 4123 Wedge Bonder**. Along with the mechanical description, the chapter also provides procedures for adjusting and replacing mechanical parts of the machine.

**NOTE**

In the maintenance procedures, where necessary, reference is made to the appropriate Drawing Number and Item on the drawing. These appear in square brackets. If in doubt as to the identity of a part, refer to the referenced drawing (found in Chapter 15).

The **K&S Wedge Bonder** can be broken down into two major mechanical assemblies:

- \* Main Head Assembly
- \* Base Assembly

**MAIN HEAD ASSEMBLY**

The Main Head assembly contains the mechanisms for transporting the wire to the bonding surface, performing the bonding and tearing the wire after bonding. In addition the Main Head serves as the platform for attaching the Microscope and Area Illumination Lamp (as well as the optional Spotlight when it is installed).

Left and right views of the Main Head assembly are shown in Figures 9-1 and 9-2, respectively.



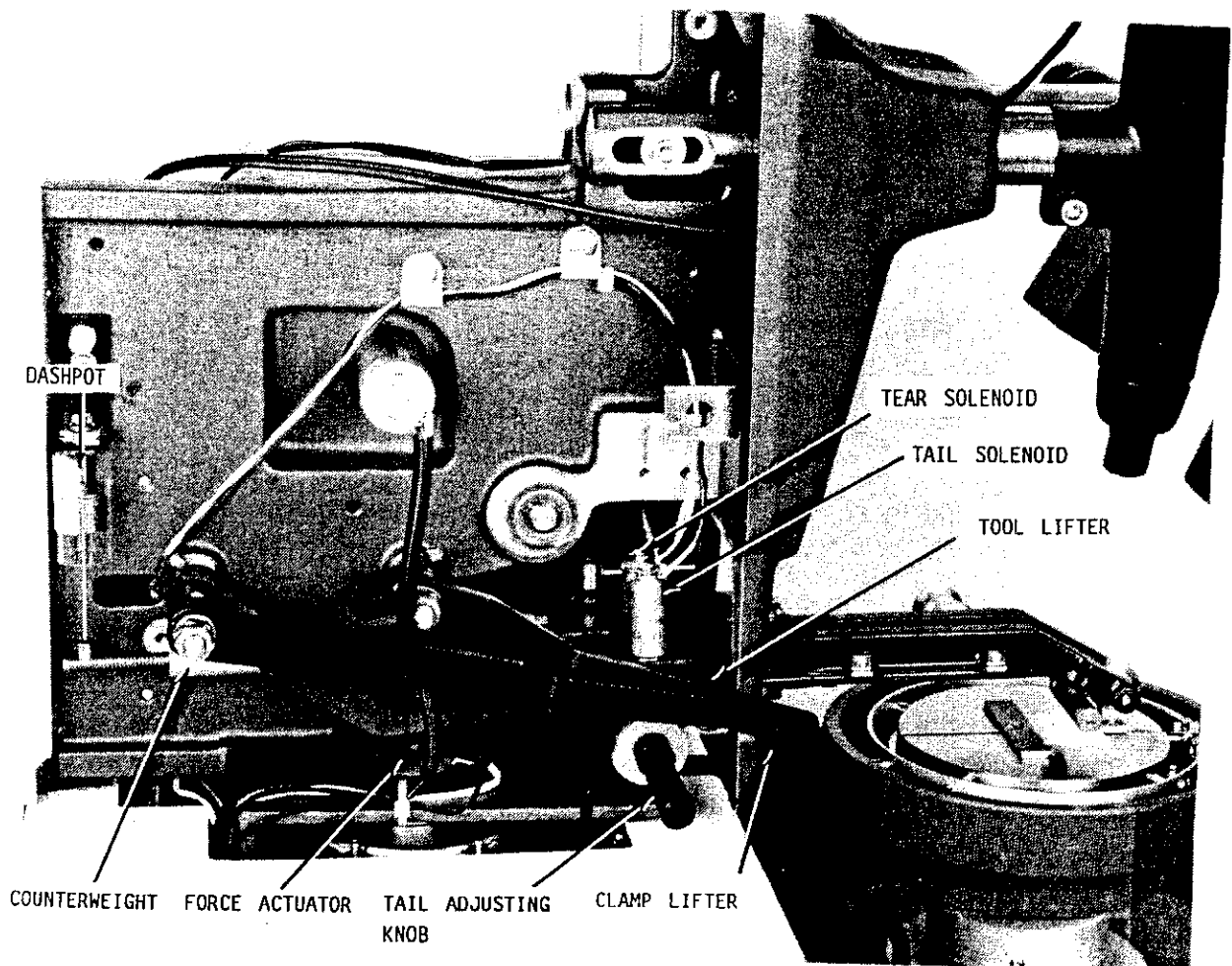

Figure 9-1 Main Head - Left View

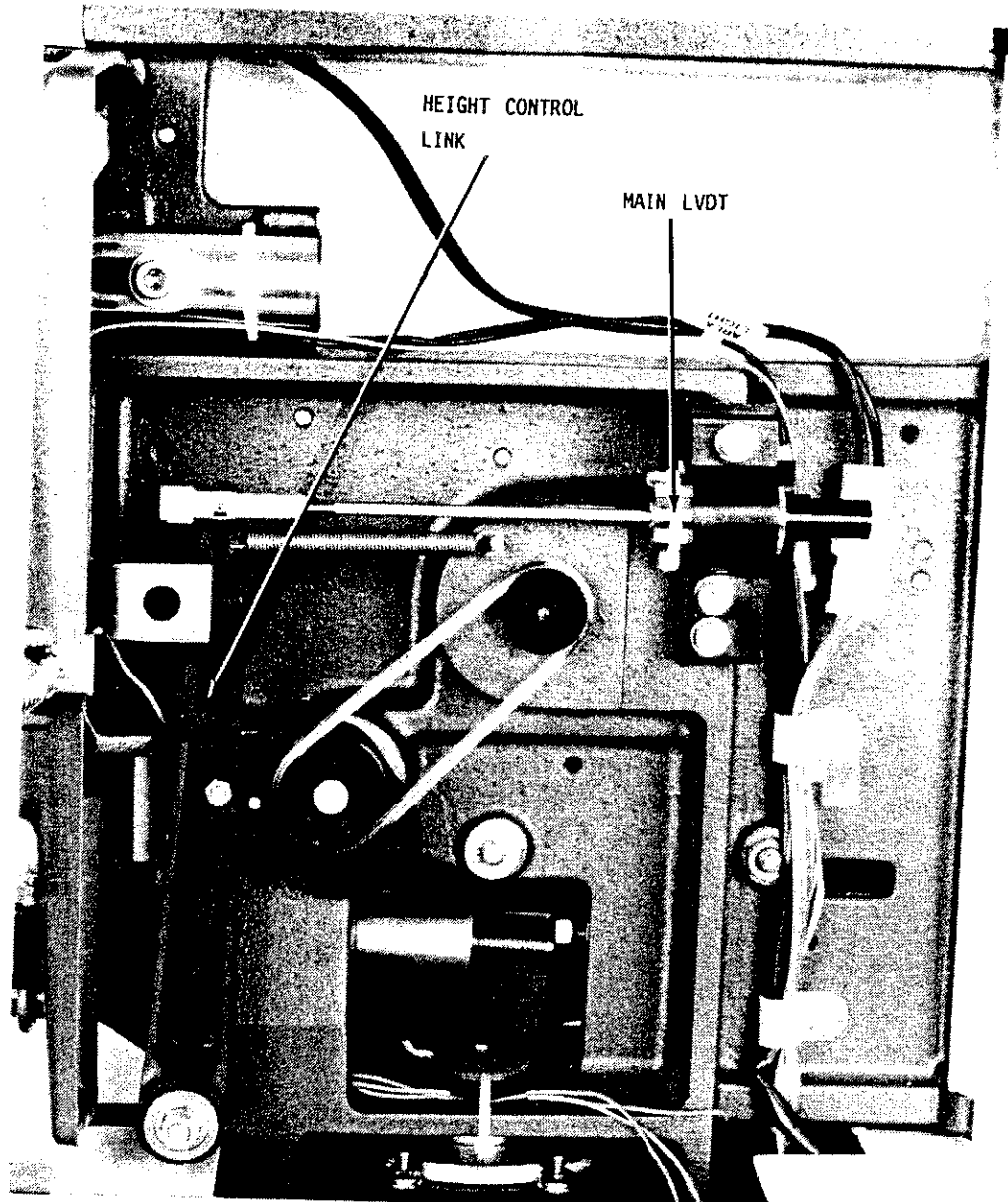

Figure 9-2 Main Head - Right View

### **Bonding Head Drive Mechanism** (Refer to Figure 9-3)

The Bonding Head (1) mechanism moves the Wedge tip to preset positions and applies mechanical forces, in response to electronic signals from the Logic Board.

The Bonding Head pivot (A) is fixed on the Main Head casting. The Ultrasonic Transducer (4) which holds the Wedge is clamped to the front end of the Bonding Head armature. The Wedge Z motion (up and down) is produced by the Bonding Head rocking on its pivot.

The applied bond force is a combination of the static balance and the electronically controlled force. Static balance is adjusted by changing the position of the Counterweights (12,15) which are threaded on rods connected to the Bonding Head.

#### **The Force Actuator**

The Force Actuator (13) is an electrical moving coil mounted with their axis vertical between the poles of a permanent magnet. When the coil is energized, it rises, pushing up the back (Heel Ball) of the Bonding Head armature, thereby lowering the Wedge at the front of the armature, and applying a controlled force.

The actuator has four force levels (i.e., the force at which the coil rises): constant force, tracking force, first bond force and second bond force - all applied at the appropriate time in the bonding cycle. The first bond and second bond forces are applied while the Wedge is sitting on the bond. They are fixed by the settings the FORCE dials on the Right Control Panel.

Tracking force and constant force are set at the factory. The tracking force overcomes the Air Dashpot incidental braking action during descent of the Bonding Head to the Search position and keeps the Levelling Screw in contact with the Contact Pin.

The constant force keeps the actuator coil in continuous contact with the Heel Ball. This force is weak enough to be overcome by the Link Return Spring. When the POWER switch is OFF, the actuator coil drops away from the Heel Ball.

**The Air Dashpot**

The Air Dashpot (11) is an adjustable pneumatic shock absorber that dampens any possible vertical vibrations of the Bonding Head. It absorbs most of the impact created when the Wedge makes contact with the bonding surface. Adjustment of the amount of damping is done by rotating the needle valve screw in the top of the Dashpot.

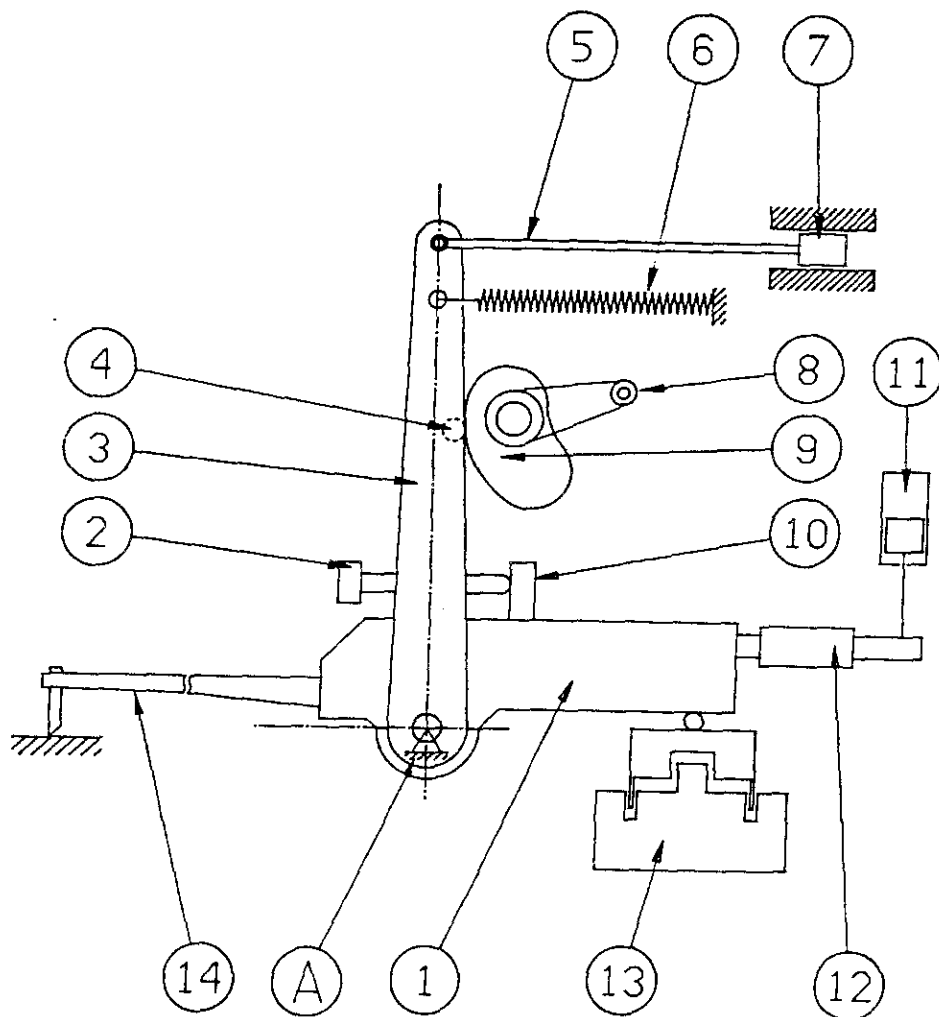

**Figure 9-3 The Bonding Head Mechanism**

### Height Control Link and Contact Mechanism

The Height Control Link (3) is pivoted independently at its lower end on the Bonding Head pivot and held back against the Height Control Cam by the Link Return Spring. After each bond, the actuator force is switched to the constant force, allowing the Link Return Spring (6) to pull back the Height Control Link as controlled by the Height Control Cam.

Associated with the Height Control Link are two electro-mechanical devices that serve to supply positional information of the Bonding Head to the Logic Board, upon which the machine controls the motion of the Bonding Head. These are:

\* Contact Pin

The Contact Pin (10) mechanism maintains electrical contact between the Bonding Head and the Height Control Link until the descending Wedge is stopped by the bonding surface. The Height Control Cam continues revolving to the Overtravel position, tilting the Height Control Link forward independently of the Bonding Head.

When the first bond is complete, the Logic Board reduces actuator force to the constant force and reverses the Z Motor. This permits the Link Return Spring to tilt back the Height Control Link and bring the Leveling Screw back in contact with the Contact Pin. Restoration of the contact circuit energizes the Tail Solenoid.

\* Linear Variable Differential Transformer (LVDT)

The LVDT (7) feeds back Height Control Link position signals to the Logic Board. The Logic Board uses these signals to synchronize the bonding cycle and to modulate the bonding speed accordingly.

### Z Motor

The Z Motor is a dc servo motor that, on signal from the Logic Board, drives the Height Control Cam (9) through a reduction gear and a belt-drive mechanism. The Height Control Cam engages the Cam Follower (4) on the Height Control Link, thus regulating its tilt forward or backward. A built-in tachometer on the Z Motor feeds back motor speed signals to the Logic Board, which uses these signals to modulate the Bonding Head speed.

### Tool Lifter

The Tool Lifter (see Figure 9-1) enables the operator to raise the front end of the Bonding Head manually for threading wire, replacing Wedge, or protecting the Wedge when not in use. Raising the Tool Lifter handle causes its cam to engage and lower the rear of the Bonding Head lever, causing the Wedge to rise. The Wedge will remain in the raised position until the Tool Lifter handle is lowered.

### Clamp Lifter

The Clamp Lifter enables the operator to move the Clamp from the back of the Wedge in order to thread the wire into the Wedge wire feed hole. The Clamp Lifter handle is linked to an arm which raises the rear end of the Tear & Feed Bracket.

**BONDING HEAD MAINTENANCE**

One of the most important actions of the 4123 is the movement of the Bonding Head. The Bonding Head subassembly is installed in the Main Head in such a manner as to afford smooth, unbroken motion without any jerking or friction.

**Bonding Head Motion**

The Bonding Head motion during a bonding cycle is described in Chapter 6. The stages of the motion are denoted by the final position of the Bonding Head for the given stage. These stages are: Reset, 1st Search, 1st Bond, Loop, 2nd Search, 2nd Bond.

In order to check that the motion of the Bonding Head is as it should be:

**NOTE**

This procedure should always be performed after any adjustment made to the Static Force.

- Step 1 Turn off the machine. Then manually set the Bonding Head to the Bond Position by pushing the Height Control Link.
- Step 2 Raise the Bonding Head and let it fall freely. It should drop with a steady, smooth motion back to the Bond Position.
- Step 3 Grasp the Bonding Head armature and try to move it sideways. If you feel any sideways backlash, adjustment or replacement of the bearings is required.

Improper Bonding Head motion, i.e., the movement of the Bonding Head arm is jumpy or the arm does not move at all, may be caused from one or a combination of the following:

- \* A problem with the Dashpot
- \* The Bearing Screw is too tight
- \* The Angular Contact Flange Bearing is faulty

### Replacing the Flange Bearings

In order to replace the Flange Bearings, the Bonding Head assembly must be removed from the Main Head. To accomplish this:

#### NOTE

For ease of performing this procedure, it is suggested that you remove the Front Cover from the Main Head. In order to do this, you have to first remove the Microscope Bracket and the Spotlight (if installed), then remove the two screws that hold the cover to the Main Head.

- Step 1 Cut the plastic SnapTite tie band [dwg 4123-405-000 Item (W)] that holds the cable bundle.
- Step 2 Disconnect all electrical cables that connect the Bonding Head to the Logic Board.
- Step 3 Disconnect the Dashpot from the threaded rod at the back of the Bonding Head. Tape the Dashpot Rod to the side of the Main Head casting in order to keep it from falling out.
- Step 4 Remove the two locking nuts [dwg 4123-405-000 Item (O)] and put them aside.
- Step 5 Loosen the locking nut [dwg 4124-410-000 Item (19)] all the way to the left using a 7/16" wrench.
- Step 6 Using a 5/32" wrench, loosen screw [dwg 4124-410-000 Item (13)] all the way to the right.
- Step 7 Gently remove the Bonding Head. Make sure that all cables have been disconnected so that all the wires that come out with the Bonding Head are disconnected.



- Step 8 At this point, check the angular contact Flange Bearings [dwg 4123-450-000 Item (N)] by spinning it in its socket. Check also the ball seats [dwg 4124-410-000 Item (O)]. Always check the bearings on both sides, and if you have to replace one, replace both of them (this assures even wear).
- Step 9 Remove the faulty bearing. Some degree of force will be required since the bearings are glued in place with Loctite.
- Step 10 Clean out any Loctite residue from the bearing housing and then clean the housing with a cleaning agent.
- Step 11 Using a cotton swab, smear a thin layer of Loctite 601 on the bearing well and insert the new bearing. Take care that no Loctite gets into the bearing.

**NOTE**

In the event that the bearing does not slide into its place easily, give it a light tap so that it is well seated. Make sure that you are not putting the bearing in crookedly.

Wait 30 minutes for the Loctite to dry before proceeding with this procedure.

- Step 12 Check that the movement of the new bearing is smooth.
- Step 13 Slide the Bonding Head back into place and reconnect all wires, then screw in the retaining screw [dwg 4124-410-000 Item 13] and tighten down the locking nut [dwg 4124-410-000 Item 19].
- Step 14 Perform Bonding Head Bearings Adjustment.

**Bonding Head Bearings Adjustment**

- Step 1 Using a 5/32" wrench, very gently tighten the retaining screw [dwg 4124-410-000 Item (13)]. Lift the Bonding Head and let it fall a few times. It should move freely up and down without any sideways backlash. If you detect any sideways play in the Bonding Head, further tighten the retaining screw.
- Step 2 Secure the retaining screw by tightening the nut [dwg 4124-410-000 Item (19)]. Make sure that the screw does not rotate and that the Bonding Head still moves freely with no sideways backlash.
- Step 3 Replace the two nuts [dwg 4123-405-000 Item (0)]. Tighten the first nut and check that the Height Control Link has no sideways play and that it tilts freely. Then secure the first nut with the second nut.
- Step 4 Connect the Dashpot Rod to the back of the threaded rod that comes out of the Bonding Head.

### Adjusting Static Bonding Force and Dashpot

This adjustment is required only when changing to a bonding wire of different diameter. Thicker wires require greater force. The total force applied to the bond is the static force, applied by two adjustable counterweights on the Bonding Head, plus the dynamic force applied by the Force Actuator (the Air Dashpot damping effect is only incidental).

In some cases where high bonding force is required, one or two of the counterweights may be removed.

- Step 1 Turn the machine off.
- Step 2 Place the force gauge under the Wedge and adjust static force by rotating first the front counterweight then the rear one [dwg 4123-450-000] to obtain an undamped force of 15 grams on the Bonding Head, suitable for a 1 mil (25 microns) wire. Lock counterweight nuts.
- Step 3 Raise the front end of the Bonding Head and allow it to fall. The Wedge tip should fall smoothly.
- Step 4 If necessary, adjust the bleeder valve [dwg 4123-405-000 Item (A)] to obtain the desired damping effect, which gives an even but not too slow drop of the Bonding Head when raised by hand.

### Replacement of Dashpot

Generally the Dashpot needs to be replaced whenever there is a problem with the lowering of the Bonding Head, that is, whenever either the Bonding Head does not go down at all or its downward movement is seriously impeded.

Before replacing the Dashpot make sure that the cause is not due to faulty adjustment, excess pressure on the pivot, or a faulty bearing [dwg 4123-450-000 Item (C)].

- Step 1 Using a 7/32" wrench, release the Dashpot rod [dwg 4123-405-000 Item (A)] from the Airpot Connection Rod [dwg 4123-450-000 Item (2)]. Exercise care that the Dashpot piston does not fall out.
- Step 2 Using a 1/2" wrench, remove the nut holding the Dashpot to the Dashpot Support [dwg 4123-410-000] and remove the Dashpot.
- Step 3 Check the Dashpot linkage by inverting the Dashpot and holding it at about a 45<sup>o</sup>, the Rod should fall inside the Dashpot of its own weight. If it does not, this is a sign that there are severe frictional forces in the linkage or within the Dashpot and the Dashpot assembly must be replaced.
- Step 4 While holding the piston inside the Dashpot, slip the new Dashpot assembly into the Dashpot Support. Secure the Dashpot in place by tightening the nut with the 1/2" wrench.
- Step 5 Connect the lower end of the piston to the Airpot Connecting Rod.
- Step 6 Cycle the 4123 through a bonding cycle and check that the Bonding Head moves as required.

**FORCE ACTUATOR ASSEMBLY**

[dwg 4124-410-000]

The Force Actuator may require replacement and/or cleaning and adjustment in the following cases:

- \* Dust and/or debris has accumulated in the magnet groove causing friction or causing the Force Coil to stick.
- \* A break in the coil windings.

**Force Actuator Checkout**

- Step 1 With the power turned off and the door on the right side of the Main Head open, with your fingers move the Height Control Link forward and lift the Force Coil. It should lift up smoothly and fall by itself when released.
- Step 2 Turn the machine on and leave it in the Reset position. With your finger press down on the Force Coil. It should move down easily and, when released, rise by itself until it makes contact with the Heel Ball of the Bonding Head armature.
- Step 3 Refer to the Diagnostic Indicators (see Chapter 11) and check that the Force Coil circuit is not open. If an open circuit is indicated, unplug the Force Coil from the Logic Board and measure the resistance of the coil. It should be in the range of 7.5 Ohm. If not, replace the coil.

**Force Actuator Disassembly**

- Step 1 With the machine turned off, disconnect the tie cable [dwg 4123-417-000 Item (M)] attaching the Force Actuator to the Main Head [dwg 4123-405-000].
- Step 2 Unscrew the five screws of the Rear Panel and remove the left base cover. Do not completely remove the cover so as not to damage the Chessman harness.
- Step 3 Disconnect the coil plug from connector P3 on the Logic Board (see Figure 8-4).

- Step 4 Remove the two screws [dwg 4124-410-000 Item (T)] from the Main Head casting [dwg 4123-417-000 Item (18)] and remove the whole Force Actuator [dwg 4124-410-000 Item (11)] assembly.
- Step 5 Once the Force Actuator has been taken out, it is possible to check that the coil moves freely, and to remove the coil in case it is necessary to clean the magnet groove of dust or debris.
- The way to remove the debris is to insert sticky tape into the groove and pull it out. Dust can be removed using an air gun, or by vacuum.
- Step 6 If required, replace the coil. After replacing, verify free movement of the coil within the magnet, without friction or obstruction.
- Step 7 If the magnet seems defective or weak, replace it as well.

#### Force Actuator Replacement

- Step 1 Position the Force Actuator by moving it backward or forward until the ball bearing [dwg 4123-450-000 Item (P)] is in the center of the coil. Adjust the Force Actuator height, so that in the Reset position the distance between the ball bearing and the coil is approximately 0.08" (2 mm). Then, tighten the screws.
- Step 2 Using the SnapTite cable tie attach the coil wires [dwg 4123-405-000 Item (W)] to the Main Head casting [dwg 4124-410-000 Item (18)]. Verify that the wires are not too taut, so that the coil can move freely.
- Step 3 Connect the coil connector to P3 on the Logic Board (see Figure 8-4).

**Adjusting the Force Actuator Assembly****NOTE**

Throughout this procedure, make sure that the Heel Ball remains in the center of the coil.

- Step 1 With the machine on, ensure that it is in the Reset position, 1st indicator on the Right Control Panel illuminated.
- Step 2 Loosen the two screws that hold the Force Actuator to the Main Head casting.
- Step 3 Move the Force Actuator up (or down) such that a play of 0.04" to 0.12" (1-3 mm) between the coil and the Heel Ball is created when the coil is pressed downward (ensure that the coil recovers to its original position when released).
- Step 4 Retighten the two retaining screws holding the Force Actuator to the Main Head casting.

**MAIN LVDT RESET POSITION ADJUSTMENT**

The LVDT is located in the right side of the Main Head. It establishes the starting position of the Cam relative to the Height Control Link. This position is required in order that all Bonding Head positions (Reset, Search, Overtravel, etc.) can be accurately tracked during the bonding cycle. The LVDT should be replaced or adjusted if it feeds back faulty position readings to the Logic Board. This procedure is always performed after adjusting the 18V<sub>ptp</sub> on the Logic Board (see Chapter 8).

**Required tools:**

3/16" wrench  
5/16" wrench

- Step 1 Ensure that the Bonding Head is in the Reset position, 1st indicator on the Right Control Panel illuminated.
- Step 2 On the Left Control Panel, set the MOTOR switch to ON.
- Step 3 Using the two wrenches, release the locking nut [dwg 4123-405-000 Item (12)] on the Rod End. Turn the Push Rod [dwg 4123-405-000 Item (5)] until the indentation on the Cam is in line with the Cam Follower on the Height Control Link.

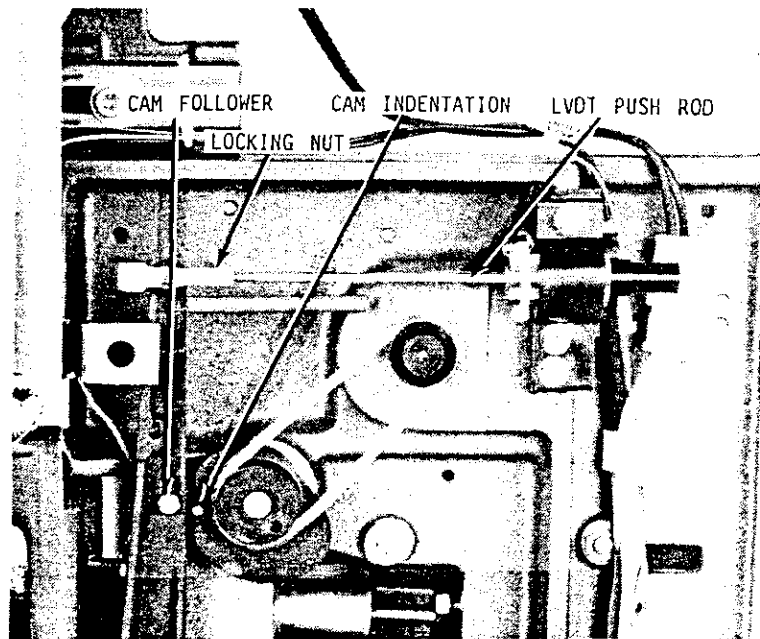

Figure 9-4 Push Rod Adjustment



- Step 4 Using the two wrenches, tighten the locking nut on the Rod End.
- Step 5 Cycle the machine as follows: Press and release CHESSMAN pushbutton twice to run the machine through a single cycle. The 1st LED on the Right Control Panel should illuminate at the end of cycle, with the Z Motor in the Reset position.
- Step 6 After performing LVDT adjustments, check and adjust Bonding Head verticality against the appropriate steps of the procedure for Transducer Leveling that follows.

**TRANSDUCER REPLACEMENT AND LEVELING**

The Ultrasonic Transducer converts electrical signals from the Logic Board to mechanical vibrations at a frequency of about 60 kHz by means of two piezo electric crystals.

**CAUTION**

The Ultrasonic Transducer is a very sensitive electro-mechanical device. Do not attempt to disassembly the Transducer. This requires special calibration equipment and knowhow.

The Transducer may have to be replaced in the following cases:

- \* The Diagnostic Indicators indicate that the Transducer is faulty.
- \* The bonding quality is inconsistent or poor.

**Required tools:**

Square Block  
3" Verticality Pin 0.0625" diameter  
90° Angle Bar with a leg length of at least 3"  
Open and Allen Wrenches  
Torque Meter

**NOTE**

The Square Block, Verticality Pin and Angle Bar are available from K&S: Maintenance Kit, P/N 4123-0910-000.

- Step 1 Turn the machine off.
- Step 2 Remove present Transducer as follows:
- a. Unplug the Transducer cable from J1 on the Logic Board (Figure 8-4).
  - b. Cut the plastic strips that bind the Transducer cable to the other wiring.
  - c. Loosen the 2 lock nuts of the Transducer clamp's U-bolt and remove Transducer.

- Step 3 Insert the cylindrical end of the replacement Transducer into the U-bolt, tighten lock nuts somewhat, lead the Transducer cable back to the U/S jack on the Logic Board, and plug it in. Secure the cable with the rest of the machine wiring with plastic strips (leave enough wire slack to allow the Bonding Head to move freely).
- Step 4 Install a Wedge in the Transducer according to the Setup Gauge. Adjust the insertion depth of the Transducer in the U-bolt so that the clamp is 0.02" (0.5mm) behind the Wedge, and 0.02" (0.5mm) above the tip of the Wedge. If you cannot achieve these dimensions, adjust the Wire Clamp position according to Steps 3 through 5 of the Clamp Solenoid Replacement procedure that follows this procedure.
- Step 5 Insert the Verticality Pin into the Transducer and clamp it in place with the set screw at the tip of the Transducer (see Figure 9-5).
- Step 6 While holding the Transducer at the correct insertion depth, adjust its angular orientation by turning it with your finger tips (Figure 9-6). The verticality pin should line up with an angle bar on a square block. Tighten the 2 U-bolt lock nuts at a 7 kg-cm torque.
- Step 7 Set POWER and MOTOR switches to ON, and bring the Bonding Head to the LOOP position by pressing and releasing the CHESSMAN pushbutton (check that the 2nd indicator on the Right Control Panel is illuminated).
- Step 8 Set LOOP dial to 0. When Bonding Head is at the LOOP=0 position, the Height Control Link should be vertical.

- Step 9 To level the Transducer, view it from the side against an angle bar on square block (Figure 9-5). Loosen the lock nut on the levelling screw of the Height Control Link. Adjust the levelling screw so that when it touches the Contact Pin of the Bonding Head, the verticality pin lines up with the angle bar. Loosen the Wedge set screw and remove the verticality pin from the Transducer. Make sure that the ground connection is kept tight under the nut on the levelling screw.
- Step 10 Insert the Wedge into the Transducer according to the procedure given in Chapter 4 (Wedge Installation). Checkout the Transducer by pressing TEST on the Left Control Panel, the U/S indicator on the Right Control Panel should illuminate. Now perform Force Actuator Adjustment procedure, as given above in this chapter.

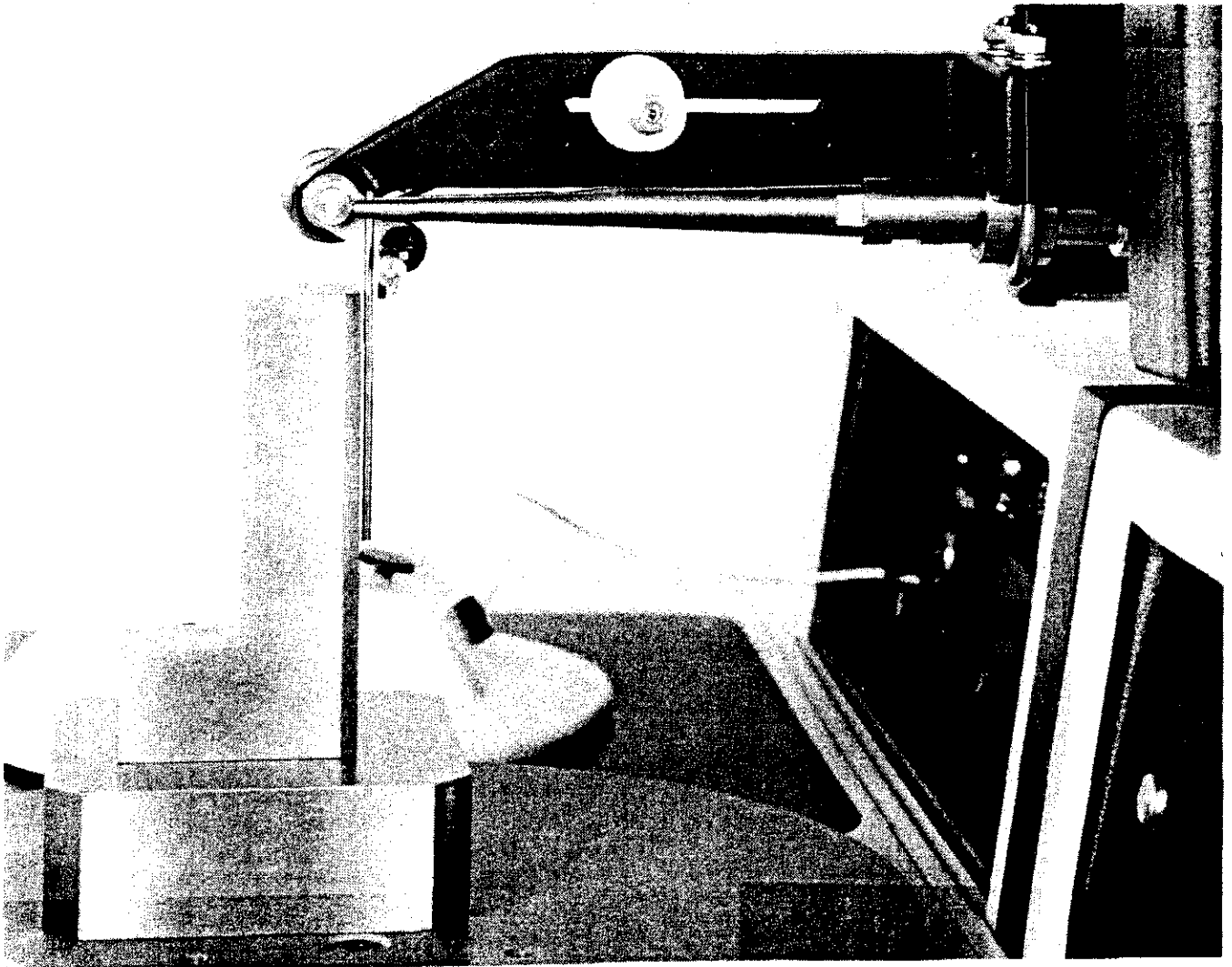

Figure 9-5 Verticality Adjustment - Side View

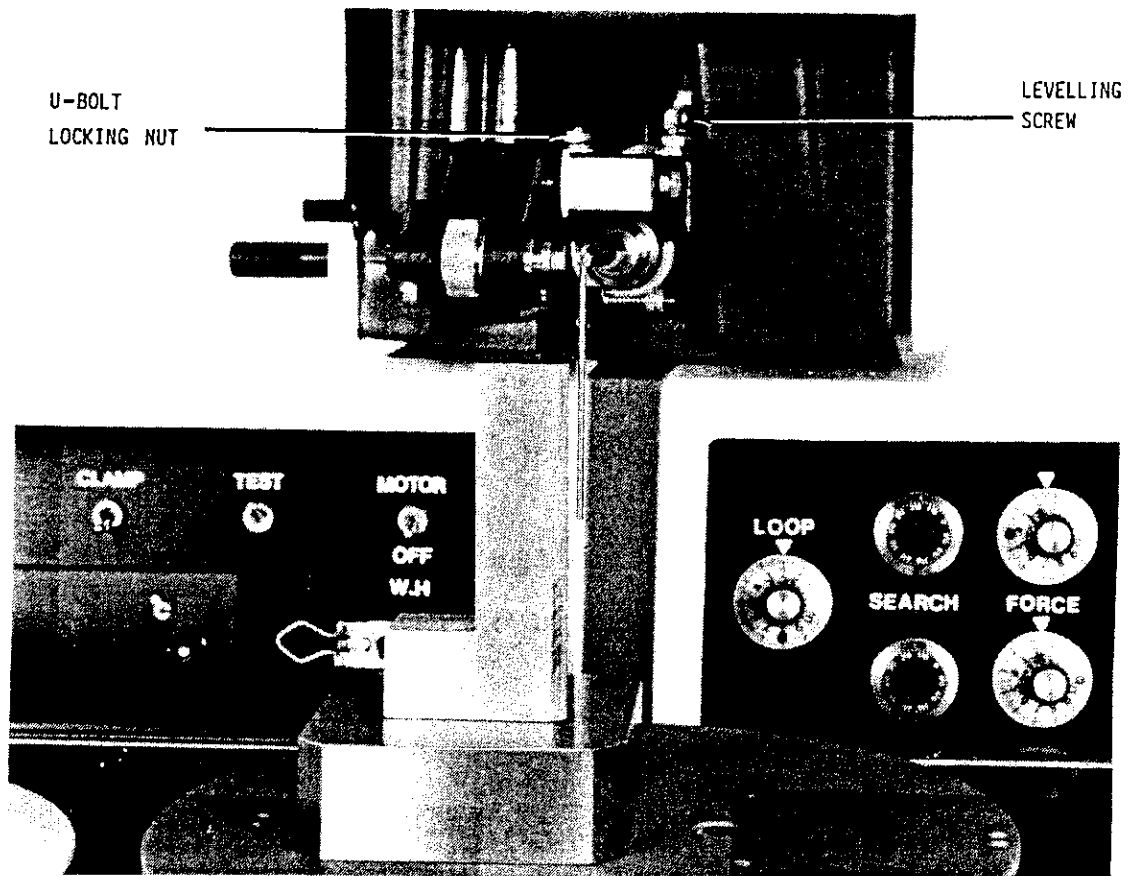

Figure 9-6 Verticality Adjustment - Front View

**CLAMP SOLENOID, WIRE CLAMP REPLACEMENT AND ADJUSTMENT**

The Clamp Solenoid (Figure 9-7) opens the Wire Clamp against the opposing force of a compressed spring. The solenoid is mounted on the Bonding Head casting behind the Wedge. The clamp gap must be readjusted when replacing a solenoid or on clamp malfunction. The clamping force must be adjusted whenever you change to bonding wire of a different diameter.

**Required tools:**

Force Gauge 0-100 grams  
Feeler Gauge  
Open and Allen wrenches

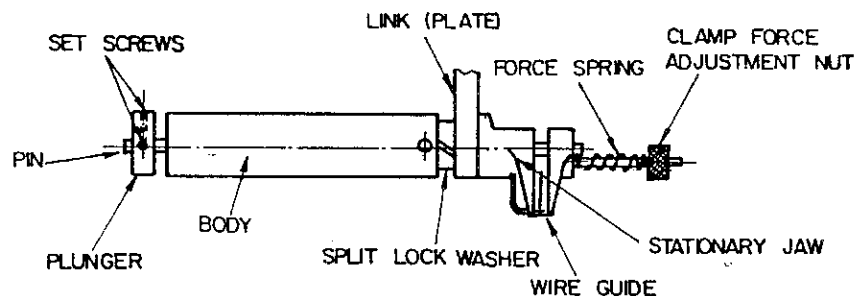

**Figure 9-7 Clamp Solenoid and Wire Clamp**

If the Wire Clamp cannot be opened, the Wire Clamp or the Clamp Solenoid must be cleaned, adjusted or replaced.

A Clamp Solenoid check is required whenever Clamp Solenoid fault indications appear in the Diagnostic Indicators (see Chapter 11).

The clamping force should be set to 100 gr with a clamp opening gap of 0.003" to 0.005" (0.075 to 0.127 mm). If the clamping force is too high or the clamp gap is too wide, there is a risk that the Clamp Solenoid will not be able to overcome the clamping force spring.

Before replacing the solenoid, check that the Clamp Solenoid is firmly connected to the Logic Board and is receiving voltage. If the connection is all right, check that the resistance of the Clamp Solenoid is 60 Ohms  $\pm 5\%$ . If the resistance measurement indicates an open circuit, or a short circuit, then the Clamp Solenoid must be replaced.

### Clamp Solenoid Replacement

- Step 1 Disconnect the Clamp Solenoid harness from connector P1 on the Logic Board (see Figure 8-4). Remove the harness from all clamps holding it to the Bonding Head.
- Step 2 Using a wrench, unscrew the Wire Clamp from the Clamp Solenoid. Grasp the Wire Clamp on the stationary jaw (see Figure 9-7). Carefully remove the Wire Clamp and split lock washer.
- Step 3 Install the new Clamp Solenoid and adjust the position of the Wire Clamp relative to the Wedge. Make sure that the Wedge is installed in the Transducer according to the Setup Gauge, then thread wire into the Wedge wire feed hole.
- Step 4 Release the screw that secures the Clamp Link to the Tear and Feed Bracket pivot (see Figure 9-8). Adjust the position of the Clamp until the Clamp is 0.02" (0.5mm) from the Wedge and 0.02" (0.5mm) above the Wedge tip. This adjustment can be done by turning the Wire Clamp and Clamp Link until the required distances from the Wedge are achieved.

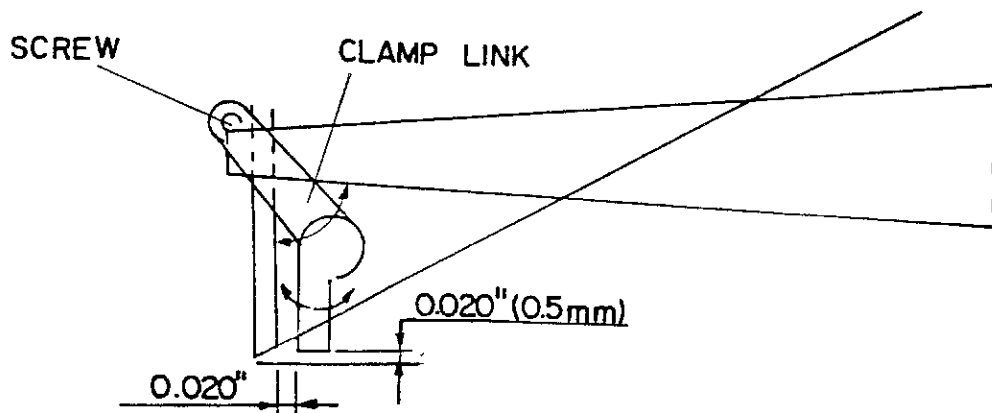

Figure 9-8 Wire Clamp Position



- Step 5 After adjusting the Clamp position, lock the clamp in its position by turning the Clamp Solenoid and locking the Clamp Link. Thread the wire through the Wire Guide and then through the Clamp jaws. Check that the wire is properly clamped in the Wire Clamp.
- Step 6 Reconnect the Clamp Solenoid harness to connector P1 on the Logic Board and secure the harness to the Bonding Head. Make sure that you leave sufficient slack so that the harness does not interfere with the Bonding Head movement (otherwise the static balance of the Bonding Head may be improper leading to inconsistencies in the bonding).

#### NOTE

If the Clamp position interferes with gaining access and you need to increase the distance between the Clamp and the Wedge, readjust its position as given above. However, be aware that if the distance between the Clamp and the Wedge is too great, tail length accuracy may be affected.

#### Clamp Solenoid Gap Adjustment

- Step 1 Turn the machine on and check that the 1st indicator on the Right Control Panel is illuminated.
- Step 2 Loosen the two set screws that secure the solenoid plunger to the pin (see Figure 9-7).
- Step 3 Press on the pin to the right and insert a feeler gauge between the clamp jaws. Set the clamp gap to between 0.003" and 0.005" (75-127 microns).
- Step 4 Toggle the CLAMP switch on the Left Control Panel to the up position. Note that the solenoid plunger is pulled towards the solenoid body. With your finger, press lightly on the solenoid pin until you feel it make contact with the clamp pin. Then tighten the two set screws on the plunger. Remove the feeler gauge.
- Step 5 Turn Clamp Solenoid off by toggling the CLAMP switch to the down position.

- Step 6 Press the force gauge against the left end of the Clamp Solenoid pin and read the force required to open the clamp.
- Step 7 Adjust the clamping force by turning the two clamp force adjustment nuts (Figure 9-7). Set the clamping force so that the wire will just tear when pulled (approximately 100 grams for a gap of 0.005" [127 microns]).
- Step 8 Test that the clamp opens and closes properly by toggling the CLAMP switch on the Left Control Panel up and down several times.
- Step 9 Rotate the solenoid plunger in steps of 90° and check that the clamp opens at each position. If it does not, the plunger is probably not parallel to the Clamp Solenoid face.

**Clamp Lateral Position Adjustment**

The wire path must be in a straight line from the Transducer hole to the Wedge wire feed hole. The Wire Clamp serves as a guide in leading the wire from the Wedge feed hole to the Wedge foot. If the Clamp is not aligned along the same axis as the Wedge feed hole, the wire will not be centered under the foot of the Wedge. This leads to bonding inconsistencies.

- Step 1 Thread the wire through the Clamp jaws and the Wedge feed hole. Focus the microscope on the tip of the Wedge and check if the wire is in the center of the Wedge. If it is, exit procedure at this point.
- Step 2 Loosen the set screw (see Figure 9-9). Adjust the lateral position of the Clamp by turning the knurled adjusting nut until the wire is centered under the Wedge foot.

**NOTE**

There are two set screws on the knurled adjusting nut. Only the set screw that faces you, as you look at the adjusting nut, need be loosened.

- Step 3 Make a few bonds and then check that the wire is still centered. Readjust, if necessary.
- Step 4 Secure the knurled adjusting nut by tightening the set screw (do not over tighten as this may strip the set screw threads).

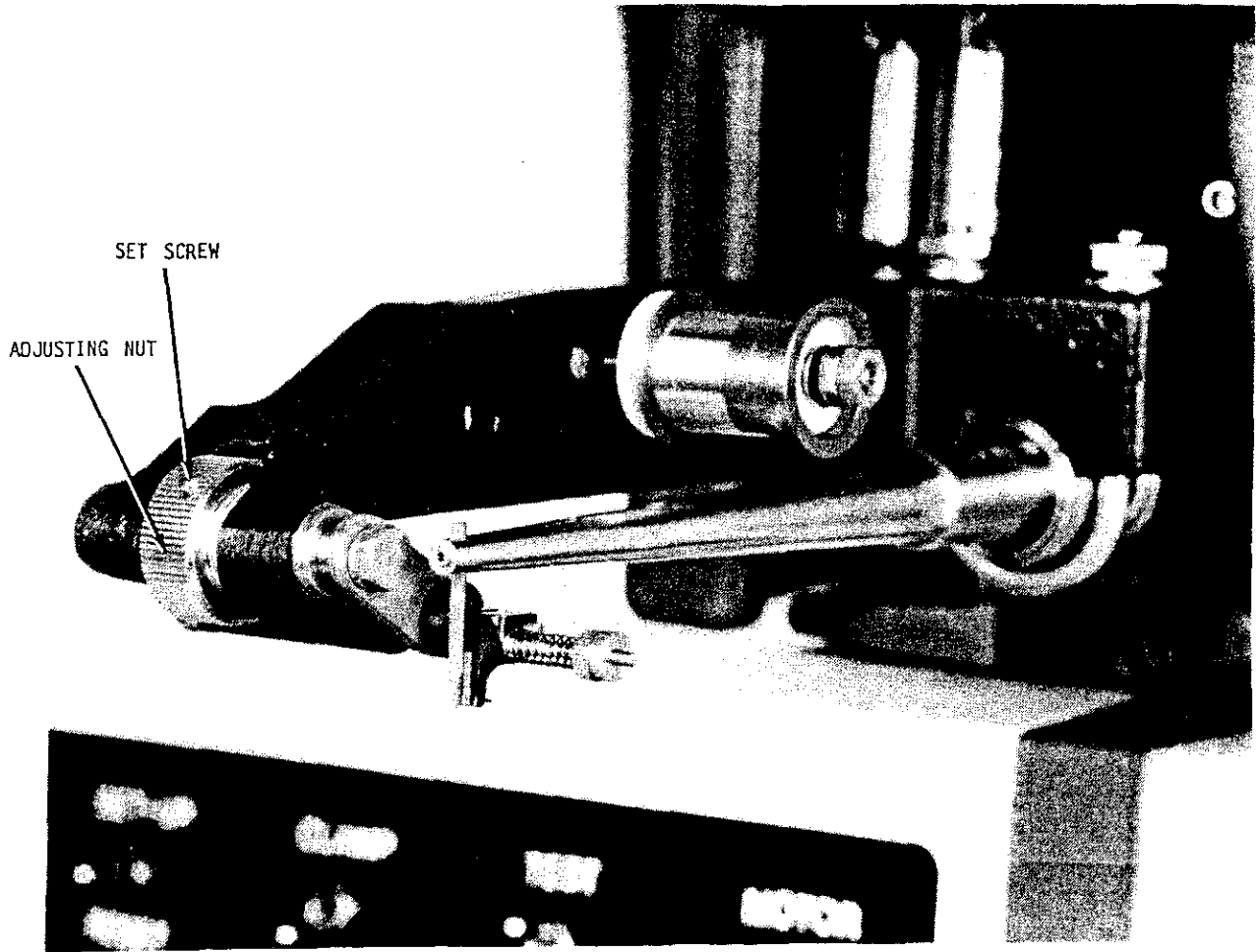

Figure 9-9 Wire Clamp Lateral Position Adjustment

**Wire Tension Adjustment - 0.5" Spool Holder**

The wire tension depends directly on the friction of the Spool Holder bearings.

To increase the friction, and thereby the tension, tighten the two nuts [dwg 4123-0426-000 Item (E)] against the spring washers.

To decrease the friction, and thereby the tension, loosen the two nuts [dwg 4123-0426-000 Item (E)] against the spring washers.

**THE TEAR AND FEED BRACKET**

(Refer to dwg 4123-0450-000)

The Tear and Feed Bracket [dwg 4123-0450-000 Item (12)] is pivoted at the front end of the Bonding Head armature. The pivot is glued to the bracket on one side, and the Wire Clamp is secured to the pivot by means of a screw [dwg 4123-0450-000 Item (D)].

The Tear and Tail Solenoids are mounted on the bracket. The solenoid plungers rest on the adjustable cams that are mounted on the Bonding Head armature. When one of the solenoids is energized, the solenoid body is pulled up, relative to the plunger, and the Tear and Feed Bracket pivots, resulting in moving the Clamp away from the Wedge. When both solenoids are de-energized, the Tear and Feed Bracket rests on the eccentric cam [dwg 4123-0450-000 Item (5)].

Parts that may need servicing or replacement are the Tear Solenoid and the Tail Solenoid.

### Tear Solenoid/Tail Solenoid Replacement

The Solenoids have to be replaced if they are out of electrical tolerance (due, for example, to short or open circuits in the solenoids). A faulty solenoid is indicated by an improper resistance measurement of the solenoid:

The Tear Solenoid resistance should be between 151.5 Ohms and 167.5 Ohms.

The Tail Solenoid resistance should be between 42 Ohms and 46.5 Ohms.

#### NOTE

If you replace one or both solenoids, you have to readjust the eccentric cam [dwg 4123-0450-000 Item (5)] such that when the Tail Adjusting knob is set for the initial position, the solenoid plunger rests on the solenoid body.

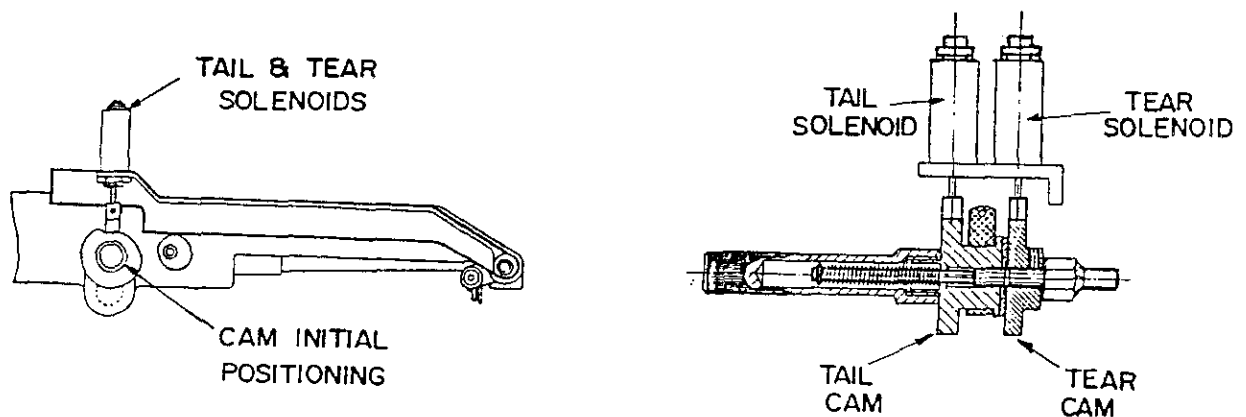

Figure 9-10 Tail and Tear Cams - Initial Positioning

## BASE ASSEMBLY

The Base Assembly houses the mechanism for maneuvering the Workholder Table, the Control Panels, electronic circuit boards that control the operation of the machine, the Temperature Controller and the Manual Z mechanisms.

The mechanism for maneuvering the Workholder Table consists of two interconnected subassemblies: the Manipulator Assembly and the Chessman Handle.

### The Manipulator Assembly

The Manipulator Assembly supports the Workholder Table on the Manipulator Body. The Manipulator Body is a four-sided plate which glides on three bearing-ball raceways (pads) in the Base.

The Manipulator Body is guided in the X and Y directions by guide rods which pass between spring-loaded pairs of rollers. The four guide rods form a cross extending from the edges of the X-Y Frame under the Manipulator Body.

The Manipulator Assembly is shown in Figure 9-11.



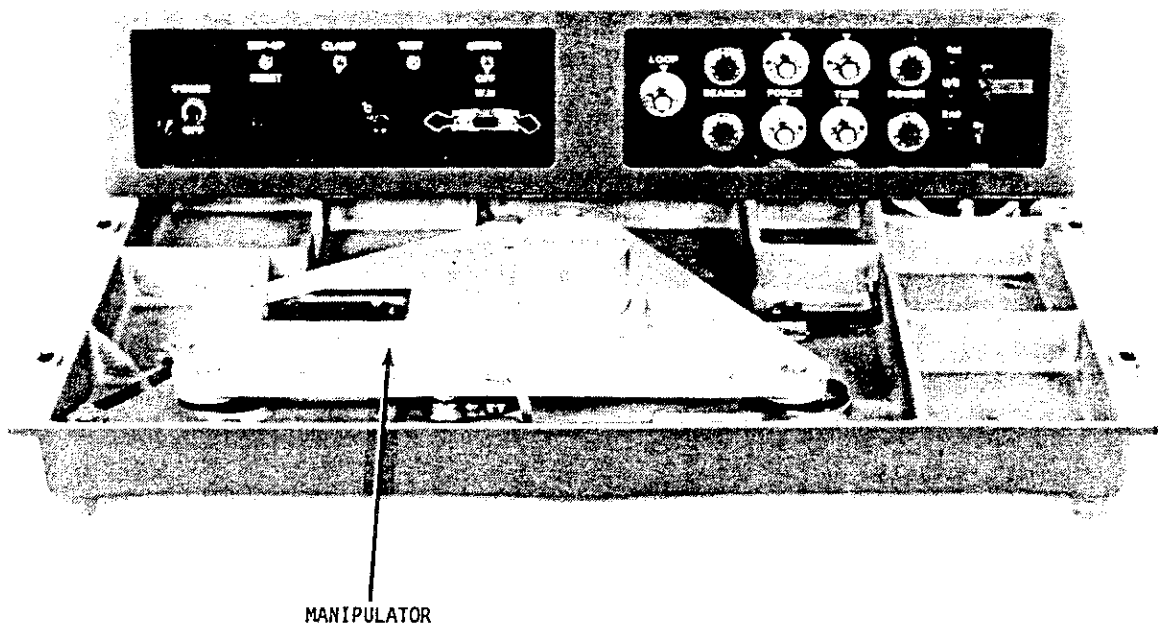

Figure 9-11 The Manipulator Assembly

### The Chessman Handle

The Chessman Handle located at the rear of the left arm rest of the Base is the fine manipulation control. The Chessman Handle is linked to the Manipulator Assembly by way of the Chessman Rod through three spherical bearings: one in the Base, one in the Manipulator Body, and one in the Chessman Case. Manual motion of the Chessman is translated by a ratio 6:1 to the Manipulator Assembly by the lever effect of the Chessman Rod.

The Chessman Handle also contains the CHESSMAN pushbutton for controlling the semi-automatic Chessman Cycle, and the STITCH pushbutton which is used in making continuous stitch bonds.

The Chessman Handle is shown disassembled in Figure 9-12 below.

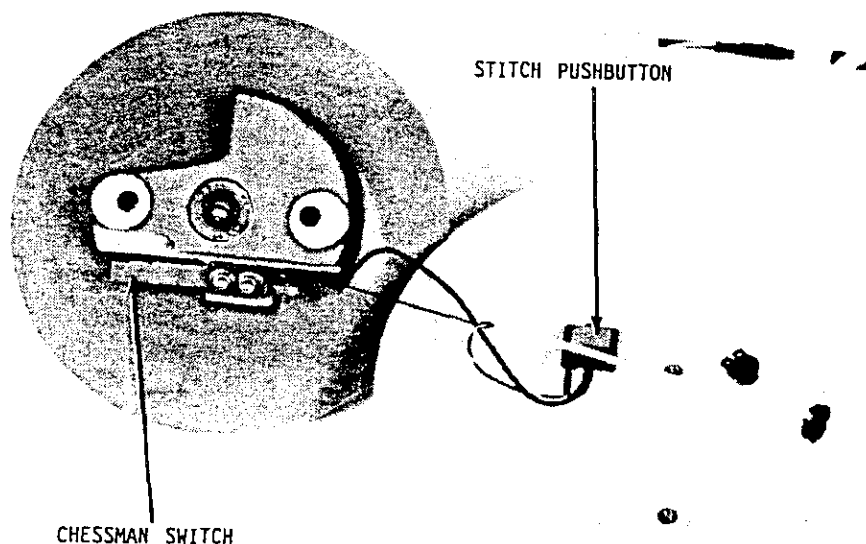

Figure 9-12 The Chessman Handle (Disassembled)

### Chessman Assembly Removal

In order to access the inside of the Base, it is necessary to first remove the Chessman Assembly.

- Step 1 Slide the machine forward (being careful that it does not fall from the bench) to access its under side. From underneath the machine, while holding the Chessman rod with pliers, remove the Chessman retaining screw (see Figure 9-13).

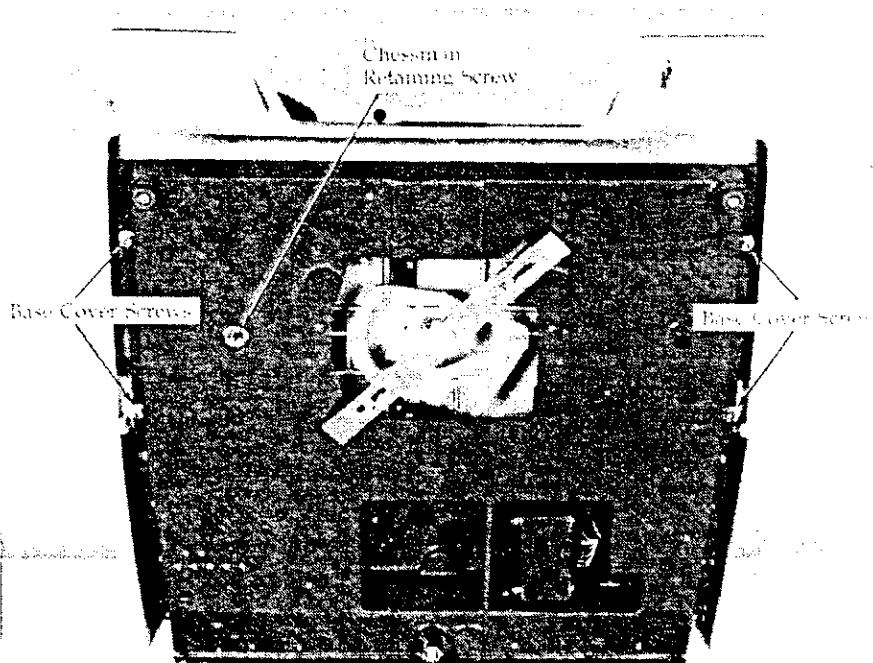

Figure 9-13 The Underside of the Base

- Step 2 Slide the machine back on the bench and pull the Chessman assembly up out of the Base bearing well.

When reinstalling the Chessman, from above the Base align the spherical bearing of the Manipulator with the spherical bearing of the Base and insert the Chessman rod down into the Base well until the Chessman rests on the surface of the Base cover. Then slide the machine forward and screw in the retaining screw from the bottom of the machine.

### Chessman Disassembly

Disassembling the Chessman may be required in order to service the internal parts of the Chessman or to replace the Chessman switches.

Step 1 Remove the Chessman Cover [dwg 4123-220-000 Item (2)] by removing the two retaining screws [dwg 4123-220-000 Item (G)]. Then separate the cover from the Chessman Housing [dwg 4123-220-000 Item (3)].

### Replacing CHESSMAN Pushbutton

Step 2 Disconnect the red and black wires [dwg 4123-1401-000 Item (E)] from the pushbutton.

Step 3 Remove the old CHESSMAN pushbutton by removing the two retaining screws [dwg 4123-220-000 Item (G)] that hold the CHESSMAN pushbutton to the Chessman Housing, and install the new CHESSMAN switch [dwg 4123-1401-000 Item (1)] in its place.

### NOTE

Make sure that in installing the new CHESSMAN switch that the Retaining Grip Ring [dwg 4123-220-000 Item (B)] is placed on the end of the pushbutton such that when the Chessman Cover is screwed down over the Chessman Housing, the pushbutton does not exert any pressure between the housing and the cover.

Step 4 Reconnect the wires. Make sure that the harness is kept clear of being caught between the Chessman housing and cover when the cover is reattached.

Step 5 Check that the new CHESSMAN switch operates properly by stepping the machine through a couple of cycles.

Step 6 Reassemble the Chessman.

### Disassembling the Manipulator

The Manipulator may have to be disassembled for maintenance and cleaning of the bearings, and in case the ball bearings upon which the Manipulator glides have shifted from the pads.

- Step 1 Remove the Chessman by removing the retaining screw holding the Chessman Rod to the lower spherical bearing (see above).
- Step 2 Remove the Workholder Table by taking out the two retaining screws.
- Step 3 Remove the Base Cover by taking out the four retaining screws.
- Step 4 Disconnect the Negator Spring and Ground cable from the Manipulator and take the Manipulator out of its well in the Base by pressing on the Base levers [dwg 4123-211-000 Item (9)] and pulling up on the Manipulator.

Clean the Base interior with a vacuum cleaner to remove all dust and bonding wire residues.

Check for free rotation of all bearings and replace if required. Check the condition of the three ball bearings and clean the raceways with alcohol.

Remove the X-Y Frame from the Manipulator by pressing on the Manipulator levers against the spring. Check the condition of the Manipulator bearings, the ball raceways and the X-Y Frame rods.

To reassemble the Manipulator, first install the X-Y Frame to the Manipulator body in the Y-direction. Then place the three ball bearings in the ball raceway and mount the X-direction rods of the X-Y Frame between the spring loaded bearings and grooved rollers.

Press on top of the Manipulator and check that it glides freely on all three ball bearings.

**Spotlight Lamp Replacement**  
[refer to Figure 2-5]

K&S P/N for replacement lamp is 12933-5424-000

- Step 1 In order to access the lamp, you first separate the lamp housing from the source. Unscrew the two screws and then twist the Cover in a counter-clockwise direction until it is clear of the retaining thread and then take the Cover off.
- Step 2 Press down slightly and twist the Lamp in a counter-clockwise direction until it is free of the Lamp Holder.
- Step 3 Insert the new Lamp into the Lamp Holder. Press down slightly and twist the Lamp in a clockwise direction until it is firmly seated in the Lamp Holder. Make sure that the contacts of the Lamp are in contact with the pins of the Lamp Holder.
- Step 4 Replace the Cover and twist it in a clockwise direction until it is well seated. Secure it with the two screws.

*Incandescent Lamp*  
*12918-1421-000 \$12.62*

*A3913*

## THE MANUAL Z ASSEMBLY

The optional Manual Z Assembly provides the operator with the ability of manually controlling the bonding maneuvers. The Manual Z Assembly has three major components: the Z Lever, the Z Photocell and the Z LVDT.

The Manual Z Assembly is shown in Figure 9-14.

### The Z Lever

The Z Lever, located in the Right Control Panel, pivots on a bearing fastened to the Base. When the Z Lever is lowered, it transmits motion through a vertical lever, a ball joint and a push rod, driving the core through the Z LVDT.

When the Z Lever is released, the Z Return Spring raises the Z Lever to its original position and retracts the core from the Z LVDT winding. Two screws limit downward and upward travels of the lever.

### The Z Photocell

The Z Photocell (optocoupler) Subassembly is activated when the Photocell Flag on the Z Lever is lowered, clearing the path between the light source and the photo detector. The resulting signal to the Logic Board switches the machine to the Manual Z mode, in which the bonding cycle is controlled by the motion of the Z Lever. Raising the Z Lever with its Photocell Flag re-masks the photocell, and after the second bond automatically returns logic to the semi-automatic Chessman mode. The tear and wire feed (tail formation) are performed automatically.

### The Z LVDT

The Z LVDT (linear variable differential transformer) serves the same purpose for the Manual Z mode as the LVDT in the Main Head does for the Chessman mode. It converts linear motion of the core into electrical signals.

The principal elements of the Z LVDT are the stationary windings and the moving core. Output voltage is proportional to the displacement of the core. On the Logic Board, the Z LVDT output is interpreted as a variable reference signal for raising and lowering the Wedge and for synchronizing the cycle.

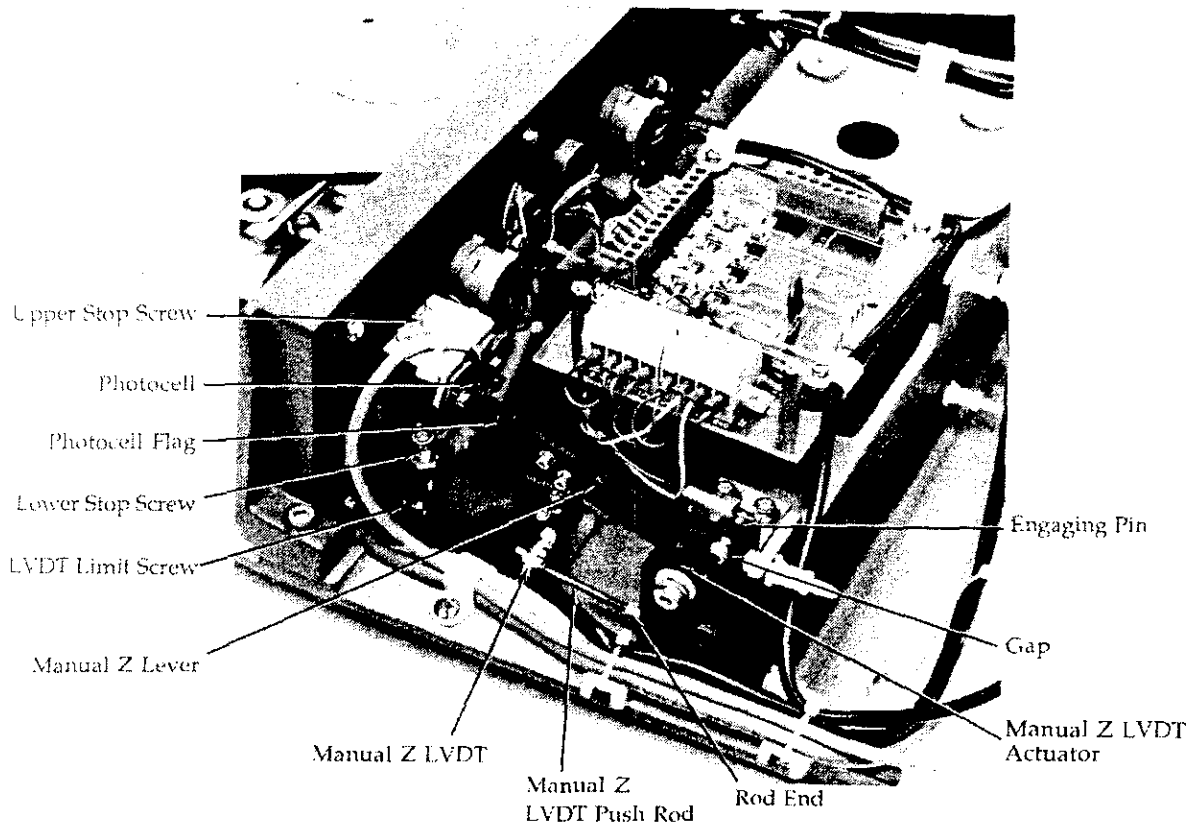

Figure 9-14 The Manual Z Assembly



**Manual Z Photocell Flag Adjustment**

The Flag serves to block the path between the light source on one side of the Photocell and the photo detector on the other. When the Z Lever is pushed down, the Flag moves out of the slot and the Photocell activates, thereby signalling the Logic Board to place the machine in the Manual Z mode of operation. If the Flag does not completely cover the Photocell when the Z Lever is in the up position, this can cause the Logic Board to misinterpret the desired mode of operation.

- Step 1     Using an Allen wrench, loosen the two screws that secure the Flag to the Z Lever.
- Step 2     Adjust the Flag up or down such that it completely fills the Photocell slot.
- Step 3     Tighten the two securing screws.

**Manual Z Engaging Pin Gap Adjustment**

The function of the Engaging Pin is to actuate the Manual Z LVDT. When the Z Lever is pressed down, the Engaging Pin presses on the Manual Z LVDT actuator arm pulling the Push Rod out of the LVDT. This signals the Logic Board to activate the Z Motor for a downward motion of the Bonding Head. A 15 mil (0.35 - 0.4 mm) gap is required to give the Logic Board time to react to the Photocell Flag uncovering the Photocell (and entering the Manual Z mode). If the gap is less than 15 mil, erroneous Bonding Head movements may result.

- Step 1     While holding the Rod End with one wrench, screw the Z LVDT Push Rod in a CW direction with another wrench.
- Step 2     Measure the gap between the Engaging Pin and the LVDT Actuator Rod pivot for a gap of 10-15 mil (0.25-0.37 mm).

### Manual Z LVDT Adjustment

In order for the Logic Board to position the Bonding Head properly in the Manual Z Mode, it must be able to interpret the Manual Z LVDT correctly.

- Step 1 Turn the machine on and verify that the Bonding Head is in the Reset position (only the 1st indicator LED is illuminated).
- Step 2 Connect a voltmeter to test points on the Logic Board (see Chapter 8) with the active probe on TP 6 (MAN.Z) and the ground on TP 7 (GND).
- Step 3 Verify that the measured voltage is 0 V (zero volts). If the voltage is anything else, then, using an Allen wrench, loosen the clamp holding the Manual Z LVDT by unscrewing the retaining screw. Now push the Manual Z LVDT back (or forth) until you get a 0 V reading on the voltmeter.
- Make sure that the Z Lever is stopped by the upper limit screw and not by the top edge of the Z Lever slot in the Right Control Panel.
- Step 4 Tighten down the retaining screw and remeasure the voltage (to ensure that it is still 0 V). If it is not 0 V, then repeat Step 3.

### Manual Z Overtravel Position Adjustment

The Logic Board "knows" when the Bonding Head has reached the Overtravel position (and thereby when to stop the Z Motor) by the receipt of a specific voltage value from the LVDT. This procedure is performed so that the sending of the Overtravel voltage coincides with the Z Lever in the fully down position.

- Step 1 Turn the machine on and verify that the Bonding Head in the Reset position (only the 1st indicator LED is illuminated).
- Step 2 Connect a voltmeter to test points on the Logic Board (see Chapter 8) with the active probe on TP 6 (MAN.Z) and the ground on TP 7 (GND).
- Step 3 Depress the Z Lever to fully down position (i.e., the Z Lever is stopped by the Lower Stop Screw). Measure the voltage, it should be +2.5 V.
- Step 4 If the voltage is not +2.5 V, unscrew (or screw in) the Lower Stop Screw until it stops the Z Lever when the voltage reading is +2.5 V.

TIMING DIAGRAM

To aid the technician in tracking the motion and operation of the K&S 4123 Wedge Bonder this chapter presents the machine time and motion, in schematic form, of the bonding cycle.

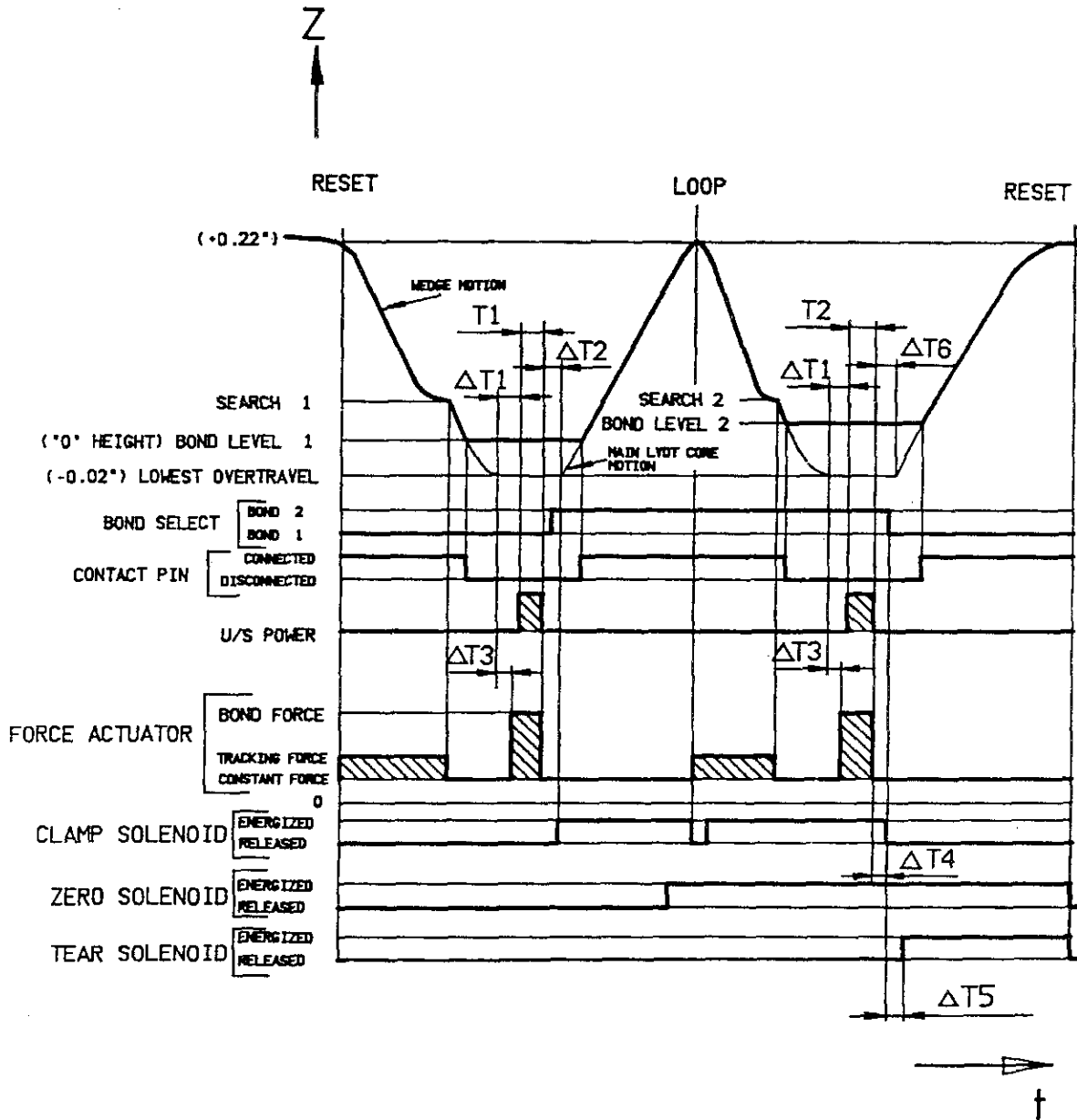

Figure 10-1 Chessman Mode Bonding Cycle Time Study

### Timing Diagram Explanation

The various times shown in Figure 10-1 represent reaction times of the Logic Unit in sending electrical control signals. These times represent the following:

T1 is the time of the first bond.

T2 is the time of the second bond.

Delay  $\Delta T1$  is the time interval required by the logic, once the LVDT core has reached its forward position, to initiate the ultrasonic power pulses.

Delay  $\Delta T2$  is the time interval required by the logic, once the first bond has been accomplished, to initiate the Z Motor Cam-LVDT reversal to raise the Bonding Head to the Loop position.

Delay  $\Delta T3$  is the time interval required by the logic, once the LVDT core has reached its most forward position, to initiate the bond force.

Delay  $\Delta T4$  is the time interval, after the second bond has been performed, required to de-energize the Clamp Solenoid.

Delay  $\Delta T5$  is the time interval between the de-energizing of the Clamp Solenoid and the energizing of the Tear Solenoid.

Delay  $\Delta T6$  is the time interval, after the accomplishment of the second bond, between the reversal of the Z Motor reversal and the raising of the Bonding Head to the Reset position.

## DIAGNOSTICS

Whenever the K&S 4123 Wedge Bonder is powered up, or reset, the machine performs an automatic self test. During this test, the machine checks the Ultrasonic Transducer, Force Coil, Clamp (checked only in the power up routine) and Tail Solenoid, and the Contact Pin. The 4123 indicates that the test is being run by the simultaneous illumination of the two LEDs 1st and 2nd on the Right Control Panel. At the successful conclusion of the self test, the LED 2nd goes out leaving only 1st illuminated indicating that the machine is ready for operation.

If the machine detects a fault, it turns on LEDs DS1-DS4 (referred to as the Diagnostic LEDs) on the Logic Board. The LEDs are visible on the Back Panel of the Base. The nature of the fault is indicated by which of the LEDs are illuminated. That is, each fault has its own code which is represented by the combination of illuminated Diagnostic LEDs. If more than one fault is detected, the one having the highest code value is displayed.

The Diagnostic LEDs will also illuminate due to certain faults in the bonding cycle:

- \* If the Bonding Head fails to reach a Search position (i.e., something is wrong with the Z Motor), the 1st LED on the Right Control Panel will illuminate blinking and the Diagnostic LEDs will illuminate indicating the fault code.
- \* If the Bonding Head hangs up in the Loop position for more than 3 minutes, or the CLAMP switch is left on, the 2nd LED will illuminate blinking and the appropriate Diagnostic LEDs will illuminate.

After the fault has been corrected, normal machine operations can be reinitiated by pressing the RESET switch on the Left Control Panel.

Table 11-1 lists the fault codes, which Diagnostic LEDs are illuminated and the fault associated with the code.

Table 11-1 4123 Fault Codes

Code	D S 4	D S 3	D S 2	D S 1	Fault
01	0	0	0	x	Timeout in Loop position, or timeout Clamp in Reset position reached.
02	0	0	x	0	Open circuit in Force Coil.
04	0	x	0	0	High impedance in the Transducer, or Transducer disconnected.
06	0	x	x	0	Contact signal not received, or fault in Contact mechanism.
07	0	x	x	x	Open Clamp Solenoid circuit detected.
08	x	0	0	0	Open Tail Solenoid circuit detected.
10	x	0	x	0	No completion of 2nd bond received from External Ultrasonic Generator, if installed.
12	x	x	0	0	Z Motor did not drive Bonding Head to Search position.
14	x	x	x	0	No starting Busy signal received from the External Ultrasonic Generator, if installed.

## Legend:

x - LED illuminated and blinking  
0 - LED off

## PREVENTIVE MAINTENANCE

This chapter provides the maintenance schedule for various subassemblies of the K&S 4123 Wedge Bonder. Adhering to this schedule maximizes the useful life of the machine as well as ensuring trouble free operation.

## CAUTION

Unless otherwise instructed, never lubricate any part of the machine. Oil attracts dust and debris which can seriously degrade the operation of the bonder.

Table 12-1 Preventive Maintenance Schedule

Activity	M	Q	A
Clean Bonding Head Contact Pin and Screw	x		
Clean Wire Clamps	x		
Check Force Actuator Coil		x	
Check Z Motor Drive Belt Tension		x	
Check Bonding Head Movement and Dashpot			x
Clean Manipulator and Base			x
Check Cam Follower Bearing			x
Check Height Control Link Motion			x
Adjust LVDT Oscillator Voltage			x
Adjust Ultrasonic Generator			x
Adjust Temperature Controller Zero Offset			x
Clean Tear and Tail Solenoids			x

M - Monthly Q - Quarterly A - Annually



**Clean the Bonding Head Contact Pin and Screw**

An unclean Contact Pin can cause serious deviations in the tail length.

**Reference Drawing:** 4123-0450-000 (Contact Pin)  
4123-0455-000 (Height Control Screw)

**Required:** Monthly

**Required Tools and Materials:**

Cotton swabs  
Acetone

**Procedure:**

- Step 1 Turn machine off.
- Step 2 Using a cotton swab dipped in Acetone, thoroughly clean the Contact Pin.
- Step 3 Also thoroughly clean the Height Control Screw.

### Clean Wire Clamps

These two assemblies must be clean as they are in constant contact with the wire.

**Reference P/N:** 4123-0770-000

**Required:** Monthly

**Required Tools and Materials:**

Lens cleaning paper

**Procedure:**

- Step 1 Turn the machine off.
- Step 2 Pass the lens paper through the Wire Clamps several times.
- Step 3 Pass a length of wire through the clamps and check that there is no residue or dirt remaining.

**Check Force Actuator Coil Motion**

Reference P/N: 4123-0417-000

Required: Quarterly

**Required Tools and Materials:**

Air gun  
Sticky tape

**Procedure:**

- Step 1 Turn the machine on.
- Step 2 Position the SET-UP/RESET switch to SET-UP and rotate the FORCE dials to minimum force.
- Step 3 With your finger, push the Coil downward and then release it. If it returns to its original position, exit this procedure.

If the Coil does not return to its original position, this is a sign that there is some impediment inside.

- Step 4 Turn the machine off.
- Step 5 In order to verify that the Coil is not stuck, you must remove the Force Actuator (see Chapter 9) from the machine and see if the Coil falls freely through the magnet's groove. Check this several times by turning the Coil slightly each time and then letting it drop through the magnet's groove.
- Step 6 If the Coil sticks (i.e., does not fall through the magnet's groove), check if there are any magnetic flakes in the groove. If there are, extract them by running a strip of sticky tape through the groove. If the material clogging the groove is just dirt (non-magnetic), clean it out by a blast of air from the air gun.

If the Coil is bent, then replace the Coil (see Chapter 9).

### Check Z Motor Drive Belt Tension

Reference Drawing: 4123-0405-000

Required: Quarterly

**Procedure:**

- Step 1 Turn the machine off.
- Step 2 Open the rightside cover of the Main Head, rotate the Z Motor pulley by hand and check that the belt does not slip. If it does slip, replace it.
- Step 3 Turn the machine on.
- Step 4 Cycle the machine a few times (by repeatedly pressing the CHESSMAN pushbutton). Check that Error Code 12 (see Chapter 11) does not appear in the Diagnostic Indicators.

If Error Code 12 does appear, replace the belt.

**Check Bonding Head Movement and Dashpot**

**Reference Drawing:** 4124-410-000 (Angular Contact Bearing)  
4123-405-000 (Air Dashpot)

**Required:** Annually

**Procedure:**

Step 1 Turn machine off.

Step 2 With your finger, lift the Bonding Head up as far as it will go and then let it fall freely. Check that the movement is smooth.

If the Bonding Head descends smoothly, exit this procedure.

Step 3 Check the Angular Contact Bearing. If the Bearing Screw Support is too tight, loosen it and recheck the movement of the Bonding Head. If the bearing is defective, replace it (see Chapter 9).

If there is nothing wrong with the Angular Contact Bearing, check the Air Dashpot, particularly the joint of the Dashpot Rod. The easiest way to check is by deflecting the Dashpot, the Dashpot Rod should drop off the frame. If it does not, this is a sign that the Dashpot has to be replaced.

**Clean Manipulator and Base**

**Reference Drawing:** 4123-0211-000  
4124-0212-020

**Required:** Annually

**Required Tools and Materials:**

Vacuum cleaner  
Lint-free cloth  
Cotton swabs  
Alcohol  
Silicon grease

**Procedure:**

- Step 1 Turn the machine off and unplug it from the mains.
- Step 2 Remove the Chessman from the Base (see Chapter 9) and put it aside.
- Step 3 Remove the Workholder Table from the Base.
- Step 4 Remove the Base cover and remove the Manipulator.
- Step 5 With the vacuum cleaner, clean out all dust particles and wire residue from the Base well and the Manipulator.
- Step 6 Using cotton swabs soaked in alcohol, clean all ball raceway pads (the three located in the Base well and the three located on the Manipulator). Clean the three ball bearings.
- Step 7 Using lint-free cloth and alcohol, clean the Manipulator X-Y frame rods and all bearings. Check that the bearings move freely. If any bearings are defective, replace all bearings.
- Step 8 With a cotton swab, smear a thin layer of silicon grease on the Chessman Rod.
- Step 9 Reassemble the Base and make sure that the Manipulator rests on all three ball bearings.

**Check Cam Follower Bearing**

**Reference Drawing:** 4123-0455-000

**Required:** Annually

**Required Tools and Materials:**

Allen and Open Wrenches

Loctite 222

**Procedure:**

- Step 1 Turn machine off.
- Step 2 Release back edge of Height Control Link return spring from pin.
- Step 3 Rotate Cam Follower bearing with your finger. The bearing should rotate freely.
- Step 4 Re-adjust the mounting screw of the bearing if there is no free rotation. Tightening the screw will increase the friction on the bearing. Afterwards, secure the screw with Loctite 222, making sure that no Loctite gets into the bearing.

**Check Height Control Link Motion**

Reference Drawing: 4123-405-000

Required: Annually

**Procedure:**

- Step 1 Turn machine off.
- Step 2 Disconnect the Height Control Link return spring (Item 8 of reference dwg) and check that the link pivots freely.
- Step 3 If the link does not pivot freely, check for friction in the motion of the LVDT core pin and adjust alignment of the LVDT housing with the push rod until a smooth motion is achieved.

Also check the Height Control Link bearings for smooth motion. If the motion is not free, adjust the spring loading of the bearings by tightening or releasing the nuts (Item AA of the reference dwg), or replace the bearings [dwg 4123-455-000 Item (E)].

- Step 4 If you have adjusted the LVDT or released the LVDT push rod, re-adjust the Reset position and verticality (see Chapter 9).



Adjust LVDT Oscillator Voltage

In this procedure you check for the 18 V<sub>ptp</sub>. If this voltage is correct, then you are assured that the machine accurately measures the distance between the Reset position and that of Overtravel.

Reference Drawing: 4125-4200-000

Required: Annually

Required Tools and Materials:

Oscilloscope (or DVM)

Procedure:

Step 1 With the machine on, place the active probe of the oscilloscope (or DVM) on TP 4 (S.W.) and the ground probe on TP 7 (GND) of the Logic Board.

Step 2 Check that the voltage is 18 V<sub>ptp</sub> (or, if using a DVM, 6.37 V<sub>rms</sub>). If the voltage is not correct, adjust it (see Chapter 8).

*Don*  
P 14-6 (SW)  
P 14-7 (GND)  
TP4 to TP7  
reads 7.8 Volts RMS

Adjust ULTRASONIC GENERATOR

In this procedure you check ultrasonic free running frequency and power.  
For details see CHAPTER 8.

Reference Drawing: 4125-4200-000

Required: Annually

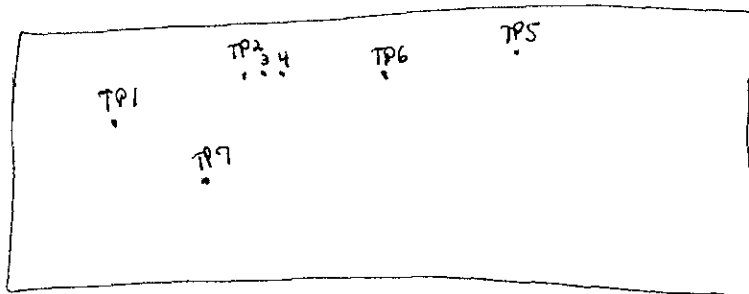

### Adjust Temperature Controller Zero Offset

This procedure is performed on those machines in which a KTC Temperature Controller is installed.

**Reference Figure:** Figure 3-1

**Required:** Annually

**Required Tools and Materials:**

Digital Thermometer  
Small flathead screwdriver

**Procedure:**

- Step 1 Turn the machine on and make sure that the Workholder is plugged into the Temperature Controller.
- Step 2 On the Left Control Panel, press the DISPLAY SELECT pushbutton to display the Set temperature of the Temperature Controller. Set the Temperature Controller to the working temperature (120°C to 200°C). Let the Workholder temperature stabilize for about 20 minutes.
- Step 3 Using the external thermometer, measure the actual temperature of the Workholder surface.
- Step 4 Insert the screwdriver into the Zero Offset Adjustment hole on the Left Control Panel and turn the trimmer potentiometer clockwise or counter-clockwise until the reading of the Temperature Controller is the same as the reading of the external thermometer.

**Clean Tear and Tail Solenoids**

As a result of their activities, over a period of time grime forms on the solenoid pistons and can buildup within the solenoids. If it collects too much within the solenoids, it can weaken the magnetic power.

**Reference P/N:** 4123-1710-000 (Tail Solenoid)  
4123-1720-000 (Tear Solenoid)

**Required:** Annually

**Required Tools and Materials:**

Lint-free cloth  
Cotton swab  
Gentle cleaning solvent

**Procedure:**

- Step 1 Remove each solenoid (see Chapter 9)
- Step 2 Remove the pistons from within the solenoids and wipe them and the outside of each solenoid clean with cloth dipped in the cleaning solvent.
- Step 3 With a cotton swab dipped in the cleaning solvent clean out the inside of each solenoid.
- Step 4 Reinstall the solenoids (see Chapter 9).

**TROUBLESHOOTING**

This chapter contains the procedures for troubleshooting the K&S 4123 Wedge Bonder.

**CAUTION**

In troubleshooting the 4123, do not attempt any repair work beyond that given in this chapter. Should situations arise that are not covered by this chapter or the problem is not corrected after performing the procedure, please contact your dealer or the manufacturer. Performing unauthorized maintenance may lead to serious damage to the machine.

**CAUTION**

Never remove any plug from the Logic Board when power is applied to the machine. This can damage the internal circuits of the Logic Board.

The procedure steps are generally arranged in a sequence that begins with the more simple action leading to more complex actions. If at any step, the problem is solved, exit the procedure.

## GENERAL

SYMPTOM	ACTION
No power to the machine	<ol style="list-style-type: none"> <li>1. Check that the power cable is connected to the mains and that main power is available.</li> <li>2. Check fuse F2 on the back of the Base. If blown, replace it.</li> </ol>
Workholder does not heat up	<ol style="list-style-type: none"> <li>1. Check that the power cable is connected to the mains and that main power is available.</li> <li>2. Check fuse F1 on the back of the Base. If blown, replace it.</li> <li>3. Check fuse F1 on the KTC board, if blown, replace it.</li> <li>4. Check Workholder harness and continuity of the thermocouple harness.</li> </ol>
Illumination Lamp does not light up	<ol style="list-style-type: none"> <li>1. Check bulb, if burned out, replace it.</li> <li>2. Check connection of lamp to Mother Board (J4), if faulty, correct it.</li> <li>3. Check fuse F1 on the Mother Board, if blown, replace it.</li> </ol>
Spotlight does not light up	<ol style="list-style-type: none"> <li>1. Check bulb, if burned out, replace it.</li> <li>2. Check connection of lamp to Mother Board (J5), if faulty, correct it.</li> <li>3. Check fuse F2 on the Mother Board, if blown, replace it.</li> </ol>

SYMPTOM	ACTION
The machine does not cycle properly, or performs improper bonding.	<ol style="list-style-type: none"><li data-bbox="773 399 1373 493">1. Check fuses F3 and F4 on the Mother Board, if either or both blown, replace fuse(s).</li></ol> <p data-bbox="979 524 1060 551"><b>NOTE</b></p> <p data-bbox="846 586 1390 803">Although the machine will still operate if only one of the fuses is blown, the fuse must be replaced. Otherwise problems may be caused with the software and ultrasonic energy.</p>
Self test not performed on startup or reset (indicated by nonillumination of LEDs 1st and 2nd when machine turned on or reset)	<ol style="list-style-type: none"><li data-bbox="773 872 1373 996">1. Check fuses F3 and F4 on the Mother Board, if this is the cause, both will be blown. Replace them both.</li><li data-bbox="773 1027 1438 1120">2. Check that jumper W6 is correct. If not, connect it correctly (see Chapter 8).</li><li data-bbox="773 1152 1406 1309">3. On the Logic Board, check for +5 Vdc on pin U4/3 and +27 Vdc on test point P12/7. If they are not present, replace the Logic Board.</li></ol>

SYMPTOM	ACTION
Z Motor does not cycle properly, or does not operate at all	<ol style="list-style-type: none"><li>1. Check that the MOTOR/OFF switch on the Left Control Panel is in the on position.</li><li>2. If Manual Z is installed, check Manual Z Flag is well seated in the Photocell, if not adjust it.</li><li>3. Check if the CLAMP switch has been left in the On position (the 2nd LED blinking). If it has, position it to Off and press RESET.</li><li>4. Check the drive belt of the motor, if defective or slipping, replace it.</li><li>5. Check the Chessman pushbutton, if defective, replace it.</li><li>6. Check that jumpers W5, W6 and W7 on the Logic Board are set properly, if not correct jumper configuration (see Chapter 8).</li><li>7. Check <math>\pm 15</math> Vdc on Logic Board (+15 Vdc is checked on pin U2/3 and -15 Vdc on pin U3/3). If not present, replace the Logic Board.</li></ol>

SYMPTOM	ACTION
Uncontrolled rotation of the Z Motor	<ol style="list-style-type: none"> <li>1. Turn the machine off and then on.</li> <li>2. On the Logic Board, check for the presence of +15 Vdc on pin U2/3 and -15 Vdc on pin U3/3. If they are not present, replace the Logic Board.</li> <li>3. On the Logic Board, check for 18 Vptp (or 6.37 Vrms) on test point TP4. If it is not correct, adjust it. If it is not present, replace the Logic Board.</li> <li>4. On the Logic Board, check for 0 Vdc (if Bonding Head is in the Reset position) or +2.5 Vdc (if Bonding Head is in the Overtravel position) on pin U17/7. If not present, replace the Logic Board.</li> <li>5. Check that the drive belt is not slipping. If it is slipping, replace it.</li> <li>6. Check the Height Control Link system: <ul style="list-style-type: none"> <li>- Check that the Bonding Head is not obstructed.</li> <li>- Check that the Height Control Link correctly tracks the movement of the Cam.</li> <li>- Check that the LVDT is not damaged.</li> </ul> </li> </ol>



SYMPTOM	ACTION
No response to CHESSMAN pushbutton	<ol style="list-style-type: none"> <li>1. Check the Logic Board connection (P5 - see Chapter 8). Plug in the harness if it is out.</li> <li>2. Check CHESSMAN pushbutton. If it is stuck, unstick it.</li> <li>3. Replace CHESSMAN pushbutton (see Chapter 9)</li> </ol>
Manual Z Photocell Flag improperly adjusted, or Photocell is faulty (Bonding Head does not respond in a proper manner)	<p>Check Manual Z Photocell Flag, and Photocell.</p> <ul style="list-style-type: none"> <li>- First unplug Photocell harness from the Logic Board (P10 see Chapter 8).</li> <li>- Check if machine cycles, adjust Photocell Flag. If Flag is all right, replace Photocell (see Chapter 9).</li> </ul>

**BONDING PROCESS**

Troubleshooting faults that may appear during machine operation is complicated by the number of factors involved during each stage of the bonding process. To aid you in cases when bonding process faults are experienced, the following table has been arranged not only by fault, but, within the fault, suggested possible causes. To effectively use the table, you should check the probable causes and visually inspect the machine to see which cause is the most likely and then perform the actions for that cause.

In almost all cases, you should first check the Diagnostic LEDs for indications.

SYMPTOM	ACTION
<p>U/S indicator does not illuminate when TEST pressed</p> <p>Possible Cause:</p>	
<p>Wedge is improperly installed</p>	<p>Check that the Wedge is installed according to the Setup Gauge. If not, adjust the Wedge (see Chapter 4).</p>
<p>Wedge is damaged or broken</p>	<p>Replace Wedge (see Chapter 4)</p>
<p>Transducer is not receiving power, or power is inadequate</p>	<ol style="list-style-type: none"> <li>1. Check that the Transducer is plugged into the Logic Board (J1 see Chapter 8).</li> <li>2. Check the Ultrasonic free running frequency and power. Adjust as per procedure in Chapter 8</li> </ol>
<p>Transducer is not properly clamped in the Bonding Head</p>	<p>Check that the clamping torque of the Transducer U-Bolt nuts is 7 kg-cm. If not, adjust torque.</p>
<p>Faulty Transducer</p>	<p>Check Diagnostic LEDs for error code 04 . If this code appears replace the Transducer</p>
<p>Faulty Logic Board</p>	<p>Replace the Logic Board.</p>

SYMPTOM	ACTION
<p>Bonds do not adhere or are not consistent</p> <p>Possible Cause:</p>	
<p>Bonding parameters are incorrect</p>	<p>Change the bonding parameters one at a time to find the proper balance.</p>
<p>Bonding surface is dirty, or wire is dirty</p>	<ol style="list-style-type: none"> <li>1. Check the surface of the device. If dirty, clean surface.</li> <li>2. Check wire. If dirty, replace wire.</li> </ol>
<p>Poor metalization</p>	<p>Try using another device.</p>
<p>Device is not clamped properly</p>	<p>Check that device lies flat on the Workholder and is properly clamped. If not, adjust device.</p>
<p>Wedge is clogged or broken</p>	<p>Check Wedge. Clean if clogged. Replace if broken.</p>
<p>Wedge is not set correctly</p>	<p>Check if Wedge installed properly. If not, reinstall Wedge using setup gauge (see Chapter 4)</p>
<p>Search position is not set properly</p>	<p>Check that Search position is 0.005" (0.127 mm) above the bonding surface. If not, readjust the Search position, or Workholder height.</p>
<p>Dashpot set for too much damping, or is faulty</p>	<ol style="list-style-type: none"> <li>1. Check that the Dashpot is not overtight. Loosen Dashpot by turning valve counter-clockwise.</li> <li>2. Replace Dashpot (see Chapter 9).</li> </ol>

SYMPTOM	ACTION
Bonds do not adhere or are inconsistent (Continued)	
Force Actuator coil is stuck	Check that the Force Actuator coil is not sticking. If it is, clean or replace it, as needed.
Wire is too old	If the wire is over six months old, replace it.
Workholder not heating properly (gold wire)	<ol style="list-style-type: none"> <li>1. Check that the temperature of the Workholder is properly set, and that the Workholder temperature matches the Set Temperature (see Chapter 4).</li> <li>2. Adjust Temperature Controller offset (see Chapter 12).</li> </ol>
U/S Transducer out of order	Press RESET switch. Check Diagnostic LEDs for faulty Transducer code (see Chapter 11). If present, replace Transducer.
Wire Clamp does not open	<ol style="list-style-type: none"> <li>1. Reduce the clamping force (see Chapter 9)</li> <li>2. Check Clamp Solenoid, replace if faulty.</li> </ol>

SYMPTOM	ACTION
<p>Bonds do not adhere or are inconsistent (Continued)</p>	
<p>Bonding Head movement is improper</p>	<ol style="list-style-type: none"> <li>1. Check that no cables interfere with the movement.</li> <li>2. Check that the counterweights are providing the proper static force (see Chapter 9).</li> <li>3. Adjust or replace Bonding Head bearings (see Chapter 9).</li> </ol>
<p>Backlash in the Manipulator or missing ball bearing</p>	<p>Check conditions of the ball bearings in the Base and on the Manipulator, replace if needed. Check that the raceways are clean.</p>
<p>Operator moves the Chessman while bonding</p>	<p>Check that the operator holds the Chessman steady when bonding.</p>
<p>Wire breaks just above first bond</p> <p>Possible Cause:</p> <p>Overly squashed bond</p> <p>Heel cracks due to sharp back radius</p> <p>Excessive drag on the wire</p> <p>Wire Clamp does not open</p>	<p>Reduce the bonding parameter settings.</p> <p>Replace Wedge with one that has a larger back radius.</p> <p>Reduce drag of wire by loosening nuts of Spool Holder.</p> <p>Reduce clamping force and check Clamp Solenoid.</p>

SYMPTOM	ACTION
<p>Loop height varies or tangles sideways</p> <p>Possible Cause:</p> <p>Improper LOOP dial setting</p> <p>Improper Wedge</p> <p>Wire improperly threaded through Clamp wire guide</p> <p>Excessive drag on wire</p> <p>Clamp is improperly aligned with the Wedge</p>	<p></p> <p>Change dial setting.</p> <p>Change Wedge.</p> <p>Rethread wire.</p> <p>Loosen wire tension by loosening nuts of Spool Holder.</p> <p>Adjust Clamp sideways position.</p>
<p>Inconsistent Tail length</p> <p>Possible Cause:</p> <p>Clamp is set too far away from the Wedge</p> <p>Clamp is improperly aligned with the Wedge</p> <p>Wire is slipping in the Clamp</p>	<p></p> <p>Readjust Clamp position (see Chapter 9)</p> <p>Adjust Clamp sideways position.</p> <p>Tighten Clamp force spring.</p>

SYMPTOM	ACTION
Inconsistent Tail length (Continued)	
Wire is too soft (gold wire only)	Replace wire with harder wire.
Wedge has too large a back radius	Replace Wedge with one that has a smaller back radius.
Tail/Tear Solenoid improperly adjusted	Readjust Solenoid.
Wedge is clogged or broken	Clean or replace Wedge, as required.
Improper 2nd bond settings	Change 2nd bond settings.
Backlash in wire feed system	Check for backlash along the wire path.
Improper Workholder height	Lower Workholder height.
Wire slipping in Wire Clamp	Check Wire Clamp force (see Chapter 9)
Improper wire tearing	Check Tear gap (see Chapter 9)



SYMPTOM	ACTION
<p>No Tail left in Wedge after 2nd bond</p> <p>Possible Cause:</p> <p>Tail length not properly adjusted</p> <p>Tail Solenoid action is faulty</p> <p>2nd bond too squashed</p>	<p>Readjust Tail length.</p> <p>1. Check Tail Solenoid. Replace if required.</p> <p>2. Check Logic Board connection.</p> <p>Lower 2nd bond settings.</p>
<p>Pig tail attached to bond after 2nd bond (gold wire only)</p> <p>Possible Cause:</p> <p>Wire is too soft</p> <p>Tear and Tail Solenoids improperly adjusted</p> <p>Wire has slipped out of the Wedge</p>	<p>Replace wire with harder wire.</p> <p>Readjust solenoids.</p> <p>Rethread the wire between the Clamp jaws and through the wire guide.</p>

SYMPTOM	ACTION
Stitch bonds cannot be performed  Possible Cause:	
2nd bond parameters are set too high	Lower 2nd bond parameter settings.
Wedge foot is too small for the wire diameter	Replace Wedge with one that has a larger foot, or replace wire with smaller diameter wire.
STITCH pushbutton is faulty	Replace the STITCH pushbutton (see Chapter 9)

**OPTIONS AND ACCESSORIES**

The following list will help in identifying part numbers for optional items that are available for the K&S 4123 Wedge Bonder. For more details, contact your K&S representative or service center.

**Optical Accessories**

<u>K&amp;S Part Number</u>	<u>Description</u>
36731-2694-000	B&L Stereo Zoom 4 Microscope
32531-0561-002	Eyepieces (pair) 10x magnification for the B&L Microscope
32531-0562-020	Eyepieces (pair) 15x magnification for the B&L Microscope
32531-0563-020	Eyepieces (pair) 20x magnification for the B&L Microscope
00800-0008-000	WILD M3Z Stereo Zoom Microscope, 20x magnification eyepieces
00800-0009-000	WILD M3Z Stereo Zoom Microscope, 15x magnification eyepieces
04123-7300-000	Spotlight Targeting Assembly, Ring-Shaped Target
04123-7311-000	Crosshair Target Reticle for the Spotlight (4123-7300-000)
04129-7350-000	Fiber Optic Illumination and Crosshair Targeting System, 100-120 Vac
04129-7351-000	Fiber Optic Illumination and Crosshair Targeting System, 220-240 Vac

## Cold Workholders

<u>K&amp;S Part Number</u>	<u>Description</u>
00483-0051-000	Workholder and Top Plate Assembly for Substrates, adjustable from 1/4" x 1/4" to 1" x 1" x 0.02" to 0.06" thickness
00483-0054-000	Workholder and Top Plate Assembly for T0-5 and T0-18
00483-0058-000	Workholder and Top Plate Assembly for T0-8 Devices with 0.5 diameter
00483-0095-000	Workholder and Top Plate Assembly for T0-8 Devices with 0.6 diameter
00483-0059-000	Workholder and Top Plate Assembly for Substrate, adjustable from 1" x 1" to 2" x 2" x 0.02" to 0.06" thickness
00483-0148-000	Universal Workholder for Flat Ceramic Packages 3/8" to 2" x 2", Chip Carrier, 0.3, 0.4, 0.6, 0.8 and 0.9" Centerline Bent Lead Packages and Side Braze
00483-0158-000	Universal Workholder for Cerdip and Side Braze Devices Lead Centerline 0.3, 0.6 and 0.9"
00483-0107-000	Workholder and Top Plate Assembly for 1/4" x 1/4" Flat Pack Device, Non-adjustable (Note: Consult your K&S representative for Mixed Sizes from 1/8" x 1/8" to 1/2" x 1/2")

## Height-Adjustable Heated Workholders

<u>K&amp;S Part Number</u>	<u>Description</u>
04135-0001-000	Height-Adjustable Rotary Heated Workholder for Substrate and Flat Packages up to 2.5" x 2.5"
04135-0005-000	Height-Adjustable Rotary Heated Workholder with Vacuum Hold Down for Packages and Substrates up to 2.5" x 2.5"
04135-0006-000	Height-Adjustable Rotary Heated Universal Workholder with 0.1" Centerline Slots, 0.25" Deep

## Spare Parts and Maintenance Kits

<u>K&amp;S Part Number</u>	<u>Description</u>
04123-0901-000	Spare Parts Kit for 100/120 V Line Voltage
04123-0902-000	Spare Parts Kit for 220/240 V Line Voltage
04123-7700-000	3rd Channel Kit
04123-0910-000	Maintenance Tool Kit, including Square Block, Verticality Pin and Setup Gauge for Verticality Adjustments of the Bonding Head

## Power Supplies

<u>K&amp;S Part Number</u>	<u>Description</u>
41470-1063-000	Power Supply for Mini Heaters and Heated Capillary Kits for 100/120 V Line Voltage
04123-0904-000	Power Supply for Mini Heaters and Heated Capillary Kits for 220/240 V Line Voltage

## Miscellaneous

<u>K&amp;S Part Number</u>	<u>Description</u>
04123-7550-000	2" Wire Spool Adaptor
04123-7200-000	Manual Z Assembly
04123-0360-000	Height-Adjustable Base Adaptor for Cold Workholders
18527-0004-000	Anti-Static Dust Cover for the Machine (not to be used with machines equipped with Fiber Optic Illuminator)
04461-0000-000	Temperature Controller Model 101-1

**NOTE:** All 4124 Series Stationary Heated Workholders and custom made Workholders are available. Consult your K&S representative.

**SPARE PARTS LIST**

This chapter contains the Spare Parts List for major assemblies of the **K&S Model 4123 Wedge Bonder** as well as reference drawings. The Parts List is provided as an aid for ordering spare or replacement parts for your machine.

## Base Frame

Part Number: 04123-0211-000

COMPONENT PART	ITEM NUMBER	DESCRIPTION
	1	BASE
00478-5002-005	2	SPRING CLIP
04123-0211-002	3	GROOVED ROLLER
04123-0211-003	4	SPACER
04123-0211-005	5	ROLLER
	6	SPRING BUSHING
	7	FOOT
04123-0210-005	8	SHOULDER SCREW
04123-0214-000	9	LEVER ASSY
	10	SPACER FOR NEGATOR SPRING
	11	FUSE HOLDER
	12	GROUND HARNESS
00478-5001-010	13	BALL RETAINER
00484-0001-014	14	BALL RACE WAY
20647-1118-000	B	BEARING, RADIAL BALL FLANGE
	C	BOLT, SPADE 6-32X13/32 THD NP
	C	BOLT, SPADE 6-32X11/16 S/S
20676-1251-000	D	BEARING, SPHERICAL
65000-2574-000	G	NEGATOR SPRING

## Front Panel Assy

Part Number: 04123-0213-000

COMPONENT PART	ITEM NUMBER	DESCRIPTION
	1	U/S HARNESS
	2	POSITION HARNESS
	3	LEFT PANEL HARNESS
	6	FRONT PANEL FRAME
	7	RIGHT PANEL
04320-0005-007	11	SKIRTED KNOB 'FORCE KNOB'
	13	LEFT PANEL
	14	BRACKET
15878-0386-000	A	SWITCH, TOGGLE SPDT
29030-5515-000	B	DIAL, 10 POSITION 'POWER'
15878-6001-000	C	SWITCH, TOGGLE
15878-6002-000	D	SWITCH, TOGGLE
56094-6000-000	J	POT. 1K OHM 2W 5% 10 TURN W.W.
56066-6100-108	P	POT. 1K OHM 2W 10% 1 TURN
55120-6005-000	R	DIODE LED, RED
56094-6000-001	V	POT. 10K OHM 2W 5% 10 TURN W.H
56117-7500-008	W	POT. 50K OHM 2W 10% PANEL MT



## Lever Assy

Part Number: 04123-0214-000

COMPONENT PART	ITEM NUMBER	DESCRIPTION
<hr/>		
	2	LEVER
	C	BEARING, RADIAL BALL FOR LEVER

## X-Y Frame

Part Number: 04123-0215-000

COMPONENT PART	ITEM NUMBER	DESCRIPTION
<hr/>		
	2	X-Y FRAME
	3	PIN, SS 303 FOR CONNECTING X-Y FRAME

Chessman

Part Number: 04123-0220-000

COMPONENT PART	ITEM NUMBER	DESCRIPTION
04123-1401-000	1	HARNESS, CHESSMAN
	2	CHESSMAN COVER
04123-0530-002	3	CHESSMAN HOUSING
04127-0220-001	4	CHESSMAN ROD
00478-0012-005	6	CHESSMAN BUTTON
	E	O-RING 3 1/2 X 3 5/8 X 1/16 TEFL
	G	S.H.C.S. 6-32X1 S/S
20676-1251-000	I	BEARING, SPHERICAL
26628-6003-000	B	RETAINING RING

## Main Head Assy

Part Number: 04123-0405-000

COMPONENT PART	ITEM NUMBER	DESCRIPTION
04123-0410-006	2	DASH POT SUPPORT
	3	SPOTLIGHT HARNESS EXTENSION
04123-0400-001	5	PUSH ROD FOR MAIN HEAD
04123-0410-021	6	DRIVE BELT FOR CAM
04123-7200-009	7	LVDT CORE PIN
04123-0440-006	8	DOUBLE PULLEY, MOTOR DRIVE
	9	MICROSCOPE SUPPORT
	10	HEIGHT CONTROL LINK
04123-0400-003	11	EXTENSION SPRING
00478-5022-004	12	PUSH ROD LOCK NUT (RH)
04123-0450-000	13	BONDING HEAD
	14	HARNESS EXTENSION ILLUMINATOR
	15	FRONT HEAD COVER
	16	RIGHT COVER
	17	LEFT HEAD COVER
04123-1838-000	19	ILLUMINATION ASSY
	20	SPOTLIGHT SUPPORT ST. 303
04123-0410-023	21	CAM PULLEY
	22	CLAMP LIFTER
	23	HEAD BODY

## Main Head Assy (Continued)

COMPONENT PART	ITEM NUMBER	DESCRIPTION
25815-6001-000	A	DASH POT 160A 1.5F 2.25LN
13100-0008-000	E	LAMP, HALOGEN 12V
	J	WASHER, SPRING CURVE 1/4 ID BF
28595-0135-000	L	CORE, LVDT FOR X-DUCER
	O	NUT, HEX 10-32X 11/32 SMALL PAT S/S

## Tool Lifter

Part Number: 04123-0412-000

COMPONENT PART	ITEM NUMBER	DESCRIPTION
	2	CAM FOR TOOL LIFTER
	1	HANDLE-SOLDER ASSY
	4	BEARING

## LVDT Assy

Part Number: 04123-0414-000

COMPONENT PART	ITEM NUMBER	DESCRIPTION
04123-1500-000	1	LVDT AND HARNESS
	3	LVDT HOLDER

## Clamp Lifter

Part Number: 04123-0416-000

COMPONENT PART	ITEM NUMBER	DESCRIPTION
	1	HANDLE SOLDER ASSY
	2	BEARING
	3	HANDLE
	4	ARM
	5	PIN

## Force Actuator Assy

Part Number: 04123-0417-000

COMPONENT PART	ITEM NUMBER	DESCRIPTION
	1	FORCE ACTUATOR HOLDER
	2	COIL AND ACTUATOR ASSY

## Tear and Feed System

Part Number: 04123-0422-000

COMPONENT PART	ITEM NUMBER	DESCRIPTION
	1	AXLE
	2	CAM
	3	PAD
	4	SPRING LOADED CAM

## Tear and Feed System (Continued)

COMPONENT PART	ITEM NUMBER	DESCRIPTION
	5	SPRING
	6	ROTARY HANDLE
	A	NEGATOR SPRING
	B	WASHER, SPRING CURVE 10 ID BF
	E	RING, RETAINING BASIC EXT.

## Spool Support 1/2"

Part Number: 04123-0426-000

COMPONENT PART	ITEM NUMBER	DESCRIPTION
	1	SPOOL PIVOT
	2	SPOOL SUPPORT
	B	WASHER, SPRING CURVE 5 ID BF
20630-6007-000	D	BEARING, MINITURE
	E	NUT, HEX 5-40 SMALL PAT S/S L=3/32

## Bonding Head

Part Number: 04123-0450-000

COMPONENT PART	ITEM NUMBER	DESCRIPTION
	1	BONDING HEAD
	2	DASHPOT CONNECTING ROD (9-13)
04123-0421-005	3	LARGE COUNTERWEIGHT
04123-0421-006	4	FINE BALANCE FOR BONDING HEAD
	5	ECCENTRIC CAM
	6	ROD
04123-0422-000	7	TEAR AND FEED SYSTEM
	8	BEARING BRONZE
04123-0770-000	9	CLAMP ASSY
04123-1102-000	10	CLAMP SOLENOID HARNESS
04123-0450-001	11	CLAMP LINK
04123-0452-000	12	BRACKET ASSY FOR TEAR AND FEED SOLENOID
	13	PAD TURCITE
04123-0426-000	14	SPOOL SUPPORT 1/2"
	15	CONTACT ASSY
04306-0050-000	16	TRANSDUCER, WEDGE BONDER, LONGHORN
04123-0450-003	17	U-BOLT
04123-0450-004	18	SPACER

## Bonding Head (Continued)

COMPONENT PART	ITEM NUMBER	DESCRIPTION
20604-1029-000	N	BEARING, ANGULAR CONTACT FLANGE
29010-6032-000	P	BALL BEARING 1/4 DIA.

## Bracket Assy for Tear and Feed Solenoid

Part Number: 04123-0452-000

COMPONENT PART	ITEM NUMBER	DESCRIPTION
	1	BRACKET FOR TEAR AND FEED SYS
	2	NUT SS 303, FOR TEAR & FEED SYS
	3	FRICITION DISK
04123-0790-001	4	SOLENOID BUSHING
04123-0425-001	5	CONSTANT FORCE SPRING HANGER FOR TEAR & FEED SYS
04123-0425-002	6	SPRING HOLDER
04123-0425-003	7	SOLENOID BUSHING
04123-1710-000	8	ZERO SOLENOID
04123-1720-000	9	TEAR SOLENOID
	10	PIVOT
04123-0790-003	11	CONTACT SPACER
	B	WASHER, WAVE .265X.367 X.006S/S



## Height Control Link

Part Number: 04123-0455-000

COMPONENT PART	ITEM NUMBER	DESCRIPTION
	2	LINK
04123-0411-003	4	SCREW FOR HEIGHT CONTROL LINK
04123-1885-000	5	LINK GROUND CABLE
00478-0555-000	6	ROD END ASSY (RH)
20647-1053-000	C	BEARING, RADIAL BALL
	D	B.H.C.S. 5-40 X 1/2 CP
		B.H.C.S. 5-40 X 1/2L SS
20630-1030-000	E	BEARING, MINIATURE

## Coil and Actuator Assy

Part Number: 04123-1920-000

COMPONENT PART	ITEM NUMBER	DESCRIPTION
		ACTUATOR ASSY
04123-1900-000	1	COIL HARNESS
	A	MAGNET FORCE ACTUATOR

**Mother Board****Part Number: 04123-4320-000**

COMPONENT PART	ITEM NUMBER	DESCRIPTION
	1	MOTHER BOARD
18538-6065-000	F1-F4	FUSE SLOW BLOW MINI 250V 2.5A
	G	VARISTOR 50 VRMS 1 KA
	K	RESISTOR WW 1 OHM 3W 1%

**Manual Z (Optional)****Part Number: 04123-7200-000**

COMPONENT PART	ITEM NUMBER	DESCRIPTION
04123-0414-000	4	LVDT ASSY
	6	MANUAL Z KIT
	15	FINGER TAB
04123-1510-000	16	PHOTOCELL HARNESS ASSY
04123-7200-012	18	EXTENSION SPRING FOR MANUAL Z

## Manual Z Kit

Part Number: 04123-7210-000

COMPONENT PART	ITEM NUMBER	DESCRIPTION
00478-0555-000	1	ROD END ASSY (RH)
00478-5022-004	2	PUSH ROD LOCK NUT (RH) FOR MANUAL Z
	4	Z LEVER (MACH)
	5	AXLE
	6	AXLE SUPPORT
04123-7200-007	7	PUSH ROD
	8	PHOTOCELL FLAG
04123-7200-009	9	LVDT CORE PIN
	10	TORSION SPRING FOR MANUAL Z
	11	LEVER
	12	WASHER
	13	BUSHING
28595-0135-000	Q	CORE, LVDT FOR X-DUCER

## Spotlight Assy

Part Number: 04123-7300-000

COMPONENT PART	ITEM NUMBER	DESCRIPTION
04123-0810-002	1	SPOTLIGHT HOUSING
	3	X-Y ADJUSTING SCREW
	4	SCREW TIP
	5	CONE ADJ. SCREW MOLD ASSY
00478-5019-004	6	SPRING, SPOTLIGHT HOLDER
04123-1840-000	7	HARNESS, SPOTLIGHT ASSY
	8	PIVOT, SPOTLIGHT
	9	SPOTLIGHT ROLL ASSY
22110-2554-001	C	COUPLING, BELLOWS NLY FC-15
12933-5424-000		LAMP

## Manipulator

Part Number: 04124-0212-000

COMPONENT PART	ITEM NUMBER	DESCRIPTION
	1	MANIPULATOR
04123-0214-000	2	LEVER ASSY
	3	X-Y FRAME
04123-0211-002	4	GROOVED ROLLER
	5	SPACER
	6	SHOULDER SCREW
04123-0212-003	7	SPRING
	8	BALL RETAINER
00484-0001-014	9	BALL RACE WAY
20647-1118-000	A	BEARING, RADIAL BALL FLANGE
20676-1251-000	C	BEARING, SPHERICAL

## Head Body

Part Number: 04124-0410-000

COMPONENT PART	ITEM NUMBER	DESCRIPTION
	2	BEARING SUPPORT
	4	PIN FOR TOOL LIFTER
	5	CAM SHAFT
04123-0410-012	7	COVER PIVOT
	9	LEFT COVER BRACKET
	10	TOOL LIFTER
04123-0417-000	11	FORCE ACTUATOR ASSY
04123-0414-000	12	LVDT ASSY
	13	BEARING SCREW SUPPORT
	14	LINK PIVOT S.S. 303
	16	RIGHT COVER BRACKET
	18	HEAD FRAME
	19	NUT
04123-1600-000	21	MOTOR TACHO HARNESS
20647-6032-000	A	BEARING, RADIAL BALL FLANGED
20604-1028-000	0	BEARING, ANGULAR CONTACT
	T	S.H.C.S. 10-24x3/4 CP

**Harness, Chessman****Part Number: 04123-1401-000**

COMPONENT PART	ITEM NUMBER	DESCRIPTION
-----		
00488-1000-006	1	SWITCH, CHESSMAN ELECTRONIC
15850-6027-000	F	SWITCH, PUSHBUTTON SPDT

**Microscope Holder****Part Number: 04123-0350-000**

COMPONENT PART	ITEM NUMBER	DESCRIPTION
-----		
	2	MICRO BRACKET
	3	PIN FOR MICROSCOPE HOLDER
	A	ARM, STATIONARY

## Maintenance Tool Kit

Part Number: 04123-0910-000

COMPONENT PART	ITEM NUMBER	DESCRIPTION
04123-0910-001	1	SQUARE BLOCK
04123-0910-002	2	ANGLE BLOCK
04123-0910-003	3	ROD (VERTICALITY PIN)
04123-6000-008	4	WEDGE, GAUGE #828
04123-6000-008	5	WEDGE, GAUGE #750
04124-6000-002	6	SET UP GAUGE
27776-2333-000	A	WRENCH, ALLEN 9050
27776-6000-000	B	WRENCH, ALLEN .035



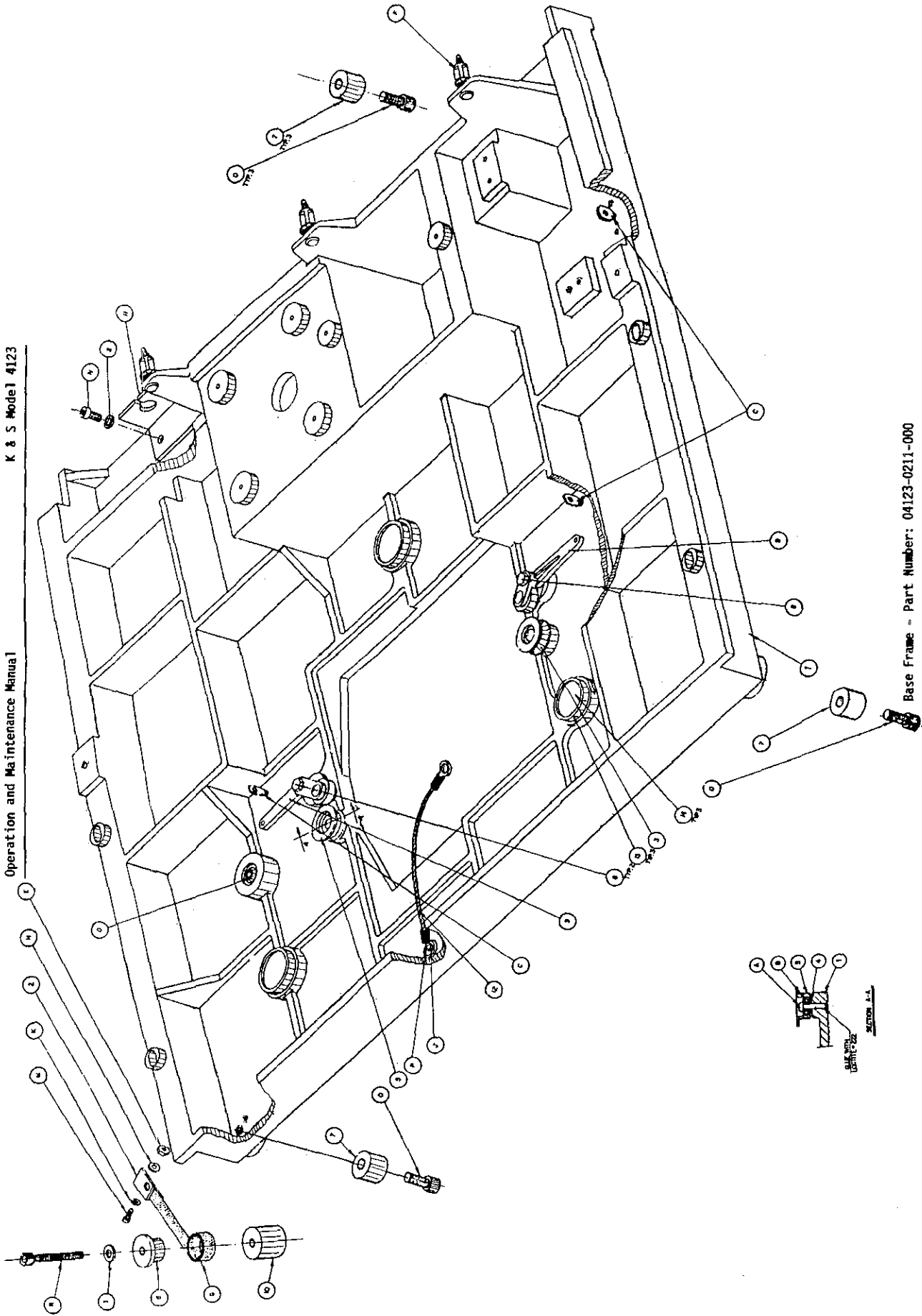

Base Frame - Part Number: 04123-0211-000

FRONT VIEW

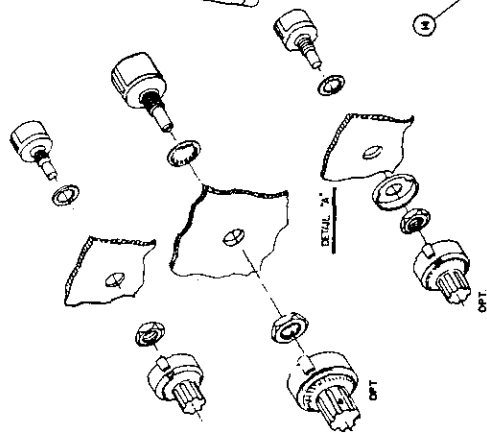
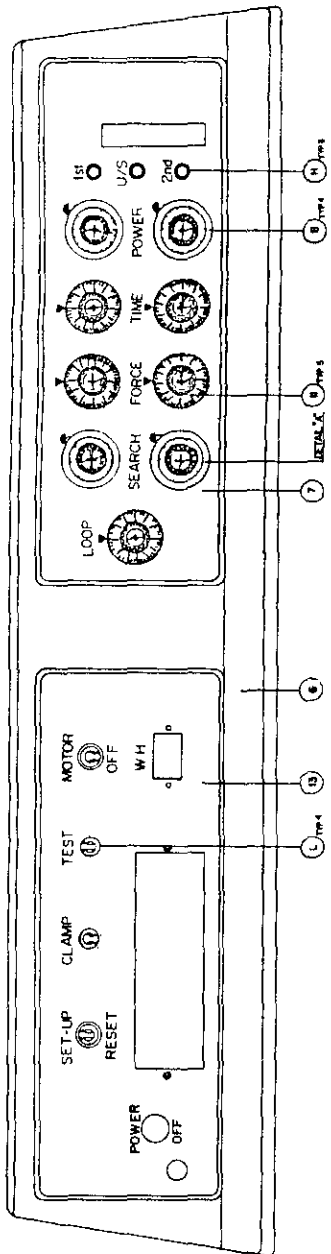

REAR VIEW

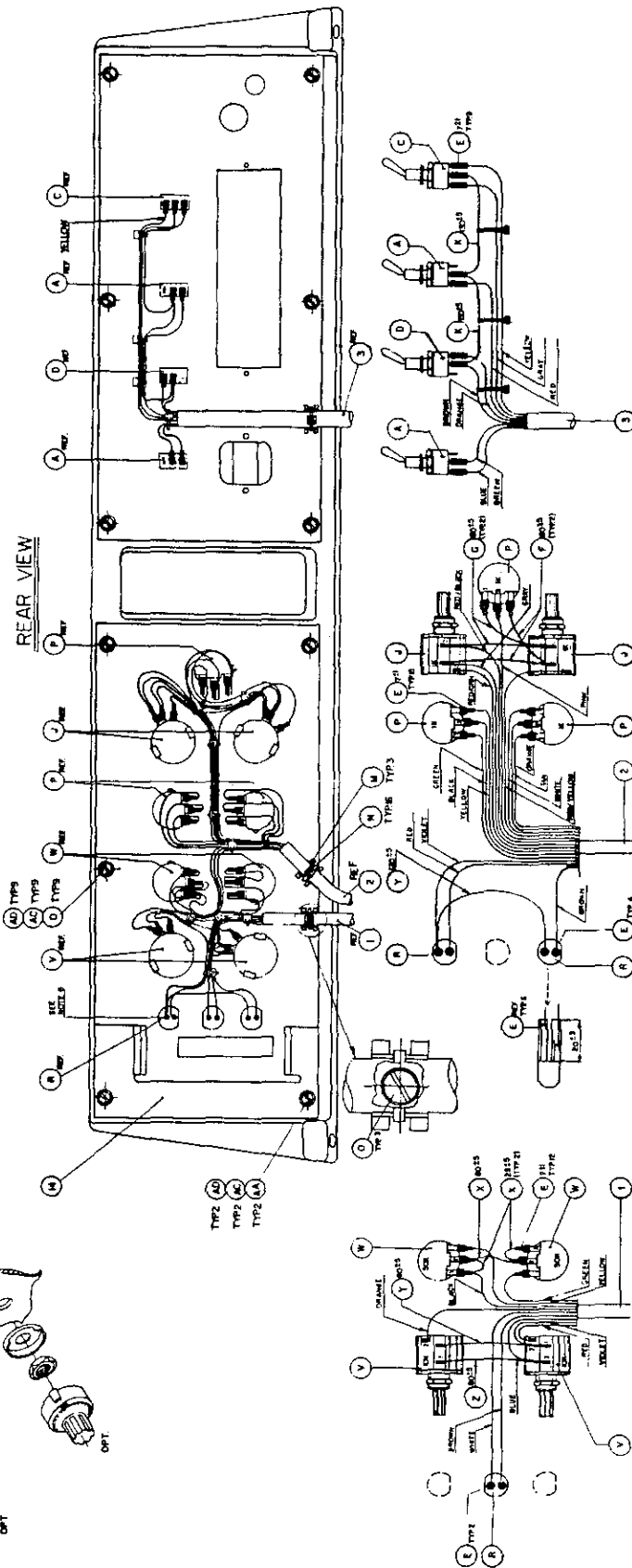

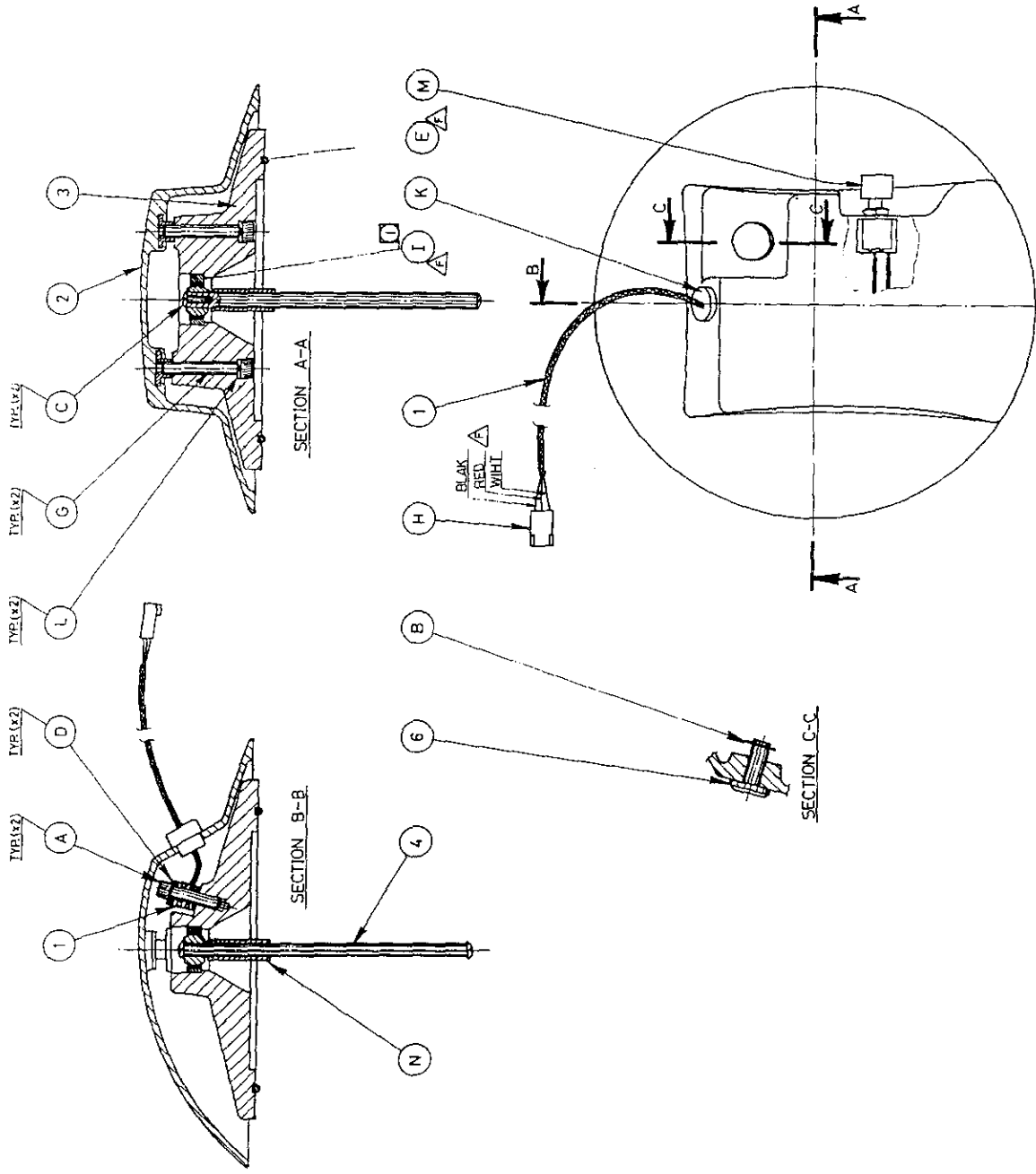

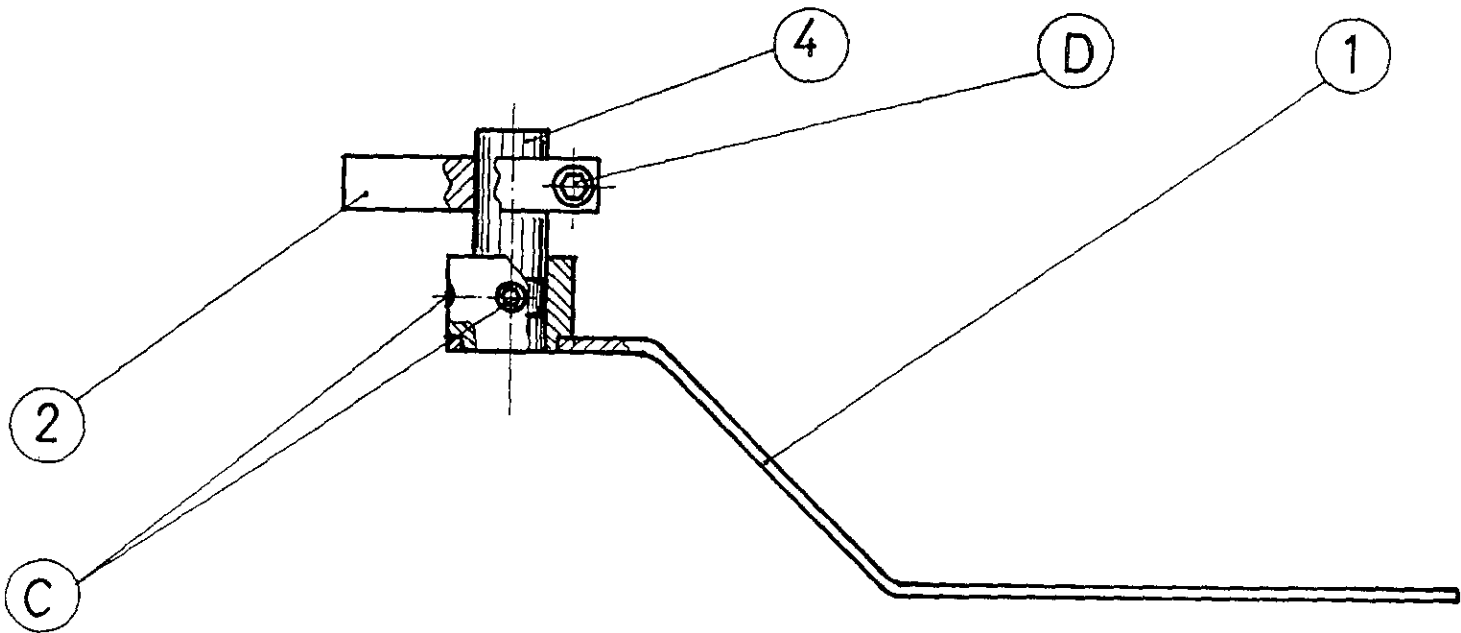

Tool Lifter - Part Number: 04123-0412-000

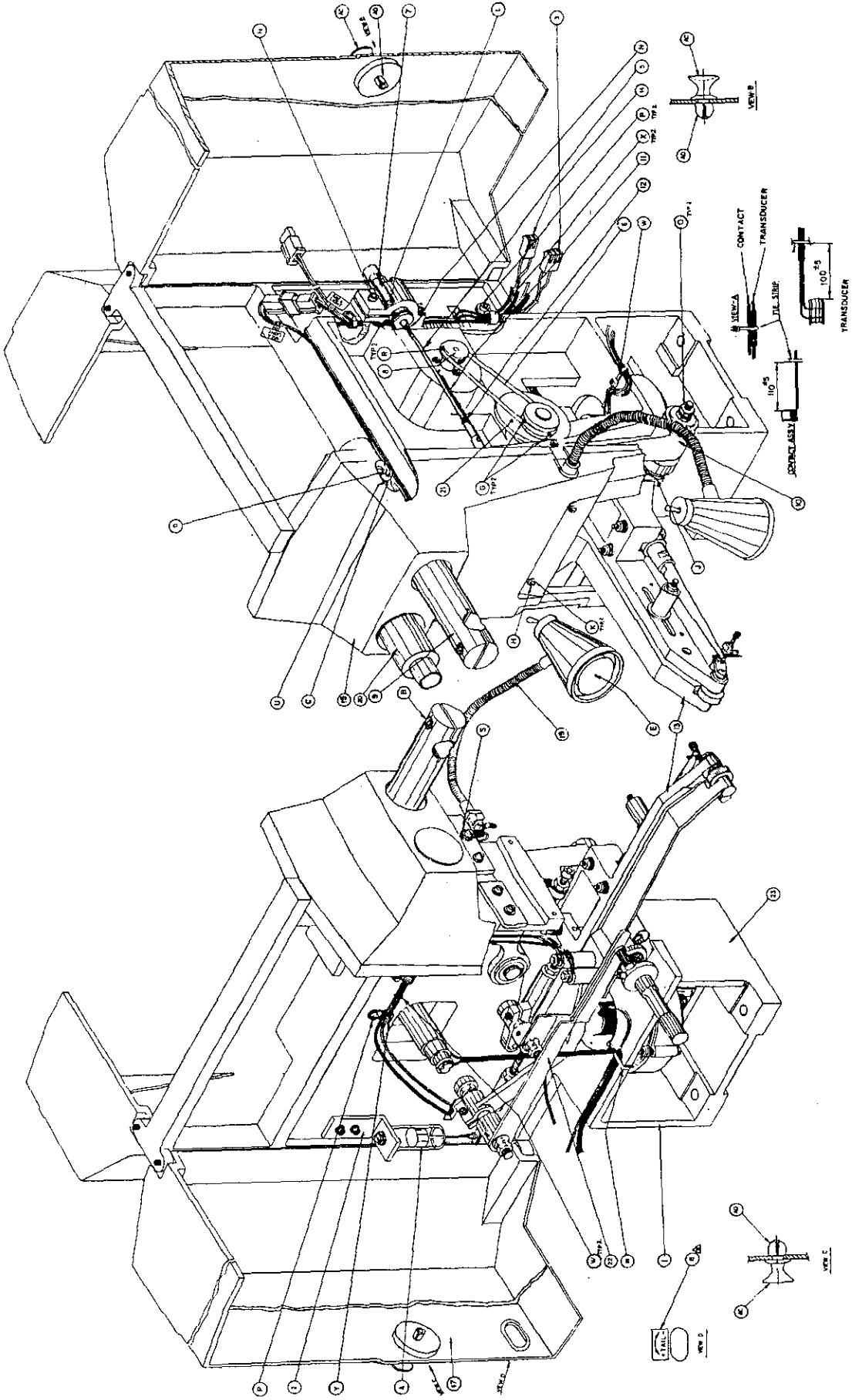

Main Head Assy - Part Number: 04123-0405-000

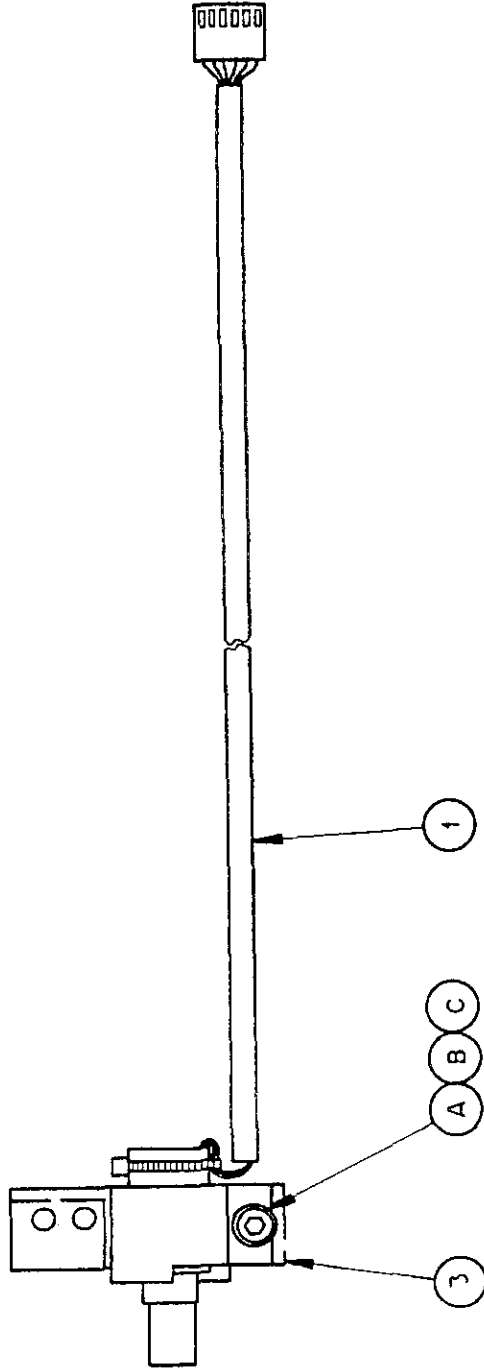

LVDT Assy - Part Number: 04123-0414-000

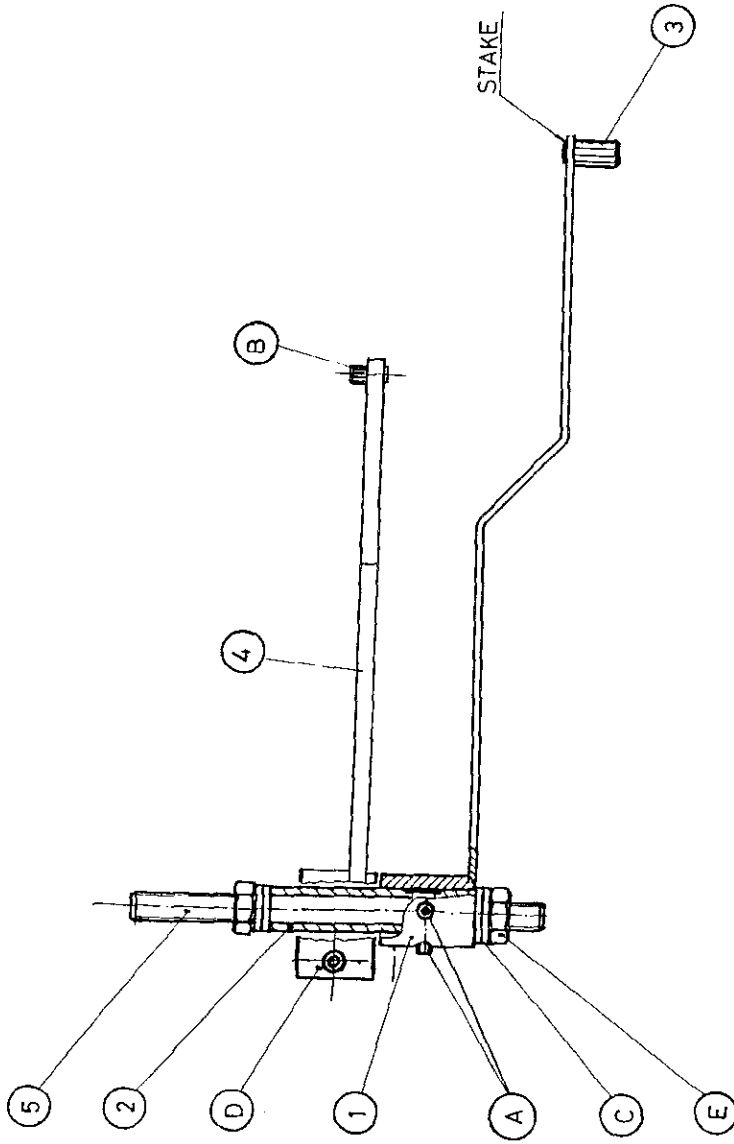

Clamp Lifter - Part Number: 04123-0416-000

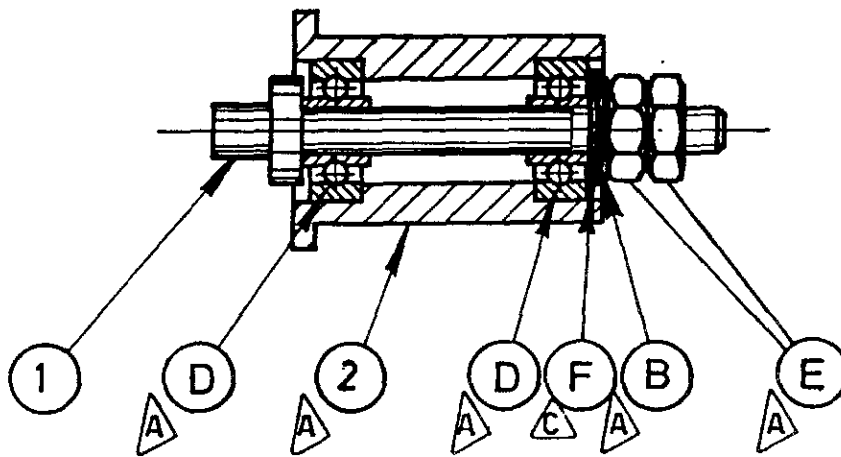

Spool Support 1/2" - Part Number: 04123-0426-000



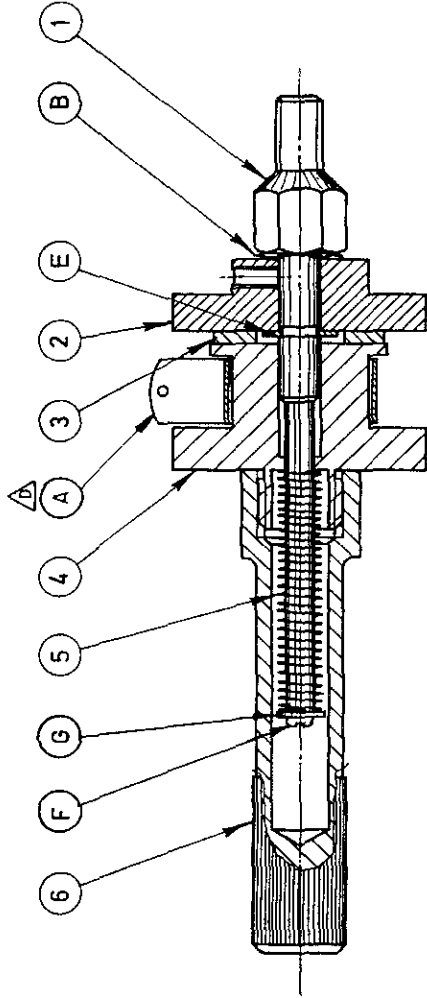

Tear and Feed System - Part Number: 04123-0422-000

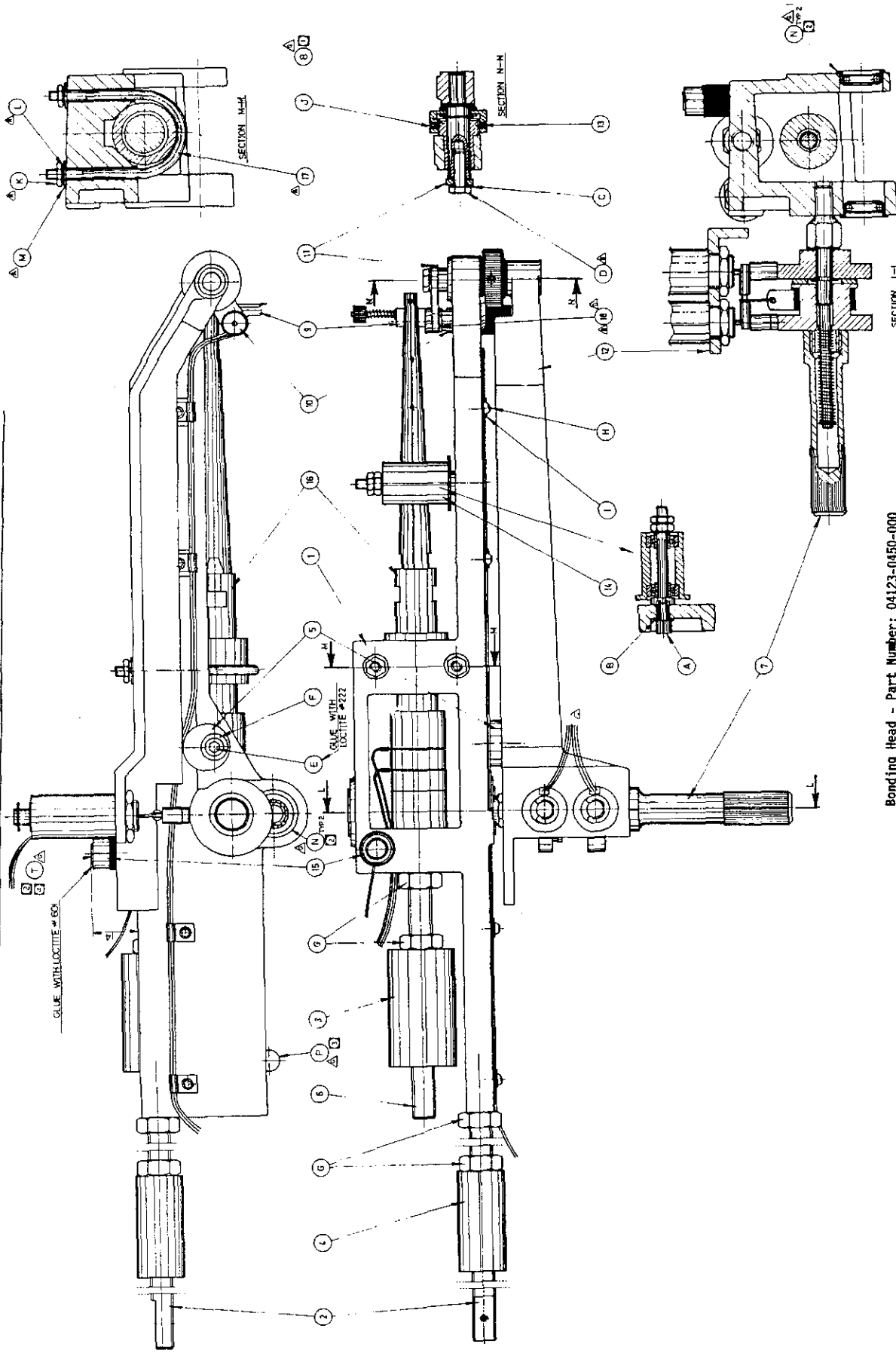

Bonding Head - Part Number: 04123-0450-000

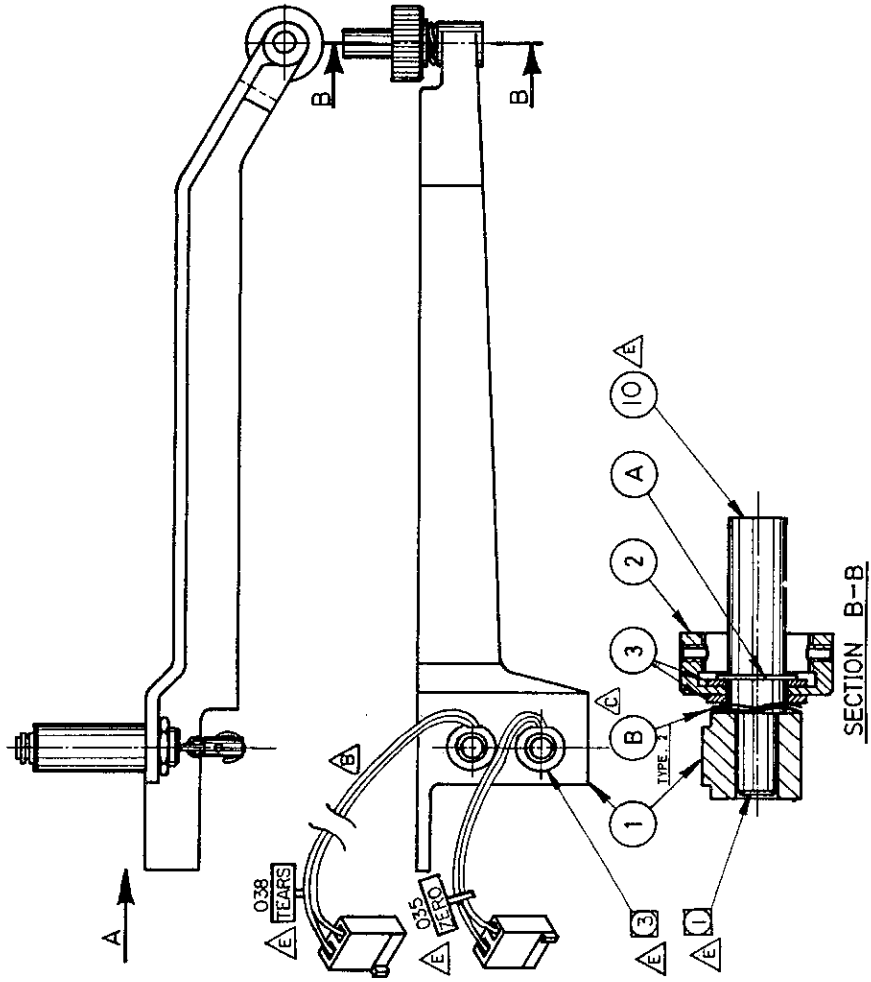
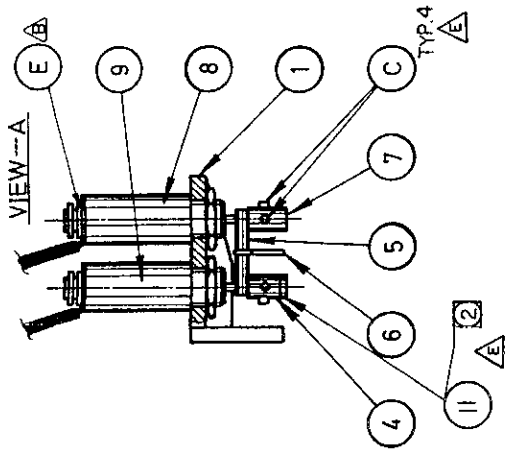

Bracket Assy for Tear and Feed Solenoid -- Part Number: 04123-0452-000

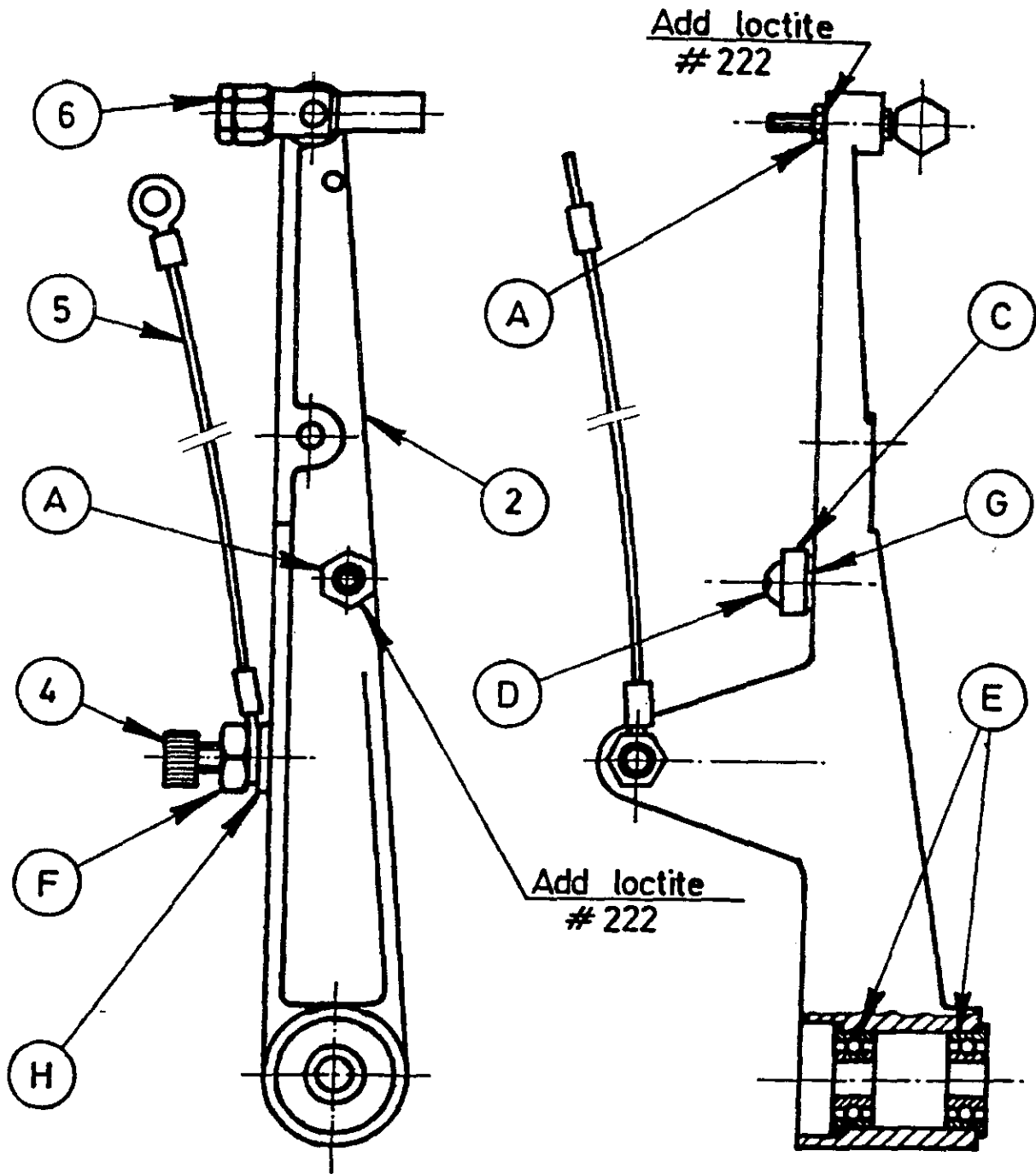

Height Control Link - Part Number: 04123-0455-000

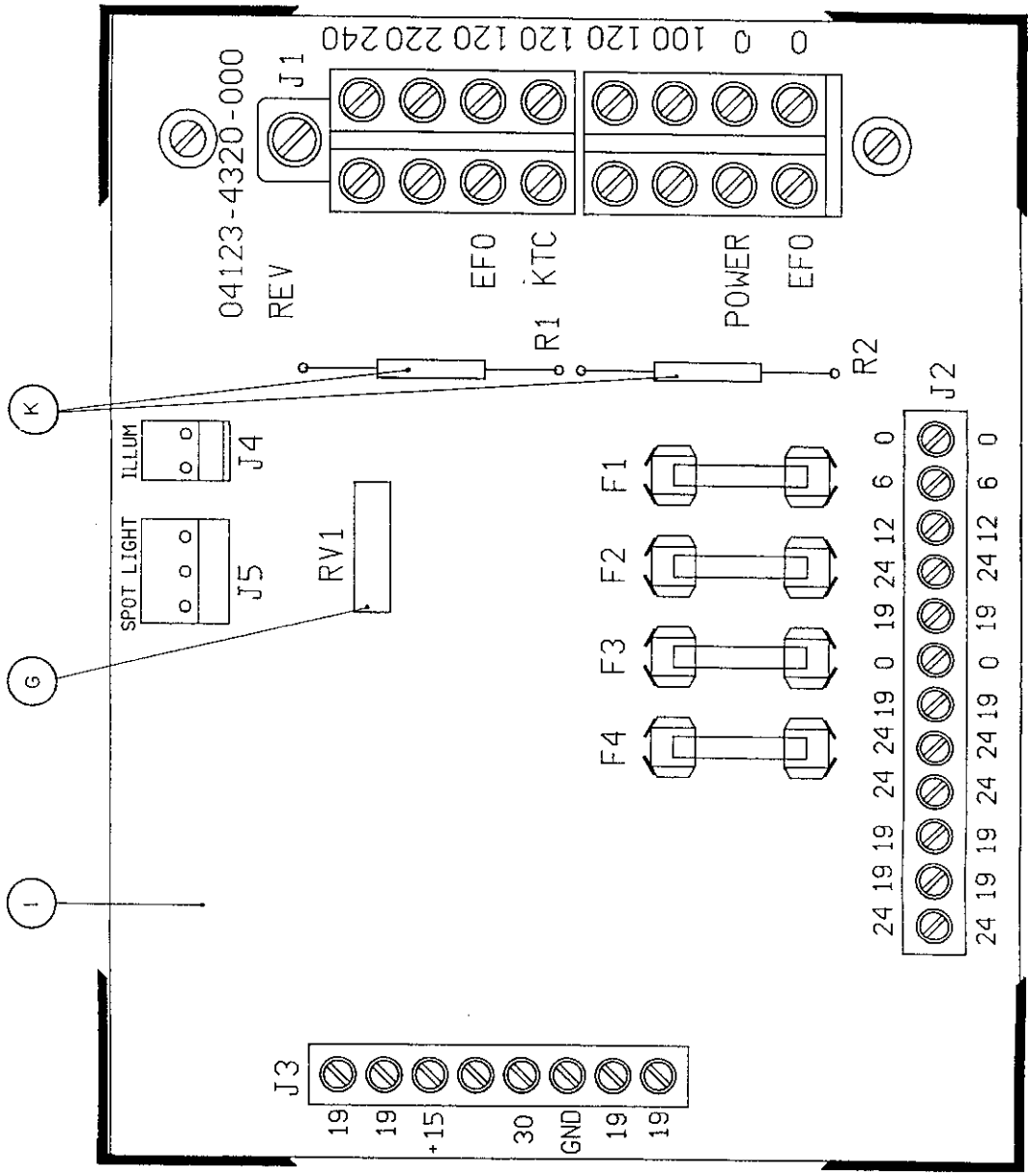

Mother Board - Part Number: 04123-4320-000

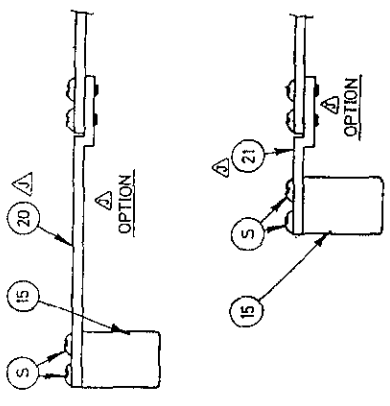
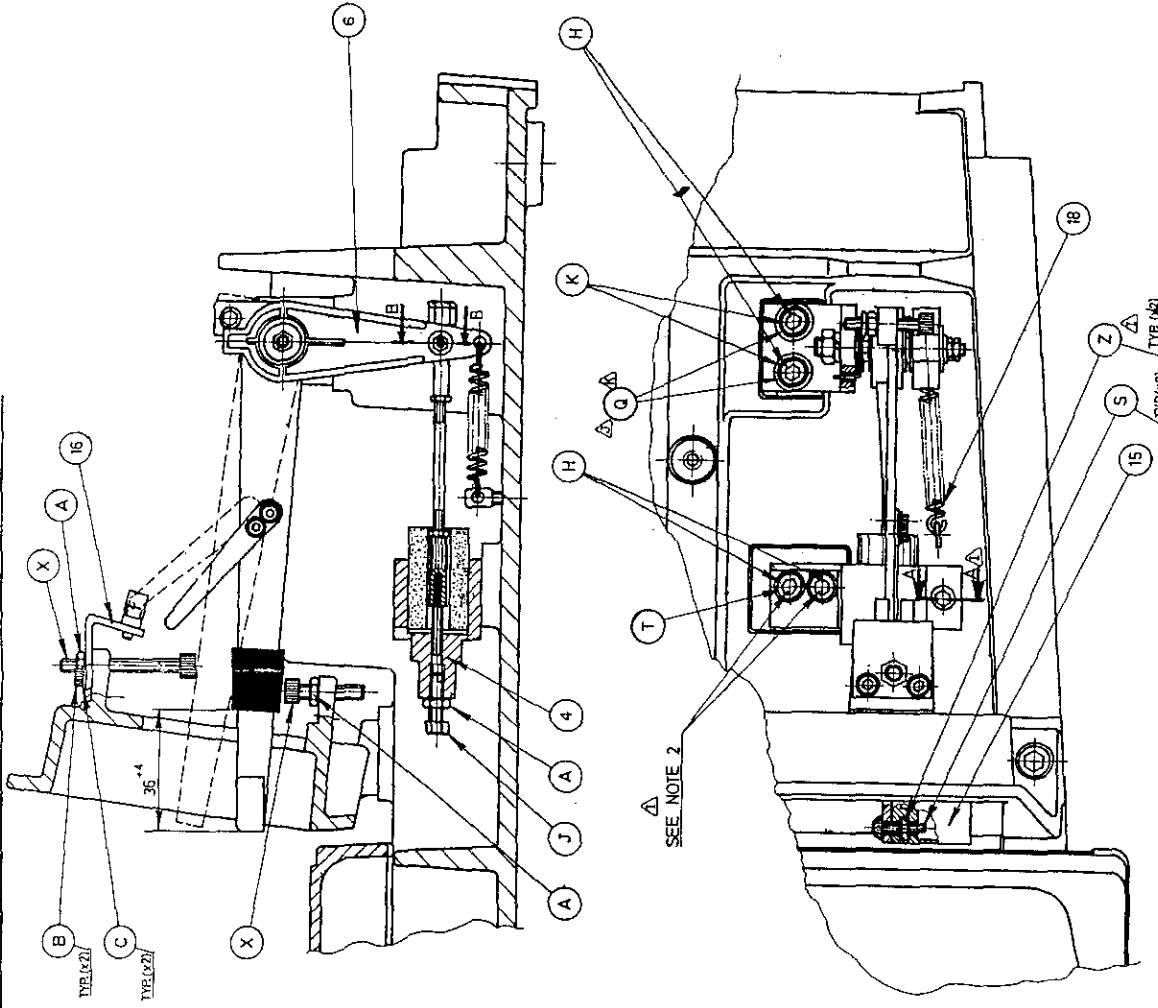

Manual Z (Optional) - Part Number: 04123-7200-000

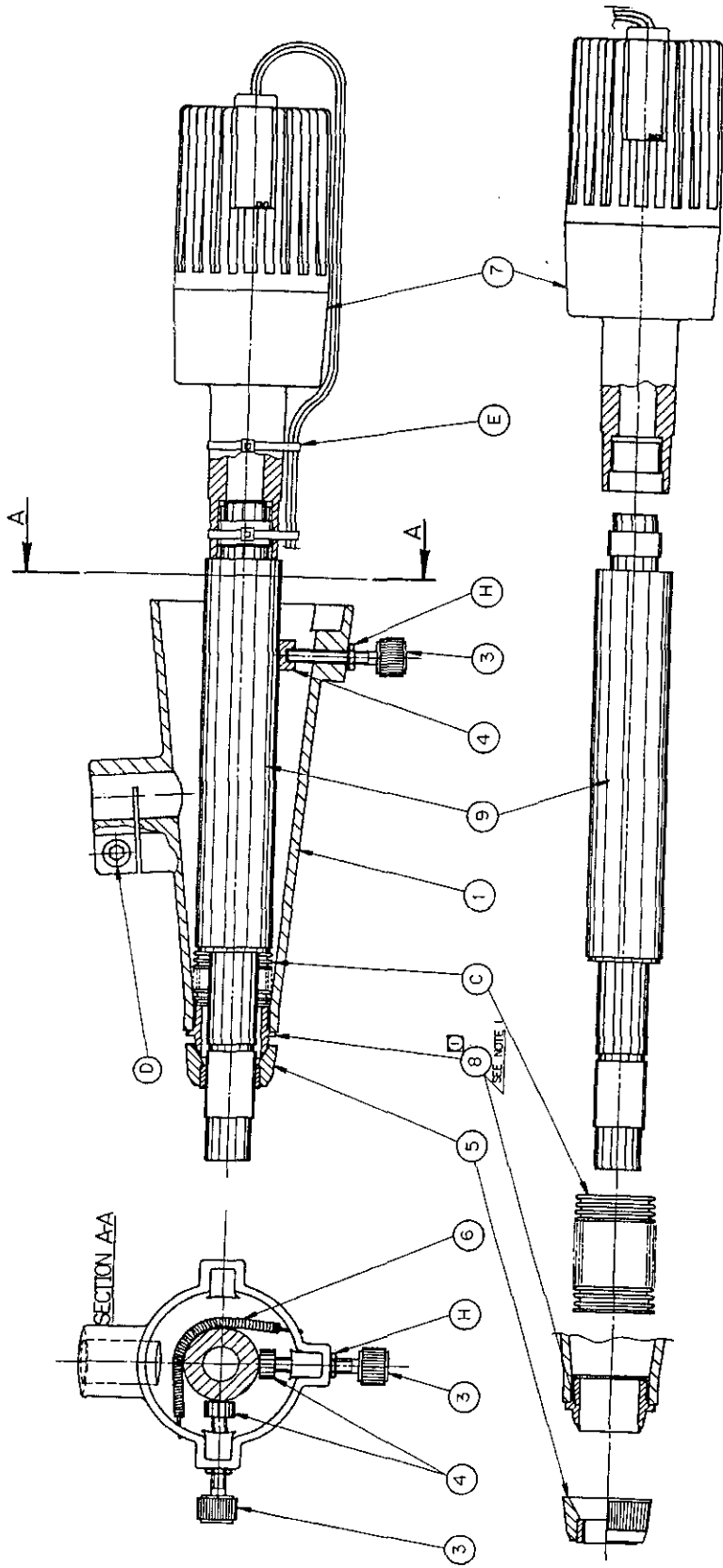

Spotlight Assy - Part Number: 04123-7300-000

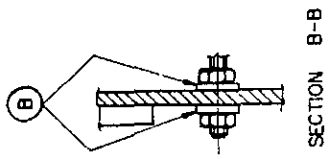
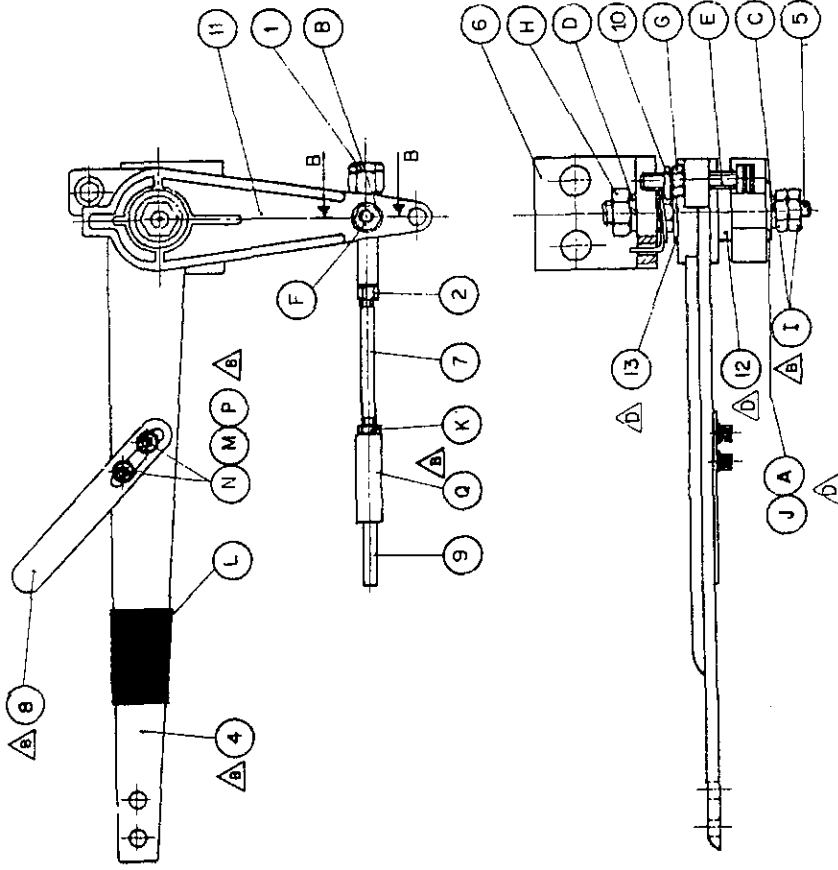

Manual Z Kit - Part Number: 04123-7210-000



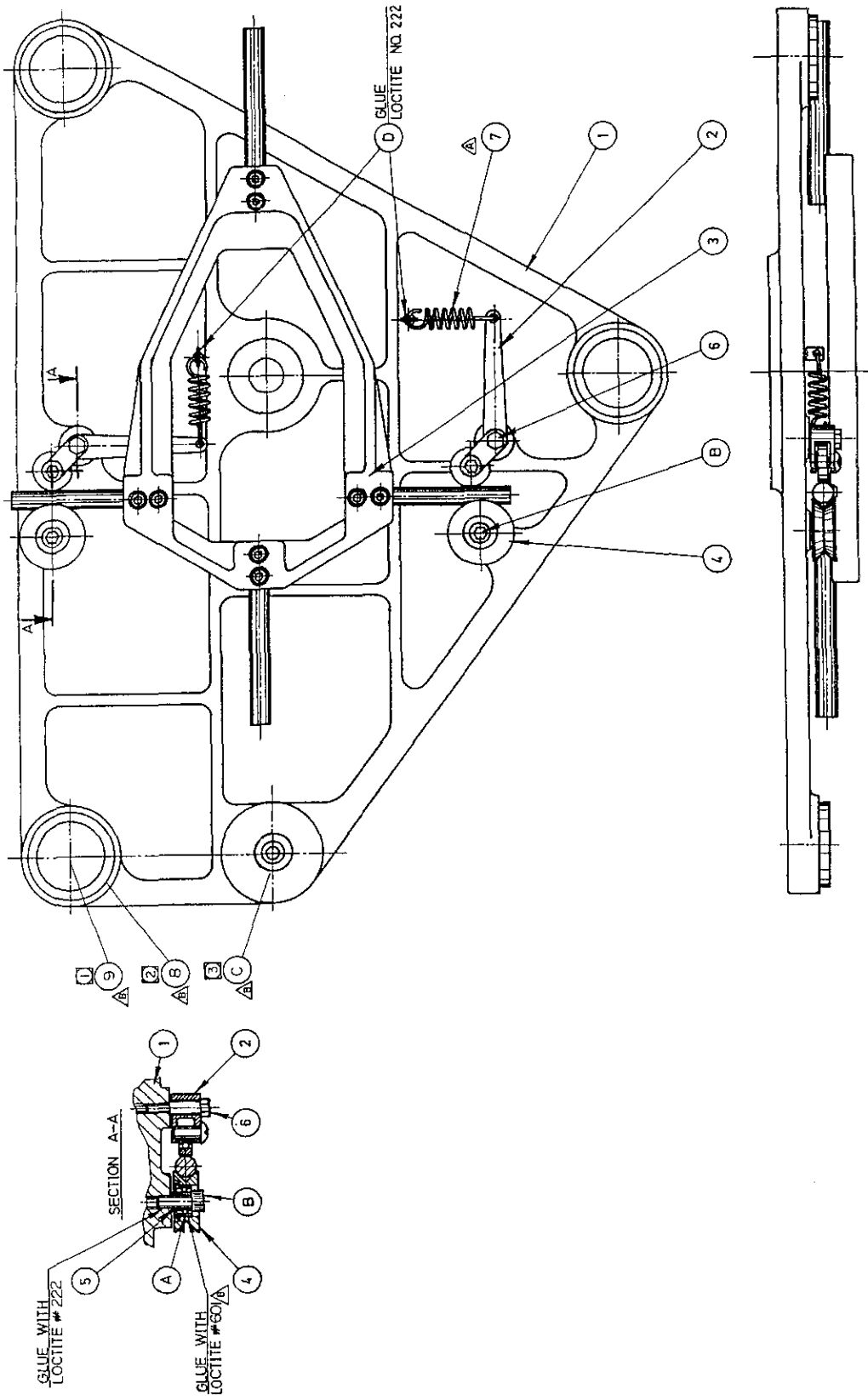

Manipulator - Part Number: 04124-0212-000

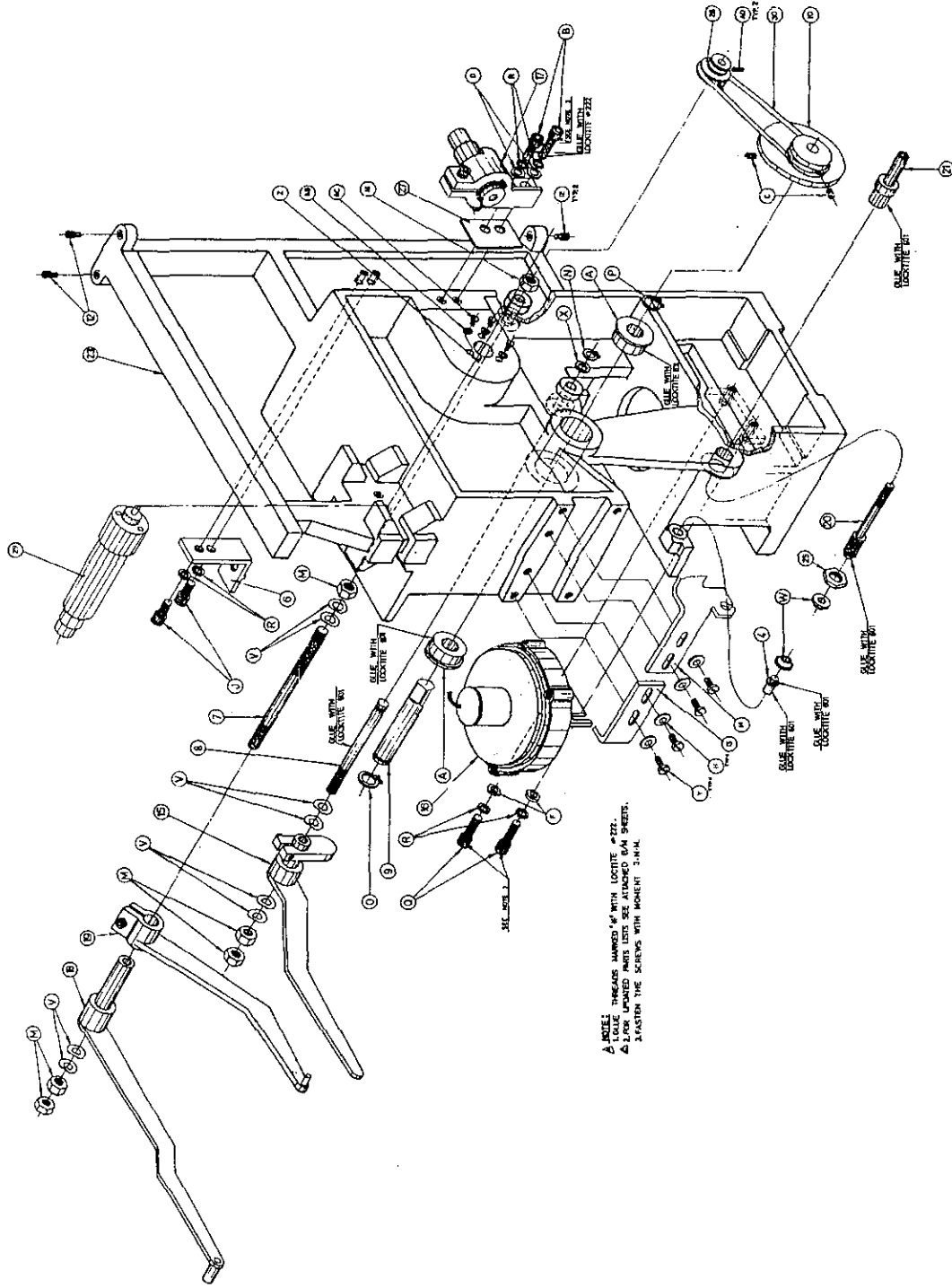

▲ HOLES THROUGH JAWED 1/4" WITH LOCITE #22.  
▲ LAR UPATED PARTS SEE ATTACHED B/A SHEETS.  
▲ FASTEN THE SCREWS WITH MOMENT 3.0-4.0.

Head Body 04123-0410 00

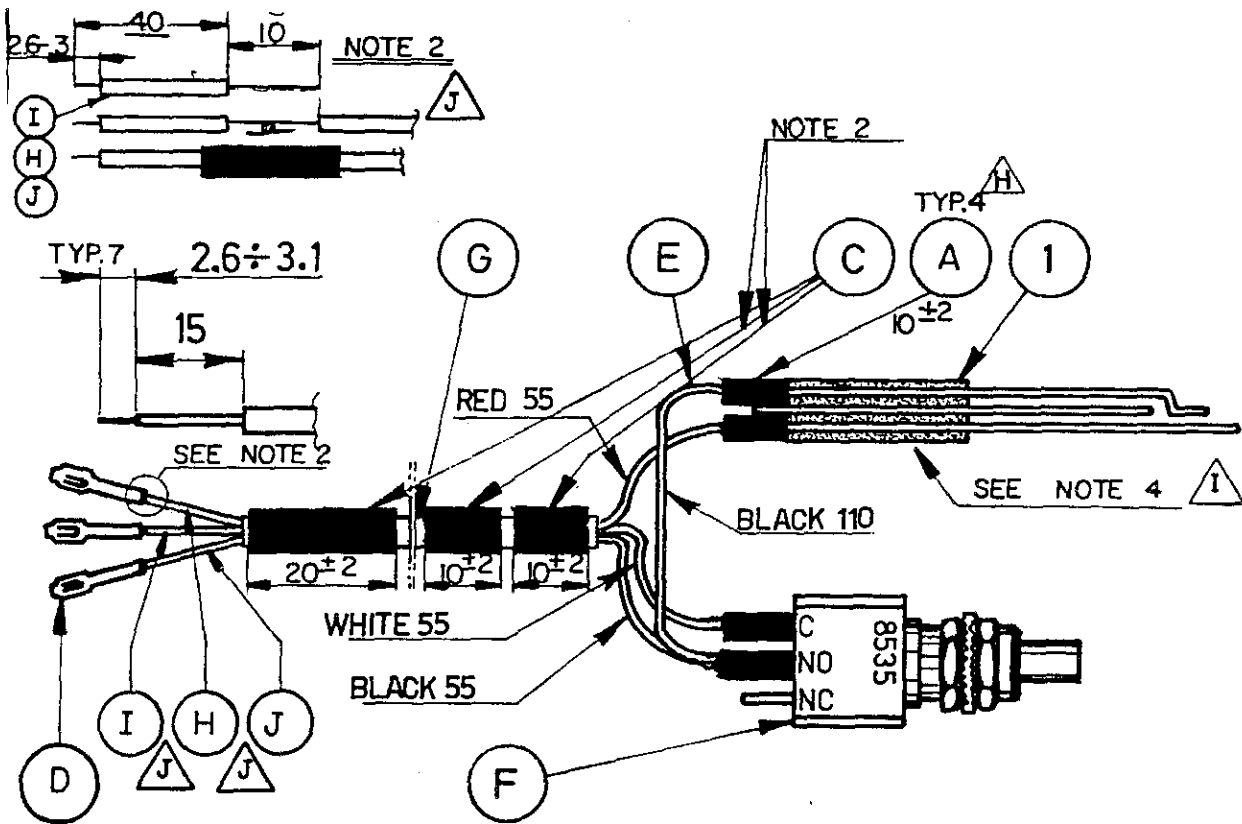

Harness, Chessman - Part Number: 04123-1401-000

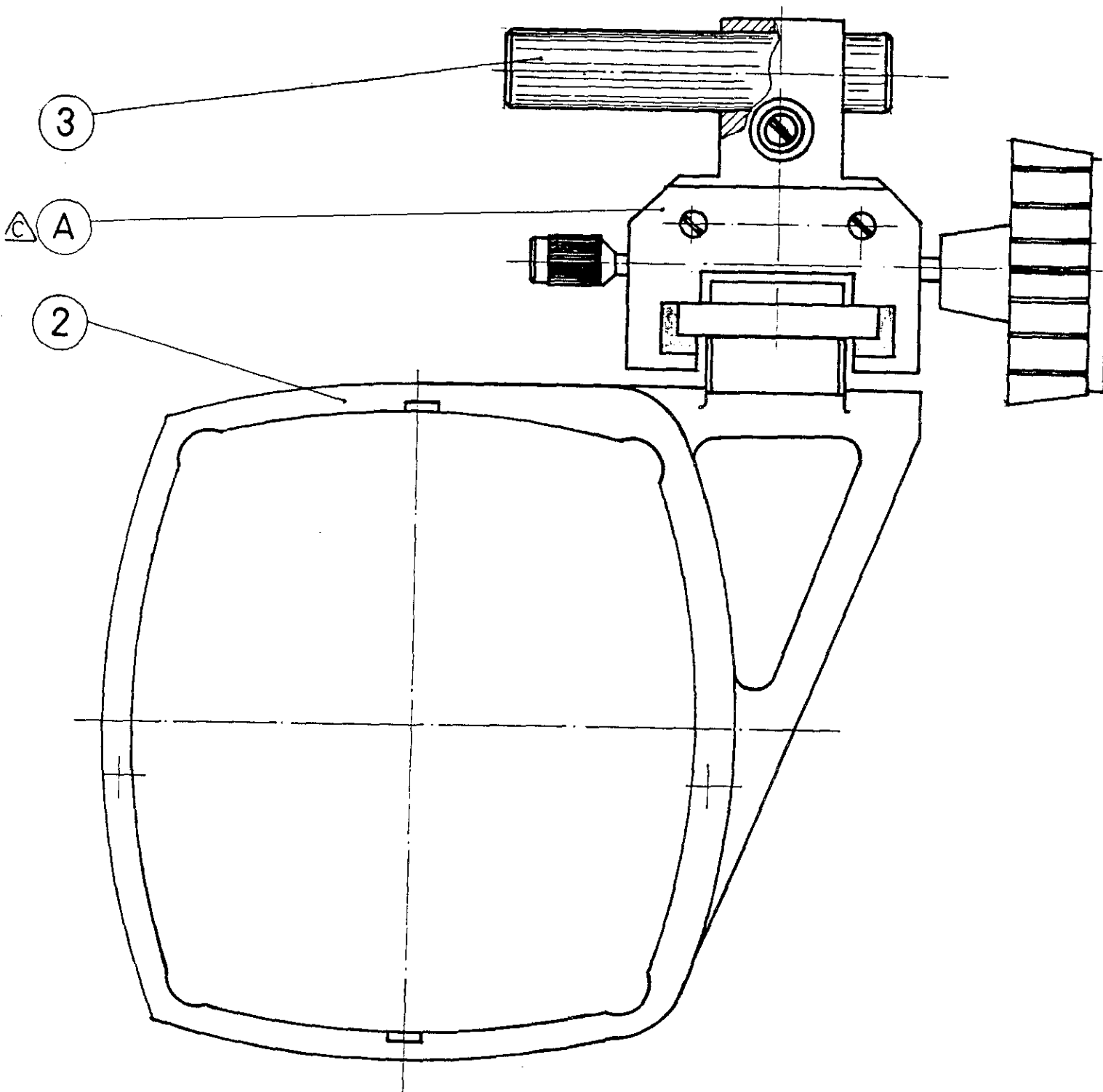

Microscope Holder - Part Number: 04123-0350-000

ECN	REV	APP
880250	A	
880014	B	
880092	C	
880160	D	
880057	E	PALETTA
880019	F	P. RIZZI
880249	G	E. CL.

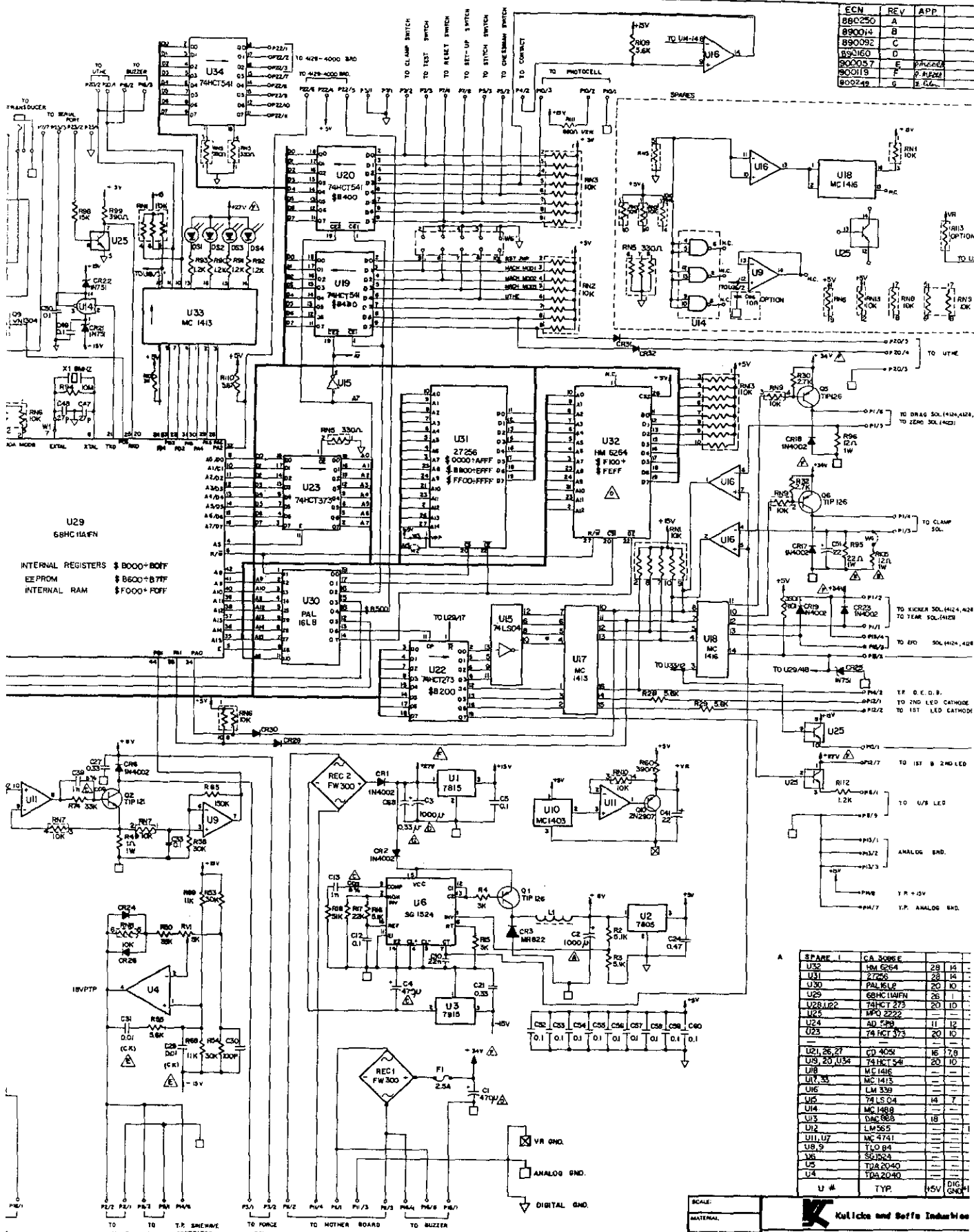

INTERNAL REGISTERS \$B000-\$B0FF  
 EEPROM \$B600-\$B7FF  
 INTERNAL RAM \$F000-\$F0FF

U #	GA	QTY	REV	APP
U29	68HC11AFN	1		
U30	PAL16L8	1		
U31	74HC13	1		
U32	74HC154	1		
U33	MC1413	1		
U34	74HC154	1		
U35	74HC13	1		
U36	74HC154	1		
U37	74HC13	1		
U38	74HC154	1		
U39	74HC13	1		
U40	74HC154	1		
U41	74HC13	1		
U42	74HC154	1		
U43	74HC13	1		
U44	74HC154	1		
U45	74HC13	1		
U46	74HC154	1		
U47	74HC13	1		
U48	74HC154	1		
U49	74HC13	1		
U50	74HC154	1		
U51	74HC13	1		
U52	74HC154	1		
U53	74HC13	1		
U54	74HC154	1		
U55	74HC13	1		
U56	74HC154	1		
U57	74HC13	1		
U58	74HC154	1		
U59	74HC13	1		
U60	74HC154	1		
U61	74HC13	1		
U62	74HC154	1		
U63	74HC13	1		
U64	74HC154	1		
U65	74HC13	1		
U66	74HC154	1		
U67	74HC13	1		
U68	74HC154	1		
U69	74HC13	1		
U70	74HC154	1		
U71	74HC13	1		
U72	74HC154	1		
U73	74HC13	1		
U74	74HC154	1		
U75	74HC13	1		
U76	74HC154	1		
U77	74HC13	1		
U78	74HC154	1		
U79	74HC13	1		
U80	74HC154	1		
U81	74HC13	1		
U82	74HC154	1		
U83	74HC13	1		
U84	74HC154	1		
U85	74HC13	1		
U86	74HC154	1		
U87	74HC13	1		
U88	74HC154	1		
U89	74HC13	1		
U90	74HC154	1		
U91	74HC13	1		
U92	74HC154	1		
U93	74HC13	1		
U94	74HC154	1		
U95	74HC13	1		
U96	74HC154	1		
U97	74HC13	1		
U98	74HC154	1		
U99	74HC13	1		
U100	74HC154	1		

NOTES 1. ALL RESISTORS ARE 1/4WATT 5% ALL DIODE ARE IN94  
 UNLESS OTHERWISE SPECIFIED

SCALE:	
MATERIAL:	
HEAT TREATMENT:	Name of drawing
FINISH:	
Drawing No.	SC 4125-4101-000-56
Rev.	

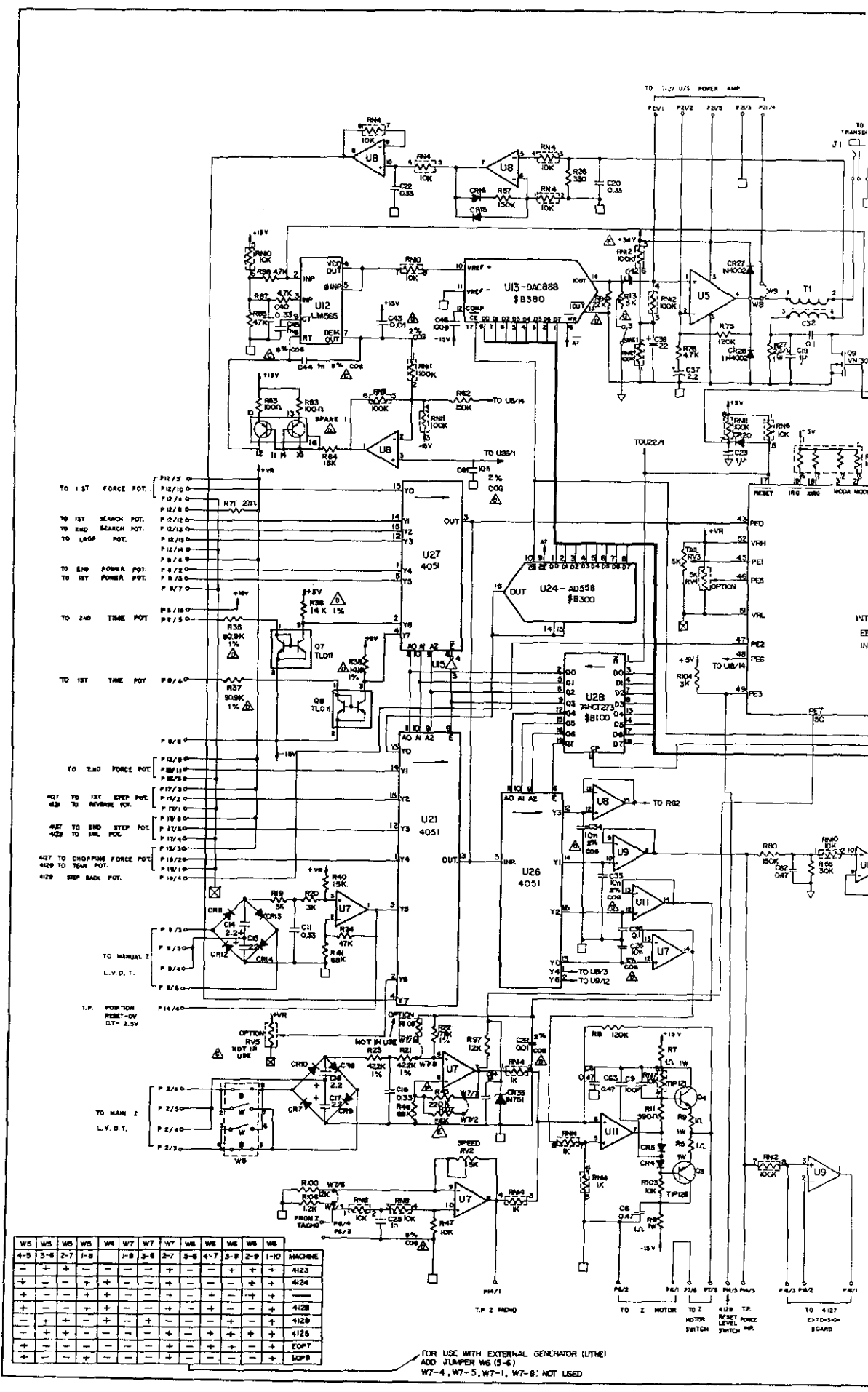

WS	WS	WS	WS	WS	WS	WS	WS	WS	WS	WS	MACHINE
4-5	5-6	2-7	1-8	1-8	3-8	2-7	5-8	4-7	3-8	2-9	4123
-	-	-	-	-	-	-	-	-	-	-	4124
+	-	+	+	+	+	+	+	+	+	+	4125
-	-	-	-	-	-	-	-	-	-	-	4126
+	+	+	+	+	+	+	+	+	+	+	4127
-	-	-	-	-	-	-	-	-	-	-	4128
+	+	+	+	+	+	+	+	+	+	+	EQP7
-	-	-	-	-	-	-	-	-	-	-	EQP8

FOR USE WITH EXTERNAL GENERATOR (LITHE)  
 ADD JUMPER W6 (5-6)  
 W7-4, W7-5, W7-1, W7-8: NOT USED