

---

**Operation and Maintenance Manual**

**for the**

**Gasguard<sup>®</sup> 450**

**Automatic Gas Cabinet and Purge Panel**

**System for Hazardous Cylinder Gases**

**Commodity Number: 809-602775B**

**Revision B: April 4, 1995**

---

Air Products and Chemicals, Inc.  
1919 Vultee Street  
Allentown, PA 18103



# Operation and Maintenance Manual Matrix Sheet for the Gasguard® 450 Automatic Gas Cabinet and Purge Panel Systems

Commodity Number: 809-602775B, Revision B: April 1995

<b>Manual Section</b>	<b>Revision Level</b>	<b>Reason for Revision</b>
Cover and Front	B	General Revision
Introduction	B	General Revision
Section 1: Safety	B	General Revision
Section 2: System Description	B	General Revision
Section 3: Operating Procedures	B	General Revision
Section 4: Troubleshooting	B	General Revision
Section 5: Maintenance	B	General Revision
Section 6: System Specific Information	B	General Revision

## Important Safety Information

Read and understand the safety section found on pages 1-1 to 1-30 of this manual before working with the system. Failure to do so can result in *personal injury or death*.

### Warnings:

Warnings, like the sample shown below are found *throughout* the manual to point out hazards which could cause *personal injury or death* if proper procedures are not followed:



*The operator MUST read and understand the safety section before operating the system. All operating and maintenance personnel must receive training and instruction by Air Products and Chemicals, Inc.*

### System Hazards:

Possible hazards when working with this system are exposure to:

- Toxic Gas Hazards
- Corrosive Gas Hazards
- Flammable Gas Hazards
- Oxidizer Hazards
- Inert Gas Hazards
- Pressurized Gases
- Cylinder Handling Hazards
- Electrical Hazard



*Do not make any changes to the equipment independently. Injury or death may result from unauthorized modifications. If equipment needs to be modified, an Air Products' Representative MUST be contacted.*

## **Air Products Support Systems**

### **Emergency Response - 24 Hour Service**

If an emergency occurs that cannot be alleviated by the trained operator or his/her supervisor, call Air Products and Chemicals, Inc. on one of these telephone numbers.

- From anywhere in the continental United States, Canada and Puerto Rico - 800-523-9374 (toll free)
- From all other locations - 610-481-7711
- FAX -610-481-3772
- APCI Operator - 610-481-4911
- European Community/Middle East Gases - (32)(73)32.949

### **Technical Support - Normal Operation 8:00 a.m. to 5:00 p.m. E.S.T.**

**USA:** Air Products and Chemicals, Inc. 610-481-3706  
Semiconductor Equipment Manufacturing Center  
1919 Vultee Street  
Allentown, PA 18103

#### **Regions:**

**East** Air Products and Chemicals, Inc. 610-481-2628  
A5-2-2  
7201 Hamilton Boulevard  
Allentown, PA 18195-1501

**Mid-America** Air Products and Chemicals, Inc. 512-892-7772  
5341 Industrial Oaks Boulevard  
Austin, Texas 78735-8811

**Southwest** Air Products and Chemicals, Inc. 602-813-8430  
150 E. Alamo Street, Suite #9 (alternate 602-968-4494)  
Chandler, Arizona 85225

**West** Air Products and Chemicals, Inc. 408-453-2432  
2186 Paragon Drive  
San Jose, California 95131

**Technical Support - Normal Operation 08:00 to 17:00, except  
Friday 08:00 to 16:30  
European Community**

Air Products and Chemicals, Inc. (32)-2-725.95.80  
The Equipment Centre  
Leuvnesesteeweg 48C  
1932 St.-Stevens-Woluwe  
Belgium Fax (32) -2-725.97.80

# Table of Contents

Introduction.....	i-vii
Section 1: Safety .....	1-1
1.1 Important Safety Warnings .....	1-1
1.2 Personal Protective Equipment.....	1-2
1.3 Hazard Warnings .....	1-6
1.3.1 Toxic Gas Hazards.....	1-7
1.3.2 Corrosive Gas Hazards .....	1-8
1.3.3 Flammable and Pyrophoric Gas Hazards.....	1-9
1.3.4 Oxygen and Other Oxidizer Hazards .....	1-11
1.3.5 Inert Gas Hazards.....	1-13
1.3.6 Pressurized Gases.....	1-15
1.3.7 Cylinder Handling Hazards.....	1-15
1.3.8 Electrical Hazards .....	1-17
1.4 Typical Minimal Lockout or Tagout System Procedures .....	1-18
1.5 Safety Signs and Labels .....	1-22
1.6 Equipment Safety Features .....	1-28
1.7 Safety Literature for Handling and Use of Gas Cylinders .....	1-30
1.8 Safety Literature for Handling and Use of Instrument Nitrogen Supply .....	1-30
Section 2: System Description .....	2-1
2.1 Gas Cabinet.....	2-1
2.2 Rack Systems .....	2-3
2.3 Hazardous Gas Panel .....	2-4
2.4 Inert Gas Purge Panel.....	2-4
2.5 Interconnecting Piping .....	2-5
2.6 Auto Switchover System.....	2-6
2.7 Panel Schematic and Component Descriptions .....	2-7
2.8 Gasguard 450 Controller.....	2-13
2.8.1 Controller Components.....	2-13
2.9 Main Menu Options .....	2-19
Section 3: Operating Procedures.....	3-1
3.1 Emergency Shutdown Procedures.....	3-3
3.2 Operation of the GG450 Controller .....	3-4
3.2.1 Security Code.....	3-4
3.2.2 Keypad Operation .....	3-5
3.2.3 Entering the Password to Access the Main Menu Screen.....	3-7
3.3 Process and Purge Cylinder Procedures.....	3-10
3.3.1 Inert Purge Gas Cylinder Change Procedure .....	3-10
3.3.1.1 Empty Purge Gas Cylinder Removal .....	3-11
3.3.1.2 Full Purge Gas Cylinder Installation.....	3-12
3.3.1.3 CGA Connection Leak Check (Purge Cylinder).....	3-13
3.3.1.4 Putting Purge Gas Cylinder On-Stream .....	3-14
3.3.2 Process Gas Cylinder Procedures.....	3-15

3.3.2.1 Empty Process Gas Cylinder Removal (Prior to Removal).....	3-15
3.3.2.2 Empty Process Gas Cylinder Removal .....	3-19
3.3.2.3 Full Process Gas Cylinder Installation .....	3-21
3.3.2.4 Full Process Cylinder Purge (After Installation).....	3-23
3.3.2.5 Process Gas Flow .....	3-25
3.4 New System Startup Procedure.....	3-27
3.5 Manual Operation .....	3-31
3.5.1 How to Operate in Manual Mode .....	3-31
3.5.2 How to Open and Close Valves .....	3-33
3.5.3 General Principles of Manual Operation .....	3-34
3.6 Cabinet Configuration.....	3-35
Section 4: Troubleshooting .....	4-1
4.1 System Shut Down, No Lights on Controller .....	4-2
4.2 No or Low Purge Gas Pressure .....	4-2
4.3 No or Low Purge Gas Flow .....	4-3
4.4 No or Low Process Gas Pressure .....	4-4
4.5 No or Low Process Gas Flow .....	4-4
4.6 Typical Alarms.....	4-6
4.6.1 Excess Flow .....	4-6
4.6.2 Low Pneumatic Pressure .....	4-6
4.6.3 Low Process Cylinder Pressure or Very Low Process Cylinder Pressure .....	4-7
4.6.4 Low Vacuum at PT-1 .....	4-7
4.6.5 Low Purge Pressure at PT-1.....	4-7
4.6.6 High Pressure at Cylinder Connection (Diss, CGA, Keyed VCR, etc.) .....	4-8
4.6.7 Standby Leak Detected .....	4-8
4.6.8 CGA Leaking .....	4-8
4.6.9 Cylinder Leaking.....	4-9
4.6.10 High Process Delivery Pressure or Very High Process Delivery Pressure .....	4-9
4.6.11 Low Process Delivery or Very Low Process Delivery.....	4-9
4.6.12 Low Vacuum at PT-2.....	4-10
4.6.13 Low Purge Pressure at PT-2.....	4-10
4.6.14 Low Purge Cylinder Pressure or Very Low Purge Cylinder Pressure .....	4-10
4.6.15 Low Purge Delivery Pressure.....	4-11
4.6.16 High Purge Delivery Pressure .....	4-11
4.6.17 High Vent Pressure .....	4-11
4.6.18 Low Vacuum Generated PT-5 .....	4-12
4.6.19 High Purge Delivery PT-8 or Very High Purge Delivery PT-8.....	4-12
4.6.20 Low Cylinder Weight or Very Low Cylinder Weight.....	4-12
Section 5: Maintenance.....	5-1

5.1 Warranty.....5-1  
5.2 Routine Maintenance .....5-2  
5.3 Safety Interlock Maintenance.....5-6  
Section 6: System Specific Information.....6-1  
6.1 System Specifications .....6-3  
6.2 System Drawings .....6-5  
6.3 Recommended Spare Parts .....6-7  
6.4 Program Logic Chart.....6-9



# Introduction

---

This manual contains the information needed to safely operate and maintain the Air Products Gasguard® 450 Gas Cabinet System. Information on installation of the system is found in a separate manual, "Installation Manual for the Gasguard® 450 Gas Cabinet and Purge Panel Systems."

***Note: Air Products recommends that the customer develop a specific "Cylinder Change Work Instruction" for each gas cabinet, rack system or valve manifold box. The work instruction can be used as a step through check list procedure for trained operators.***

A standard industrial work instruction would include the following:

- System identification number, gas service, basic description of system, etc.
- Current operating data (pressure, cylinder weight, etc.), date, time, operator.
- Tools/supplies required for cylinder change (PPE required for the gas, leak testing equipment, torque wrench, gaskets, etc.)
- Step-through procedural check list to include specific customer PPE protocol, communications, customer leak test procedures, cylinder handling and storage procedures.

Consult your local Air Products technical representative if you need assistance in preparation of standard work instruction.

## Section 1: Safety

This section provides the safety information needed to safely operate the system. Material Safety Data sheets for the cylinder gases and the instrument nitrogen supply are included. ***The safety section is to be carefully read and understood before work is performed on the system.***

## Section 2: General Description

This section provides an overview of the system.

### **Section 3: Operating Procedures**

This section contains the procedures to prepare the system for operation and to operate it.

### **Section 4: Troubleshooting**

This section provides guidelines for solving operating system alarm problems. It is a general guide; reference to manufacturers' literature will be required in some cases.

### **Section 5: Maintenance**

This section provides a guide to routine maintenance operations.

### **Section 6: System Specific Information**

This section provides system specific information such as system specifications, drawings, recommended spare parts and the program logic chart.

The table below provides a quick reference as to the applicability of the manual's sections.

<b>Manual Section</b>	<b>Supervisory</b>	<b>Maintenance</b>	<b>Operations</b>
1. Safety	•	•	•
2: General Description	•	•	•
3: Operating Procedures	•	•	•
4: Troubleshooting	•	•	
5: Maintenance	•	•	
6: System Specific Information	•	•	•

The information and data contained herein are proprietary to Air Products and Chemicals, Inc. and are not to be copied, reproduced, duplicated or disclosed to others, in whole or in part, without prior written consent of Air Products and Chemicals, Inc. *This restriction shall not apply to any safety information contained in the manual. The safety information is intended for your use and we encourage you to copy it so that anyone using this equipment knows how to use it safely.*

# Section 1: Safety

---

## 1.1 Important Safety Warnings



*Failure to read, understand and follow the safety information found in this section can result in personal injury and death.*



*The operator must read and understand this safety section before operating the system. All operating and maintenance personnel must receive training and instruction by Air Products and Chemicals, Inc.*



*All cylinder storage areas must be continually monitored with an air quality monitor to prevent the danger of a hazardous atmosphere.*



*Before using the system, review your company's requirements for use of toxic, corrosive, flammable, pyrophoric, oxidizers and inert gas cylinders and electrically powered equipment. You must be thoroughly trained in your company's safety procedures and safety equipment (self-contained breathing apparatus, emergency shutdown systems, plant alarm locations, etc.)*



*Do not make any changes to the equipment independently. INJURY or DEATH may result from unauthorized modifications. All modifications to equipment MUST be approved in writing by an Air Products and Chemicals' Representative.*

## 1.2 Personal Protective Equipment



*Personal protective equipment, as defined in this section, must be worn when working with this system.*

Personal protective equipment is designed to protect personnel from inadvertent risk. The listed personal protective equipment must be worn regardless of operator or technician level of training and qualifications.

The minimum personal protective equipment required for operating and maintaining the Gasguard 450 system is dependent on the hazard category of the gas(es) being used. When a gas meets more than one hazard category, the PPE for the most hazardous category *must* be used. Refer to the hazard warnings in Section 1.3 (pages 1-6 to 1-17) for the hazards of the gas(es) being used.

In addition to the personal protective equipment, the following safety equipment is highly recommended and is required when APCI personnel operate this equipment. This equipment should be supplied by the customer prior to operating the Gasguard 450 system.

- Safety shower
- Emergency phones
- Eye wash
- Gas leak detection system for gases to be used (ex: MDA)

The gas leak detection system needs to warn personnel (through visible and audible alarms located near the gas cabinet) of a hazardous atmosphere. The gas sensor(s) need to be set up

to alarm at the lowest level of hazard of exposure. Upon activation of an alarm, follow the established shutdown procedures for your system.

- Adequate ventilation as described below:  
 The gas cabinet must be connected to an exhaust system that is capable of meeting the following criteria:
  1. A minimum of 200 feet per minute air velocity must be achieved across an opened access hatch to prevent operator exposure to hazardous gas. This velocity must be achieved as an average with 150 feet per minute minimum at any point of the opening.
  2. A minimum volume of air must flow through the cabinet to prevent a leak of hazardous gas from escaping the cabinet.
  3. In silane service, an air velocity of 200 feet per minute must be achieved across all unwelded fittings per UFC Article 80, Section 8004.1.18, 1994 edition.

The table below lists the exhaust requirement for GG450 Cabinets to meet the above requirements.

Standard				Static Pressure Requirement
Cabinet (Width)	Duct Size	Hatch Status	Exhaust Requirement	(inches water column)
1 cylinder (18")	6"	Open	205 CFM	0.09"
		Closed	175 CFM	0.42"
2 cylinder (24")	6"	Open	335 CFM	0.23"
		Closed	225 CFM	0.30"
3 cylinder (38")	8"	Open	370 CFM	0.09"
		Closed	356 CFM	0.30"

Silane (SiH <sub>4</sub> )				Static Pressure Requirement
Cabinet	Duct Size	Hatch Status	Exhaust Requirement	(inches water column)
1 cylinder	6"	Open	350 CFM	0.25"
		Closed	325 CFM	0.31"
2 cylinder	6"	Open	490 CFM	0.49"
		Closed	475 CFM	0.55"

The static pressure is measured in the exhaust duct 3 to 6 inches above the entrance to the round duct.

Baffles are used within the enclosure in silane service to direct the major portion of the exhaust flow across the panel piping.



*This exhaust system must be independent of any general plant exhaust system and must be designed for the types of gases being used. Ensure that only compatible gases are fed into the exhaust system. Be certain the exhaust system power and shut down interlocks comply with UFC and NFPA code requirements.*

- Scrubber with a pollution abatement system sized for maximum potential upset flow of hazardous gas.



*Hardhats are ALWAYS required in zones defined as "HARD HAT ZONES" (construction zones) whether or not they appear on the following lists.*

See the tables on the following pages for the classification of gases typically used in the Gasguard 450 system:

- Toxic Gases page 1-8
- Corrosive Gases page 1-9
- Pyrophoric Gases page 1-11
- Flammable Gases page 1-11
- Oxidizers page 1-13
- Inerts page 1-14



*If you are unsure what personal protective equipment list to follow for the gases being used, **DO NOT** continue. Failure to understand the hazards and use the proper personal protective equipment may cause **INJURY** or **DEATH**. Contact Air Products and Chemicals, Inc. for the gas category.*

Personal Protective Equipment for the gas categories follows:

### Personal Protective Equipment for Toxics

- Toxic gas leak detection (ex. MDA)
- Self contained positive pressure breathing apparatus
- Long sleeved Nomex suit
- Safety glasses with side shields
- Leather gloves
- Safety shoes

***NOTE: Most highly toxics (diborane, germane phosphine) are also flammable. Nomex suit is not required for non-flammable toxics (ex: nitrogen dioxide, boron trifluoride). All gases in Section 1.5 using the warning sign with POISON GAS on the left and FLAMMABLE GAS on the right REQUIRE the Nomex suit.***

### Personal Protective Equipment for Corrosives

- Corrosive gas leak detector (ex. MDA)
- Self contained positive pressure breathing apparatus
- Level C acid suit (jacket with bib overalls)
- Safety glasses with side shields
- Leather gloves
- Safety shoes

***NOTE: Either air quality monitoring or self contained breathing apparatus is required for corrosive gases. Air Products recommends the use of both. It is not required to use both, however at least one MUST be used at all times.***

### **Personal Protective Equipment for Pyrophorics**

- Pyrophoric gas leak detection (ex: MDA)
- Hard hat (fire hat with brim recommended)
- Long sleeved Nomex suit
- Face shield
- Safety glasses with side shields
- Leather gloves
- Safety shoes

### **Personal Protective Equipment for Flammables**

- Hard hat (fire hat with brim recommended)
- Long sleeved Nomex suit
- Face shield
- Safety glasses with side shields
- Leather gloves
- Safety shoes

### **Personal Protective Equipment for Inerts**

- Oxygen depletion monitor
- Safety glasses with side shields
- Leather gloves
- Safety shoes

## **1.3 Hazard Warnings**

The following hazard warnings detail system hazards. Follow the warnings to avoid personal *injury or death*. ***Do not work on the system before reading and understanding the following warnings.*** The hazard warnings include:

- Toxic Gases Hazards
- Corrosive Gases Hazards



- Flammable and Pyrophoric Gases Hazards
- Oxidizer Hazards
- Inert Gas Hazards
- Pressurized Gases
- Cylinder Handling Hazards
- Electrical Hazard.

Not all of the gas related hazards may apply to your system. For example, you may not be using any gases in the oxidizer class.



*Some gases have more than one hazard. For example, fluorine is toxic, corrosive and also an oxidizer.*

*The Pressurized Gases, Cylinder Handling Hazards and Electrical Hazard warnings apply to all Gasguard 450 systems.*



*The following is general information on typical gas hazards. It is not a substitute for training and Material Safety Data Sheets for all operators.*

### **1.3.1 Toxic Gas Hazards**



*Many of the gases used in the Gasguard 450 system can cause personal INJURY OR DEATH at very low concentrations.*

Many of these gases provide no physical warning signs (i.e. coughing, throat irritation, burning sensations, shortness of breath) to alert personnel of exposure to toxic levels.

Personal protective equipment required for use with toxic gases is detailed in Section 1.2 on page 1-5 of this manual.

A list of the toxic gases used in the Gasguard 450 system follows:

<b>Ammonia</b>	<b>Hydrogen fluoride</b>
<b>Arsine</b>	<b>Hydrogen sulfide</b>
<b>Boron trichloride</b>	<b>Methyl chloride</b>
<b>Boron trifluoride</b>	<b>Nitrogen dioxide</b>
<b>Carbon monoxide</b>	<b>Nitrogen trifluoride</b>
<b>Chlorine</b>	<b>Phosphine</b>
<b>Chlorine trifluoride</b>	<b>Phosphine mixtures</b>
<b>Diborane</b>	<b>Phosphorous pentafluoride</b>
<b>Diborane mixtures</b>	<b>Silane</b>
<b>Dichlorosilane</b>	<b>Silicon tetrachloride</b>
<b>Disilane</b>	<b>Silicon tetrafluoride</b>
<b>Fluorine</b>	<b>Sulfur tetrafluoride</b>
<b>Germane</b>	<b>Trichlorosilane</b>
<b>Hydrogen bromide</b>	<b>Tungsten hexafluoride</b>
<b>Hydrogen chloride</b>	

### 1.3.2 Corrosive Gas Hazards



*Corrosives such as chlorine, fluorine and ammonia can irritate and burn human tissue. They can cause personal INJURY and DEATH.*

Exposure to very small concentrations of corrosive gases can cause severe irritation of the eyes and respiratory system. At higher concentrations, they can cause *severe personal injury or death*.

Section 1.2 of this manual (page 1-5) lists the personal protective equipment required for use with corrosive gases.

A list of the corrosive gases used in the Gasguard 450 system follows:

<b>Ammonia</b>	<b>Hydrogen chloride</b>
<b>Boron trichloride</b>	<b>Hydrogen fluoride</b>
<b>Boron trifluoride</b>	<b>Hydrogen sulfide</b>
<b>Chlorine</b>	<b>Nitrogen dioxide</b>
<b>Chlorine trifluoride</b>	<b>Phosphorous pentafluoride</b>
<b>Dichlorosilane</b>	<b>Silicon tetrachloride</b>
<b>Fluorine</b>	<b>Silicon tetrafluoride</b>
<b>Hydrogen bromide</b>	<b>Tungsten hexafluoride</b>

### 1.3.3 Flammable and Pyrophoric Gas Hazards



*Flammable and pyrophoric gases can cause fire or explosions.*

#### **Pyrophoric gases will spontaneously ignite in air**

Pyrophoric gases do not need a source of ignition to burn. However, low concentrations may accumulate without pyrophoric ignition (i.e. silane can accumulate up to a concentration of 2 molar [number of moles of silane per fixed volume of air] percent before spontaneous ignition occurs). They will ignite in the presence of oxygen.

#### **Flammable mixtures can burn or explode**

Fire and explosion hazards can be controlled by preventing the formation of combustible fuel-oxidant mixtures and by eliminating sources of ignition such as sparks, open flames or other heat sources.

Flammable mixtures will burn when ignited and can explode when the concentration is above the lower explosive limit (LEL) and below the upper explosive limit (UEL) for that specific gas. Some flammable gases may accumulate as pockets in enclosed areas and subsequently explode if an ignition source is present. A flammable gas also presents an asphyxiating hazard in sufficient quantities to reduce oxygen concentration below 19.5%, however fire/explosion is typically the primary hazard.

### **Adequate ventilation is necessary**

Adequate ventilation helps reduce the possible formation of flammable mixtures in the event of a flammable gas leak. See table of page 1-3 which lists the exhaust requirements per enclosure size for all gases.

***NOTE: To avoid any possible hazardous reactions (i.e. fire, explosion, extremely corrosive or toxic mixtures) never vent incompatible gases out the same duct!***

### **Continually monitor the atmosphere**

Continually monitoring the atmosphere with a gas leak detector will alert the operator to a flammable or explosive atmosphere in the area.

***NOTE: The installation of a hydride detector is strongly recommended for silane and other pyrophoric gases to detect leaks or pockets of gas that may not spontaneously ignite!***

Air Products and Chemicals strongly recommends installation of a hydride detector to detect gas pocketing of pyrophoric gases.

### **Guidelines to avoid forming combustible mixtures**

Avoid forming combustible mixtures by adhering to the following:

- Do not admit flammable gases into an area that contains oxygen/air. Do not admit oxygen/air into an area that contains flammable gases.
- Maintain a small positive pressure in systems to prevent air from leaking into them when the equipment is shut down.
- Avoid venting of flammable gases through vents that do not contain an inert atmosphere.

Personal protective equipment required for use with pyrophoric and flammable gases is listed in Section 1.2 on page 1-6. ***Note that the personal protective equipment (PPE) for pyrophorics differs from the flammables. Be sure to use the proper PPE.***

A list of pyrophoric gases used in the Gasguard 450 system follows:

<b>Diborane</b>	<b>Phosphine</b>
<b>Disilane</b>	<b>Silane</b>

A list of flammable gases used in the Gasguard 450 system follows:

<b>Acetylene</b>	<b>Germane</b>
<b>Ammonia</b>	<b>Hydrogen</b>
<b>Arsine</b>	<b>Hydrogen mixtures</b>
<b>Carbon monoxide</b>	<b>Hydrogen sulfide</b>
<b>Diborane</b>	<b>Methane</b>
<b>Diborane mixtures</b>	<b>Methyl chloride</b>
<b>Dichlorosilane</b>	<b>Methyl fluoride</b>
<b>Disilane</b>	<b>Trichlorosilane</b>

#### 1.3.4 Oxygen and Other Oxidizer Hazards



*Systems using oxygen or other oxidizers (i.e. nitrogen dioxide, fluorine) have specific guidelines for specifying equipment, materials of construction and system cleanliness.*

#### **Follow safe practices when using oxygen or oxidizers (chlorine and fluorine)**

Oxygen concentrations in excess of 23% significantly increase the hazard exposure to personnel and equipment. Those materials which burn in air will burn more violently and explosively in oxygen/oxidizer enriched atmospheres. Guidelines for oxygen systems are found in CGA Pamphlet G-4.4. (Contact your gas supplier or the Compressed Gas Association to order CGA Pamphlets.) Only those personnel who have read and understand the hazards of oxygen or oxidizers and safe practices for these systems should be permitted to operate and maintain the system.

**Use only equipment specifically designed for oxygen or oxidizer service.**

Inappropriate materials of construction increase the danger of ignition of pipelines and controls. Pipe sizing is just as important to ensure all velocity restrictions for oxygen or oxidizers are met. Do not substitute components or equipment without considering these hazards. Refer to CGA Pamphlet G-4.4 for guidelines and specifications of oxygen systems. (Contact your gas supplier or the Compressed Gas Association to order CGA Pamphlets.)

**Maintain oxygen cleanliness at all times.**

All equipment and piping in contact with oxygen or oxidizers must be cleaned to specifications outlined in CGA Pamphlet G-4.1. (Contact your gas supplier or the Compressed Gas Association to order CGA Pamphlets.) Failure to clean components and piping increases the danger of ignition and fire. Note that the cleaning solvent must be thoroughly removed before the equipment can be placed into service. Maintain cleanliness during assembly, installation, and repair.

**No open flames, smoking, or sparks permitted near oxygen equipment.**

Since many materials will burn in oxygen/oxidizer enriched atmospheres, the best method in preventing fires is to eliminate sources of ignition. Where this control equipment is being used or where concentrations of oxygen are greater than 23%, avoid open flames, sparks, or sources of heat. Never weld on a pressurized line flowing oxygen or an oxidizer. Make sure signs are posted warning personnel that oxygen or oxidizers are in use.

**Do not substitute oxygen for compressed air.**

Substituting oxygen for compressed air is dangerous. *Explosions can occur when oxygen is substituted for air.* Chances are the instrument air equipment is not compatible or cleaned for oxygen service. Oxygen used to clean off equipment or clothing could come in contact with a source of ignition (spark, flame, or other) and ignite. In some cases, the elevated oxygen levels could linger even after the source has been shut off. Never tie into an oxygen system for personnel breathing purposes.

A list of oxidizers used in the Gasguard 450 system follows:

Chlorine	Nitrogen trifluoride
Chlorine trifluoride	Nitrous oxide
Fluorine	Oxygen

### 1.3.5 Inert Gas Hazards



*High concentrations of nitrogen, helium, or other inert gases can cause an oxygen deficient atmosphere in a confined area which can cause DEATH. All personnel must read and understand the Material Safety Data Sheet(s) (MSDS) for the specific gas(es) being used.*

Oxygen concentrations of 19.5% or less can greatly increase the hazard of asphyxiation to personnel. Before working in an area where nitrogen, helium or other inert gases could be present, check the area with an oxygen monitor to be sure the oxygen concentration is between 19.5% and 23%. While working in the area, the oxygen concentration needs to be monitored with a continuous oxygen monitor. Always provide adequate ventilation in the work area to decrease the risk of an oxygen deficient atmosphere. **Read APCI Safetygram 17 "Dangers of Oxygen Deficient Atmospheres" included in the safety literature in Section 1.8 of this manual.**

Any time an oxygen deficient atmosphere is suspected, the proper personal protective equipment must be used. See the information on personal protective equipment in Section 1.2 on page 1-6 for details.

Personnel in an oxygen deficient atmosphere will not realize they are being asphyxiated. Breathing of pure inert gases will cause immediate unconsciousness. Symptoms of asphyxia include:

- Rapid breathing
- Nausea
- Vomiting
- Inability to move
- Convulsive movements

- Collapse
- Abnormal pulse
- Rapid fatigue
- Faulty judgment
- Insensitivity to pain
- Abnormal emotions

Remove any personnel in an oxygen deficient atmosphere to fresh air. *Get medical attention immediately. Use cardiopulmonary resuscitation if the victim is not breathing. Positive pressure breathing apparatus must be worn by any rescuers entering a suspected oxygen deficient atmosphere.*

Nitrogen gas may accumulate in low or confined areas. All requirements of OSHA 1910.146 (Confined Space Guidelines) must be met when inert gases in confined spaces. Self contained breathing apparatus is required (cartridge or filter type gas masks cannot be used). See the information on personal protective equipment in this section for details.

When entering a confined area or area which may contain high inert gas concentrations, a "**Buddy System**" must be used. One person should remain outside the suspect area, but within view of the other person. This method ensures that the other person can respond in the event of an emergency.

Personal protective equipment required for use with inerts is listed in Section 1.2 on page 1-6.

A list of inert gases used in the Gasguard 450 system follows:

<b>Argon</b>	<b>Halocarbon 115</b>
<b>Carbon Dioxide</b>	<b>Halocarbon 116</b>
<b>Halocarbon 11</b>	<b>Helium</b>
<b>Halocarbon 12</b>	<b>Krypton</b>
<b>Halocarbon 13</b>	<b>Neon</b>
<b>Halocarbon 14</b>	<b>Nitrogen</b>
<b>Halocarbon 22</b>	<b>Perfluoropropane</b>
<b>Halocarbon 23</b>	<b>Sulfur Hexafluoride</b>
<b>Halocarbon 113</b>	<b>Xenon</b>





*Any gas, in addition to those listed above, used in the Gasguard 450 gas cabinet could potentially displace the oxygen in the air and cause asphyxiation.*

### 1.3.6 Pressurized Gases



*Pressurized gas lines can injure personnel and damage equipment. Never tighten or loosen a fitting when it is under pressure.*

The process and purge gas cylinders can contain pressures up to 2640 psig. A leak from a loose mechanical fitting, component or a ruptured/failed component can expose the operator to a high pressure gas stream or projectile. *Read the cylinder handling warnings in Section 1.3.7 and the safety literature on cylinder handling in Section 1.7.*

The house nitrogen supply lines can contain pressures of 100+ psig. Exercise care when working around these lines. Insure that pressure has been vented before breaking any connection. Tag out and lock out the line before doing any work. *Follow Typical Minimal Lockout or Tagout System Procedures described by Occupational Safety and Health Admin., Labor Para. 1910.147 found in Section 1.4 of this manual.*

### 1.3.7 Cylinder Handling Hazards



*High pressure gas cylinders can be extremely hazardous when not handled properly.*

Proper training, maintenance, leak testing and mechanical connection procedures can prevent operators from being exposed to high pressure gas streams. *Use the cylinder change out procedures in Section 3.3.2, "Process Cylinder Procedures," of this manual.*

- Do not use a wrench or other device to close diaphragm type cylinder valves. This could cause diaphragm rupture and valve failure which

*could result in personal injury or death.* Contact your gas supplier for the maximum torque (ft./lbs.) allowed on diaphragm type cylinder valves. Certain gases are supplied with cylinder valves without handwheels. Use **only** the tool specified by your gas supplier to open and close diaphragm type cylinder valves to avoid over torquing these valves.

- If a cylinder valve protection cap is extremely difficult to remove, do not apply excessive force or pry the cap loose. Attach a label to the cylinder identifying the problem and notify the personnel responsible for returning cylinders about the defective cylinder. Obtain another cylinder. Do not attempt to open a frozen cap as this would damage the cylinder valve and *could result in personal injury or death.*
- Do not rotate the cylinder using the cylinder valve handle. This may open the cylinder valve and cause a high pressure gas leak.
- **NEVER** replace the gas specified for use in the cabinet with another type of gas cylinder. Incompatible gases could cause fires, explosions or extremely corrosive or toxic mixtures which can *cause personal injury or death.* If another type of gas is required for use in the gas cabinet, contact Air Products and Chemicals, Inc. immediately.
- A valve outlet sealing cap **must** be supplied on all toxic, corrosive and pyrophoric gases. Consult your gas supplier if there is no sealing cap on any of the above types of gas cylinders.
- Cylinder valves are available with removable flow restrictor orifices in the valve outlet for use with gas cylinders. This flow restrictor orifice significantly limits the rate of release of gas from the valve outlet during transportation, storage and use, due to a valve or system failure. Verify that your gases are supplied in cylinders with valves that have the appropriate flow restrictor orifice. Note that there are different size flow restrictor orifices available. Verify that the correct size is being used for your specific situation. A quality control program should be established to assure that your supplier has installed the correct flow restrictor orifice in the valve outlet after the filling operation has been completed.

### 1.3.8 Electrical Hazards



*Electric shock can cause personnel injury or death.*

The control circuits for the system use 115/220 VAC, 50/60 Hz. Do not attempt to work on the system without first turning the power off and tagging out and locking out the electrical supply disconnect switch per plant lock out procedures. *Follow the Typical Minimal Lockout or Tagout System Procedures described by Occupational Safety and Health Admin., Labor Para. 1910.147 found in Section 1.4 of this manual.*

## **1.4 Typical Minimal Lockout or Tagout System Procedures**

*NOTE: The following OSHA document is included to help you develop a lockout/tagout procedure for the Gasguard 450 System. A written procedure is required for any work performed under lockout/tagout. It must be reviewed, approved and understood by all participants who are trained to perform the work.*

(Occupational Safety and Health Admin., Labor Para. 1910.147)

### **General**

Lockout is the preferred method of isolating machines or equipment from energy sources. To assist employers in developing a procedure which meets the requirements of the standard, the following simple procedure is provided for use in both lockout and tagout programs. This procedure may be used when there are limited number of types of machines or equipment or there is a single power source. For a more complex system, a more comprehensive procedure will need to be developed, documented and utilized.

### **Lockout (or Tagout) Procedure for (Name of Company)**

#### **Purpose**

This procedure establishes the minimum requirements for the lockout or tagout of energy isolating devices. It shall be used to ensure that the machine or equipment is isolated from all potentially dangerous energy, and locked out or tagged out before employees perform any servicing or maintenance activities where the unexpected energization, start-up or release of stored energy could cause injury (Type(s) and Magnitude(s) of Energy Hazards).

#### **Responsibility**

Appropriate employees shall be instructed in the safety significance of the lockout (or tagout) procedure (Name(s)/Job title(s) of employees authorized to lockout or tagout). Each new or transferred affected employee and other employees whose work operations are or may be in the area shall be instructed in the purpose and use

of the lockout or tagout procedure (Name(s)/Job title(s) of affected employees and how to notify).

### **Preparation for Lockout or Tagout**

Make a survey to locate and identify all isolating devices to be certain which switch(s), valve(s) or other energy isolating devices apply to the equipment to be locked or tagged out. More than one energy source (electrical, mechanical, or others) may be involved. (Type(s) of energy isolating means).

### **Sequence of Lockout or Tagout System Procedure**

1. Notify all affected employees that a lockout or tagout system is going to be utilized and the reason therefore. The authorized employee shall know the type and magnitude of energy that the machine or equipment utilizes and shall understand the hazards thereof.
2. If the machine or equipment is operating, shut it down by the normal stopping procedure (depress stop button, open toggle switch, etc.).
3. Operate the switch, valve, or other energy isolating device(s) so that the equipment is isolated from its energy source(s). Stored energy (such as that in springs, elevated machine members, rotating flywheels, hydraulic systems, and air, gas, steam or water pressure, etc.) must be dissipated or restrained by methods such as repositioning, blocking, bleeding down, etc. (Type(s) of stored energy methods to dissipate or restrain).
4. Lockout and/or tagout the energy isolating devices with assigned individual lock(s) or tag(s) (Method(s) selected, i.e., locks, tags, additional safety measures, etc.)
5. After ensuring that no personnel are exposed, and as a check on having disconnected the energy sources, operate the push button or other normal operating controls to make certain the equipment will not operate (Type(s) of equipment checked to ensure disconnections).

### **CAUTION**

**RETURN OPERATING CONTROL(S) TO NEUTRAL OR OFF POSITION AFTER THE TEST.**

6. The equipment is now locked or tagged out.

## **Restoring Machines or Equipment to Normal Production Operations**

1. After the servicing and/or maintenance is complete and equipment is ready for normal production operations, check the area around the machines or equipment to ensure that no one is exposed.
2. After all tools have been removed from the machine or equipment, guards have been reinstalled and employees are in the clear, remove all lockout or tagout devices. Operate the energy isolating devices to restore energy to the machine or equipment.

## **Procedure Involving More Than One Person**

In the preceding steps, if more than one individual is required to lockout or tagout equipment, each shall place his/her own personal lockout device on the energy isolating devices(s). When an energy isolating device cannot accept multiple locks or tags, a multiple lockout or tagout device (HASP) may be used. If lockout is used, a single lock may be used to lockout the machine or equipment with the key being placed in a lockout box or cabinet which allows the use of multiple locks to secure it. Each employee will then use his/her own lock to secure the box or cabinet. As each person no longer needs to maintain his/her lockout protection, that person will remove his/her lock from the box or cabinet (Name(s)/Job title(s) of employees authorized for group lockout or tagout).

## **Basic Rules for Using Lockout or Tagout System Procedure**

All equipment shall be locked or tagged out to protect against accidental or inadvertent operating when such operation could cause injury to personnel. Do not attempt to operate any switch, valve or other energy isolating device where it is locked or tagged.

(See following page.)

Entry No.	Description
1.	Name of Company
2.	Type(s) and Magnitude(s) of energy and hazards
3.	Name(s)/Job title(s) of employees authorized to lockout or tagout
4.	Name(s)/Job title(s) of affected employees and how to notify
5.	Type(s) and Location of energy isolating means
6.	Type(s) of stored energy
7.	Method(s) selected, i.e. locks, tags, additional safety measure, etc.
8.	Type(s) of equipment checked to ensure disconnections
9.	Name(s)/Job title(s) of employees authorized for group lockout or tagout

1910.147 29 CFR Ch.XVII (7-1-90)

## 1.5 Safety Signs and Labels

The following sign is located on the door of the Gasguard 450 cabinet.

**DANGER: GASES USED IN THIS CABINET  
MAY BE HAZARDOUS TO HEALTH  
SAFETY AND THE ENVIRONMENT**

THIS CABINET AND GAS HANDLING EQUIPMENT SHOULD ONLY BE USED BY TRAINED, AUTHORIZED OPERATORS. Before using, read and understand the user manual for this equipment and the Air Products Material Safety Data Sheet(s) for the gas(es) in use. Copies can be obtained from your supervisor.

WHEN USING THIS EQUIPMENT:

1. MAKE SURE EXHAUST SYSTEM IS ON AND WORKING.
2. MAKE SURE GAS IN CYLINDER IS THE SAME AS IDENTIFIED ON THE ABOVE GAS LABEL. IF NOT, OTHER HAZARDS MAY BE PRESENT.
3. VISUALLY INSPECT CABINET AND GAS HANDLING EQUIPMENT THROUGH THE WINDOW FOR SIGNS OF LEAKAGE, CORROSION, OR MECHANICAL FAILURE. IF PRESENT, CONTACT SUPERVISOR.
4. PURGE THE EQUIPMENT WITH INERT GAS BEFORE CHANGING CYLINDER OR MAKING REPAIRS.
5. CHECK CYLINDER VALVE CONNECTION FOR LEAKS AFTER CHANGING CYLINDER.
6. CHECK GAS HANDLING EQUIPMENT FOR LEAKS AFTER MAINTENANCE OR IF THE CABINET HAS BEEN PHYSICALLY DISTURBED.
7. CLOSE CYLINDER VALVE WHEN NOT IN USE AND WHEN EMPTY.

IN AN EMERGENCY, CONTACT YOUR SUPERVISOR, IF THE CYLINDER IS LEAKING, OR IF FURTHER ASSISTANCE IS REQUIRED, CALL THE AIR PRODUCTS EMERGENCY RESPONSE PHONE NUMBERS.

800-523-9374 (Continental USA, Canada, Puerto Rico)  
610-481-7711 (All other locations)

AIR PRODUCTS AND CHEMICALS, INC.  
SEMICONDUCTOR EQUIPMENT MANUFACTURING CENTER  
1919 VULTEE STREET  
ALLENTOWN, PA 18103





The following sign is located on the Gasguard 450 controller. This label is required if the area the cabinet is installed is Class I, Division II rated.

ENCLOSURE SHALL NOT BE OPENED UNLESS AREA IS KNOWN TO BE NON-HAZARDOUS OR UNLESS THE POWER HAS BEEN REMOVED FROM ALL DEVICES WITHIN THE ENCLOSURE.

POWER SHALL NOT BE RESTORED AFTER ENCLOSURE HAS BEEN OPENED UNTIL ENCLOSURE HAS BEEN PURGED FOR 10 MIN.

The following eleven labels are specific to the gases being used. They are located on the door of the Gasguard 450 cabinet. They are identical to the labels on the process gas cylinder in the GG450 cabinet to provide verification that the correct process gas is being installed and used.



*The signs shown below are DOT classifications. They are not to be used to classify gas hazards. Refer to the appropriate MSDS sheets in Section 1.7.*

The following label would be used with the gases listed below it:



THIS EQUIPMENT IS DESIGNED FOR USE WITH:



**Boron trifluoride  
Chlorine  
Phosphorous pentafluoride**

**Tungsten hexafluoride  
Sulfur tetrafluoride**

The following label would be used with the gases listed below it:

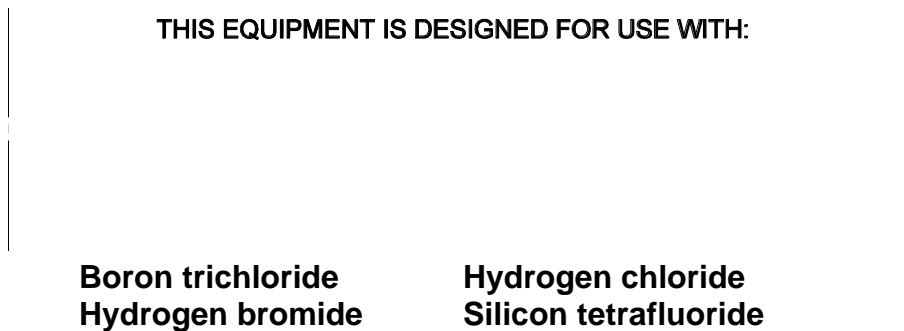

The following label would be used with the gases listed below it:

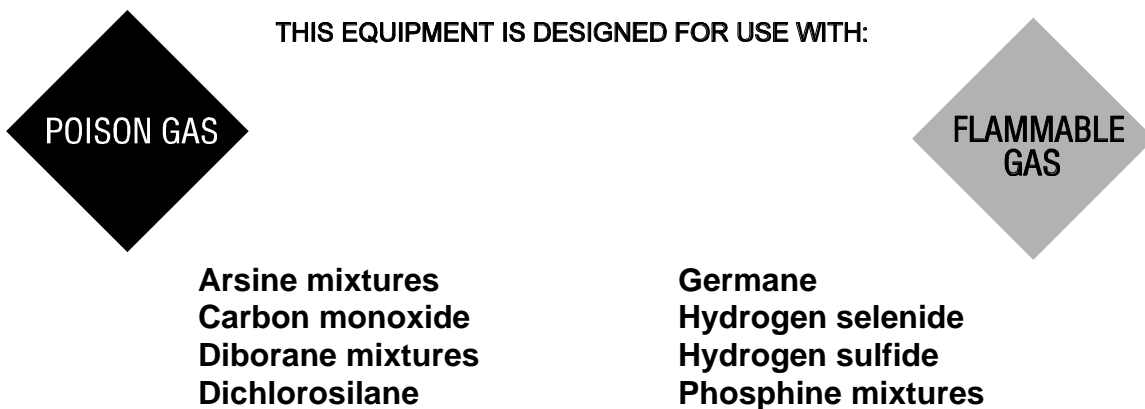

The following label would be used with the gases listed below it:



The following label would be used with the gases listed below it:



THIS EQUIPMENT IS DESIGNED FOR USE WITH:



**Acetylene  
Disilane  
Hydrogen  
Hydrogen mixtures**

**Methane  
Methyl chloride  
Silane  
Silane mixtures**

The following label would be used with the gases listed below it:



THIS EQUIPMENT IS DESIGNED FOR USE WITH:

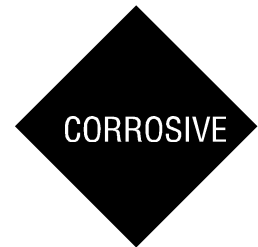

**Silicon tetrachloride**

The following label would be used with the gases listed below it:



THIS EQUIPMENT IS DESIGNED FOR USE WITH:



**Oxygen**

The following label would be used with the gases listed below it.



**THIS EQUIPMENT IS DESIGNED FOR USE WITH:**



**Carbon tetrachloride**

The following label would be used with the gases listed below it.



**THIS EQUIPMENT IS DESIGNED FOR USE WITH:**

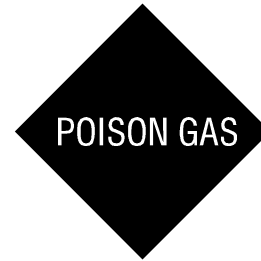

**Hydrogen fluoride**

The following label would be used with the gases listed below it:



**THIS EQUIPMENT IS DESIGNED FOR USE WITH:**



**Ammonia  
Argon  
Carbon dioxide  
Halocarbon 11  
Halocarbon 12  
Halocarbon 13  
Halocarbon 14  
Halocarbon 22  
Halocarbon 23  
Halocarbon 113**

**Halocarbon 115  
Halocarbon 116  
Helium  
Krypton  
Neon  
Nitrogen  
Nitrous oxide  
Perfluoropropane  
Sulfur hexafluoride  
Xenon**

The following label would be used with the gases listed below it:



**THIS EQUIPMENT IS DESIGNED FOR USE WITH:**



**Oxygen mixtures  
Nitrogen trifluoride**

**Nitrogen trifluoride mixtures**

## **1.6 Equipment Safety Features**

Dependent on the design of your specific system, the following safety features may be incorporated into the Gasguard 450 system:

- Warning labels and gas identification labels are placed on the outside door of each cabinet (see Section 1.5).
- The gas cabinet has a self-closing cabinet door with locking mechanism.
- A sprinkler head is installed in the cabinet, unless water is a hazard with the specific gas used in the cabinet.
- Cabinet doors have self-closing 1/4" thick wire reinforced safety glass windows.
- Fault and Shutdown alarms notify the operator through the alarm horn, light and alarm label on the controller of a problem with the system. In addition, the Shutdown alarms close all pneumatic valves and abort the controller program.
- Excess flow sensors are installed, when required, to shut off the flow of gas in the event of downstream equipment failure.
- An exhaust monitor verifies adequate ventilation for the cabinet.
- The system may utilize a tied diaphragm regulator. This type of regulator is designed to close tightly if the pressure builds above the setpoint because the diaphragm is mechanically connected to the valve poppet. Be aware that the regulator may leak if the regulator seat is damaged, corroded or soiled.
- A flow restricting orifice may be installed in the cylinder valve or in the CGA nipple. This flow restricting orifice significantly reduces the flow of gas in the event of a failure in the downstream equipment.
- An ultraviolet infrared (UVIR) detector is required for pyrophoric gas systems.
- A temperature switch is a required option for flammable gases.
- Pressure relief valves may be incorporated into the design to prevent overpressurization of the process line and downstream equipment and to protect the inert purge system.

- Manual operation access is denied during the presence of a digital shutdown alarm.
- An "EMERGENCY STOP" pushbutton is located on the controller panel.
- A password security system prevents unauthorized personnel to operate or modify the Gasguard 450 controller menu.

## **1.7 Safety Literature for Handling and Use of Gas Cylinders**

The following safety literature, located directly after this page, *must be read and understood.*

APCI Safetygram 10	Handling, Storage and Use of Compressed Gas Cylinders
APCI Safetygram 11	Emergency Action in Handling Leaking Compressed Gas Cylinders
APCI Safetygram 14	Don't Turn a Cylinder into a Rocket
APCI Safetygram 15	Cylinder Safety Devices
APCI Safetygram 23	Cylinder Valves
Material Safety Data Sheets for all gases used in system	

## **1.8 Safety Literature for Handling and Use of Instrument Nitrogen Supply**

The safety literature listed below follows the safety literature for Section 1.7 and *must be read and understood.*

APCI Safetygram 2	Gaseous Nitrogen
APCI Safetygram 17	Dangers of Oxygen Deficient Atmospheres
Nitrogen Material Safety Data Sheet	



## **Section 2: System Description**

---

The Gasguard 450 Automatic Hazardous Gas System consists of a gas cabinet, one or two process gas panels, an inert purge gas panel and a single or dual GG450 controller. For inert gases and silane, the process and purge panels and controllers may be mounted on an open rack.

Some Gasguard systems can be used to back up another system and can be switched to automatically, if needed. The minimum hardware requirements to operate in auto switchover mode are:

- Dual Gasguard 450 controller, or two single GG450 controllers configured as such, and
- Two process gas panels sharing process outlet piping

Gasguard Systems are designed and built for the safe storage and handling of high purity toxic, flammable, pyrophoric, corrosive, oxidizing, and reactive cylinder gases. The systems have been designed in accordance with the applicable requirements of the Uniform Fire Code (UFC). Copies of the UFC may be obtained from Western Fire Chiefs Association, 5360 South Workman Mill Road, Whittier, California 90601.

### **2.1 Gas Cabinet**

The function of the Gasguard Cabinet is to ensure a safe environment for personnel during cylinder changes or in the unlikely event of a leak of hazardous gas. The cabinet must be connected to a properly designed exhaust system that is continuously operated and monitored in order to provide a safe environment.

The cabinet provides the secondary containment for any leak from the hazardous gas cylinder, cylinder connection and pigtail, and the process panel. The exhaust system continuously removes any leaking hazardous gas from the cabinet to a safe disposal system.

The Gasguard 450 Cabinet is constructed of 12 gage steel with fully welded seams and protected with corrosion resistant polyurethane paint. Cabinet sizes are available to hold from one to three cylinders. One or more exhaust stacks are provided for connection to the customer's exhaust system.

The Cabinet has 12 gage steel doors with windows constructed of 1/4" thick wire reinforced safety glass. A temperature activated (165° F) sprinkler head is provided, in accordance with Article 51 of the UFC. Formed brackets are mounted inside of the cabinet to securely hold each cylinder. There is a weight scale option for use with cylinders containing liquefied gases.

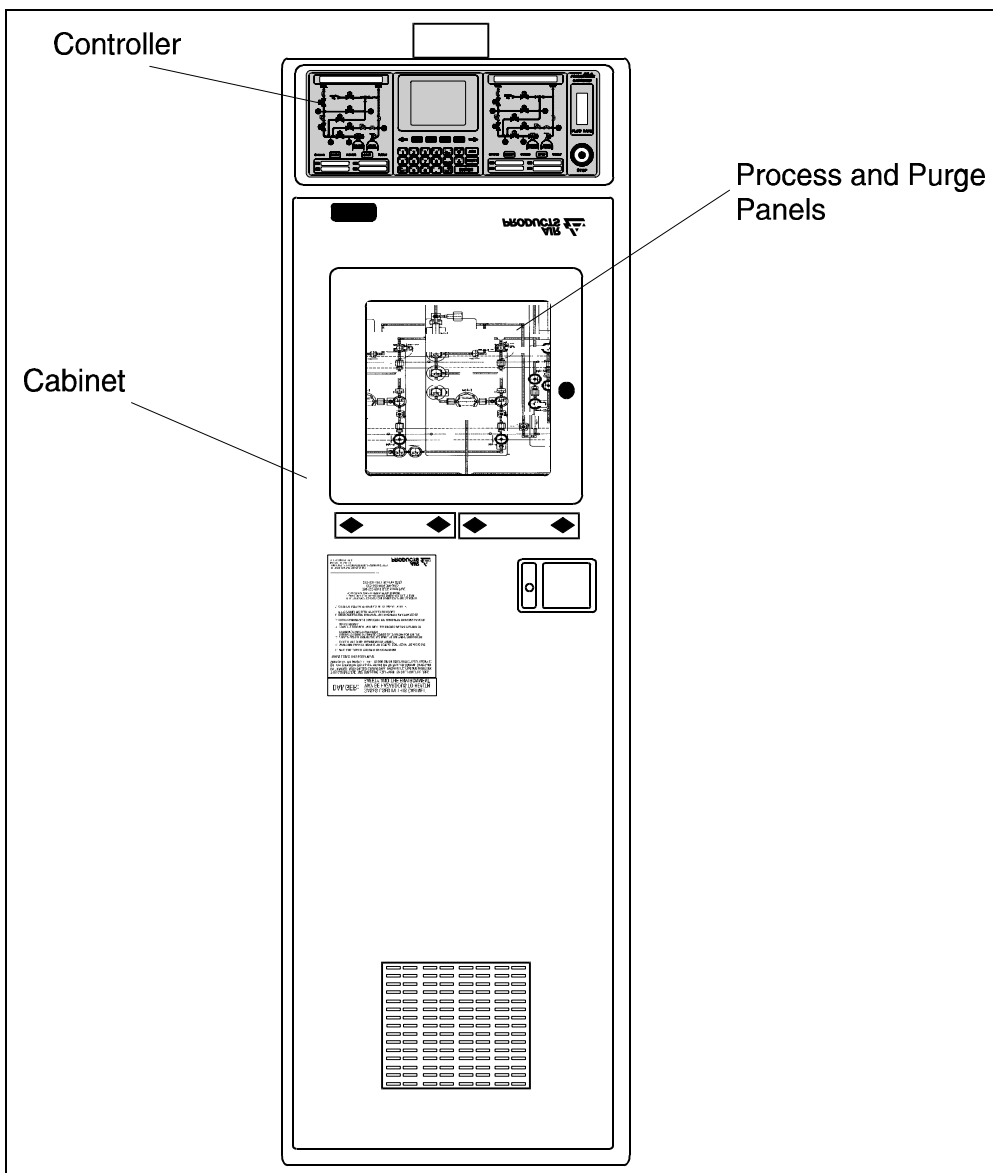

**Figure 2-1: Gasguard 450 cabinet**

## 2.2 Rack Systems

A Rack System is a free-standing open platform for inert and silane gas handling systems. Its design will accommodate process and purge panels, gas cylinder and a controller. No exhaust hook-up is required.

The use of a rack system for silane distribution is the preferred alternative to gas cabinets that minimizes the potential for silane pocketing and subsequent explosion.

NFPA 318 and UFC 80-1 lend insight into open rack design. In addition any local building codes need to be followed when considering the use of a rack system.

A typical rack system is shown in Figure 2-2.

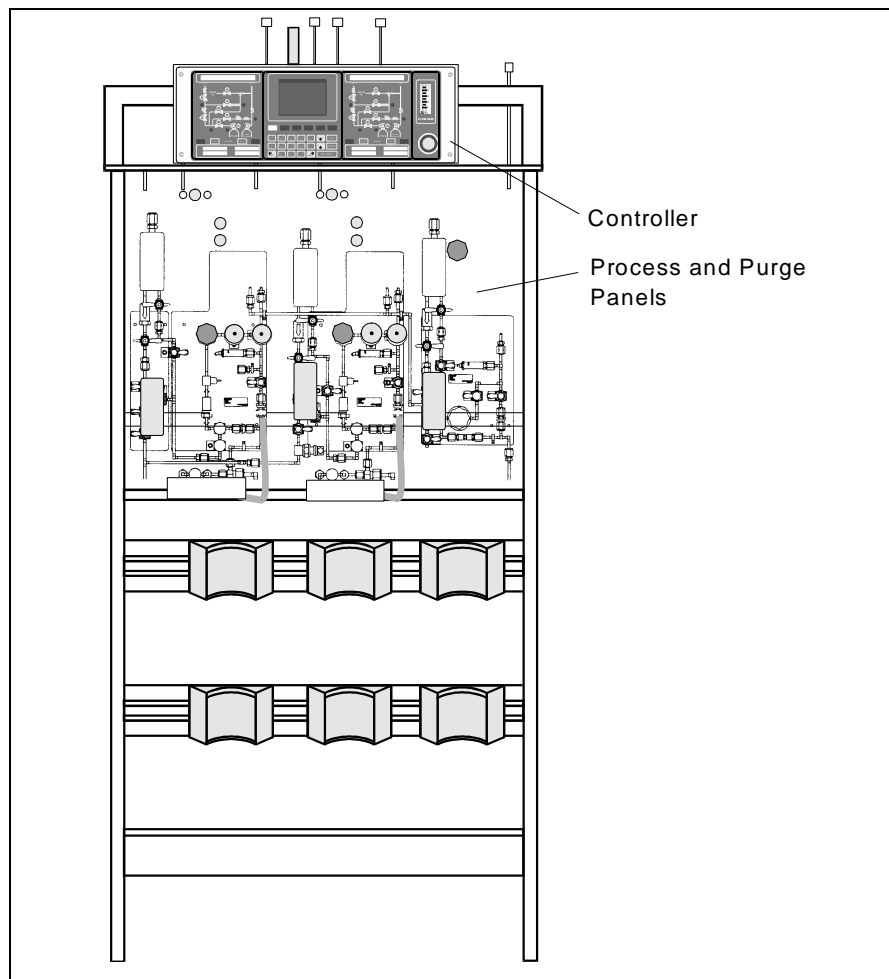

Figure 2-2: Typical Rack System

## **2.3 Hazardous Gas Panel**

The Hazardous Gas Panel is used to perform the following functions:

- Regulate cylinder pressure to the process tool working pressure.
- Remove hazardous process gas from the panel prior to changing the process cylinder.
- Provide immediate shut-off in a hazardous situation using fail-safe pneumatic valves (optional) if required for the specific gas.
- Maintain process tubing purity during process cylinder change.

The panel may include pneumatic valves, manual valves, pressure transducers, pressure gauges, pressure regulators, check valves, relief valves and safety/purity components such as filters and purifiers.

Pneumatic valves are used to shut off process gas flow, to control purge gas flow into the process panel, to vent process gas and purge gas from the panel and to feed inert gas to the vacuum venturi system. Check valves are used as backup to prevent process gas flow into the purge gas panel and back into a house nitrogen venturi supply, and to prevent contamination of the panel from the exhaust system. Safety relief valves (if installed) are used to prevent overpressure of the process line and downstream equipment and to protect the inert gas purge system. Pressure transducers and switches, and excess flow sensors are used in conjunction with a controller to provide immediate shutoff if a hazardous situation is detected.

All components and tubing are type 316L stainless steel. Hastelloy C-22 trim is used in corrosive gas regulators. All components handling the process gas or purge gas are welded into the system or use Cajon VCR fittings or equivalent. The panels are connected to the gas cylinder by a stainless steel pigtail and a CGA or DISS fitting that is defined specifically for each type of gas. A flow restricting orifice may be installed in the cylinder valve or pigtail nipple to minimize hazardous gas flow from the cylinder in the event of a downstream catastrophic failure.

## **2.4 Inert Gas Purge Panel**

This panel controls the pressure and flow of purge gas to the hazardous gas panel during the purge sequence and cylinder change-out procedure. The panel is constructed using similar materials and techniques as the hazardous gas panel.

## 2.5 Interconnecting Piping

Exterior tubing terminates above the top of the cabinet and is prepared for butt welding to customer lines by orbital tube welding equipment. The purge panel is connected to the process panel thereby avoiding any field piping work within the cabinet. Vent lines and safety relief valves are joined together and terminated outside the cabinet for connection to the customer's pollution abatement system.

See Figure 2-3 below for a typical gas cabinet panel layout.

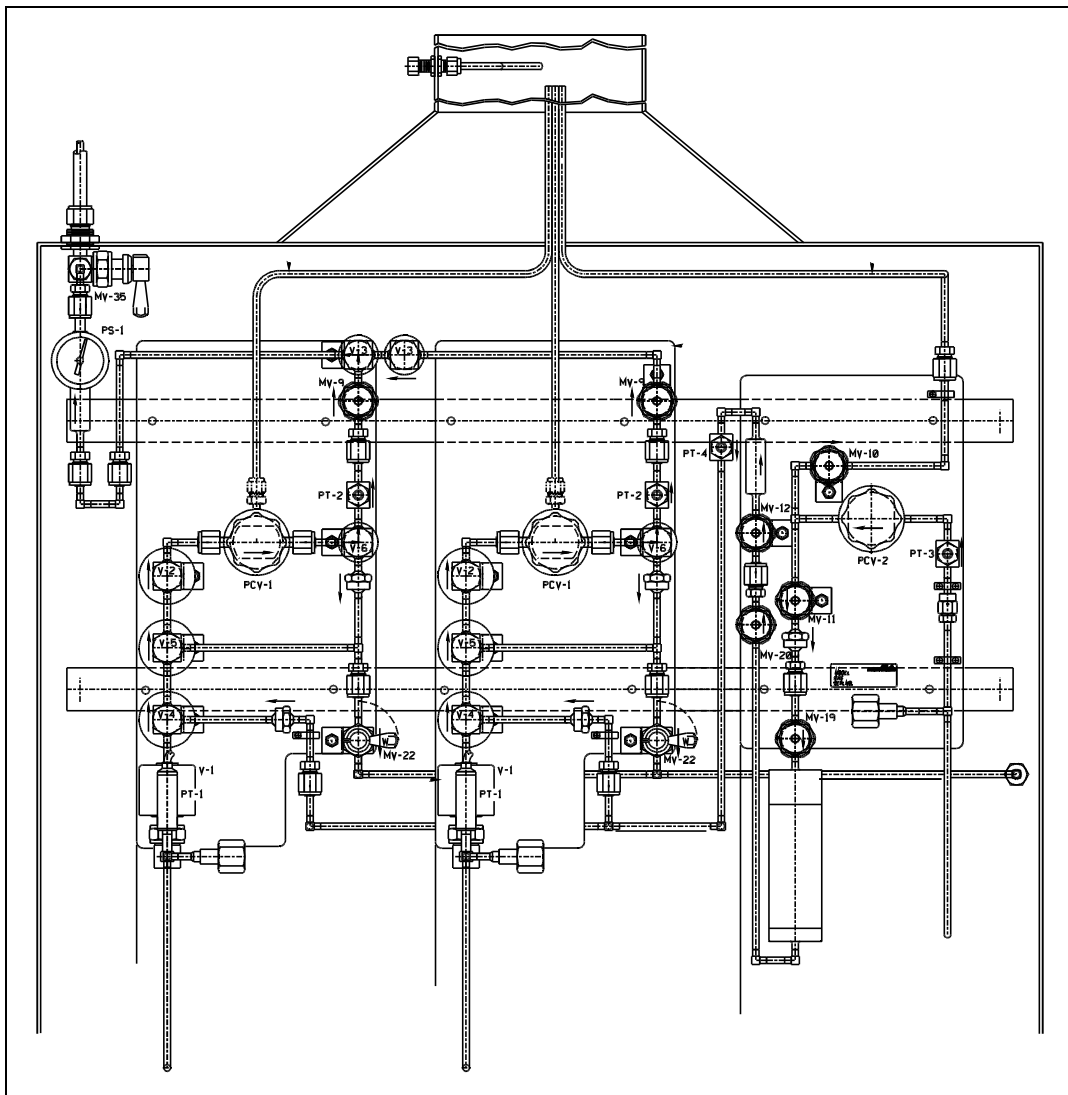

**Figure 2-3:** Typical Gasguard 450 Back Panel

## 2.6 Auto Switchover System

Minimum hardware requirements for the automatic switchover system are a dual Gasguard 450 controller, or two single Gasguard 450 controllers configured as such, and two process gas panels sharing the process out piping. Process gas switchover between right and left cylinders is initiated by either a low process gas cylinder pressure or weight (on liquid cylinders). This switchover setpoint is set and entered by the customer. Switchover can be induced prematurely by the operator simply by stopping gas flow on the cylinder which is currently flowing. The adjacent cylinder will begin flowing gas immediately.

For automatic switchover to occur, both cylinders must be placed into a "PROCESS GAS FLOW" mode. Whichever cylinder is started first will begin flow, the other cylinder will wait in a "standby" state until the cylinder flowing gas is stopped by either a "LOW" alarm or the operator. If a global related shutdown alarm arises, both cylinders will return to the "IDLE" mode and all pneumatic valves will close.

After an automatic switchover has occurred, the low process cylinder can be purged for a cylinder change while the other cylinder is flowing gas. This cycle is called "PRE-PURGE". When the automated pre-purge cycles are completed, the "CHANGE CYLINDER" mode must be selected. The cylinder can physically be removed and replaced during this time. During a cylinder change-out procedure, sufficient Personal Protective Equipment (PPE) must be worn assuming hazardous process gas is still present in the pigtail line. See Section 1.2 of this manual for details on PPE.

With a new cylinder in place, the next step would be "POST-PURGE". Any air which may have entered the pigtail and valve connection during changeout is removed during these purging cycles. When post-purge is complete, the cylinder can be put into the "PROCESS GAS FLOW" mode again, which will now place it into standby until the other cylinder is stopped.

## 2.7 Panel Schematic and Component Descriptions

Figure 2-4 is a flow schematic of a typical Gasguard 450 Process/Process/Purge Cabinet Auto Crossover System.

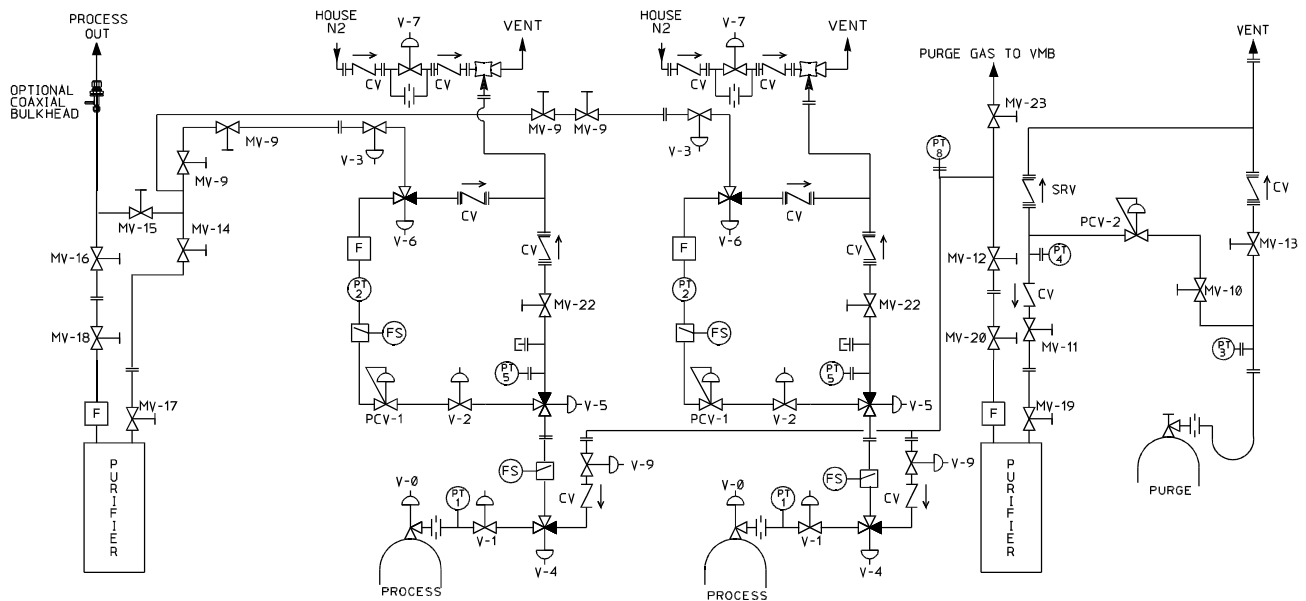

**Figure 2-4:** Process/Process/Purge Cabinet Auto Crossover System Schematic

The function of each component is described in the table.

**V-1      Emergency Shutoff Valve (On Pigtail)**

This pneumatic valve located on the pigtail close to the gas cylinder shuts off the process gas flow when a shutdown alarm occurs or the E-Stop button is pressed.

**V-2      High-Pressure Process Isolation Valve**

This pneumatic valve isolates the pressure regulator and downstream components from the high pressure process gas.

**V-3      Low-Pressure Process Isolation Valve**

This pneumatic valve isolates the gas cabinet piping from the facility process piping.

**V-4 Purge Gas Inlet Valve (On Pigtail)**

This pneumatic valve controls the on/off flow of purge gas to the high pressure side of the process panel and pigtail.

**V-5 High-Pressure Vent Valve**

This pneumatic valve permits flow from the high pressure portion of the panel to vent.

**V-6 Low-Pressure Vent Valve**

This pneumatic valve permits flow from the low pressure portion of the panel to vent.

**V-7 Vacuum Venturi Supply Valve**

This pneumatic valve uses house nitrogen flow to create a vacuum to evacuate the process piping during purge sequences.

**V-8 (V-0) Process Cylinder Valve**

This valve located on the process cylinder is opened to allow process gas to flow from the cylinder to the pigtail. If the valve is pneumatically operated, it will automatically close on shutdown alarms. Solenoid valve, V-8, in the controller is used to supply the pneumatic cylinder valve (if present).

**V-9 Trickle Purge Valve (On Pigtail) (Optional)**

This pneumatic valve is used in series with V-4 to provide a trickle purge from an open pigtail connection during cylinder change. The valve has a small orifice which allows a continuous flow of purge gas when it is closed and V-4 is open.

**PT-1 Process Cylinder Pressure Transducer**

This transducer measures the process gas pressure at the cylinder outlet. It is also used to check pressures during purge cycles.



**PT-2 Process Delivery Pressure Transducer**

This transducer measures the process gas pressure on the outlet side of the pressure regulator.

**PT-3 Purge Cylinder Pressure Transducer**

This transducer measures the pressure of the purge gas at the cylinder outlet.

**PT-4 Purge Delivery Pressure Transducer**

This transducer measures the pressure of the purge gas on the outlet side of the purge regulator.

**PT-5 Vent Line Pressure Transducer**

This transducer measures the vacuum pressure in the vent piping created by the vacuum venturi.

**PT-8 Purge Line Pressure Transducer (Optional)**

This transducer measures the pressure in the purge header downstream of the purge purifier. It is used when one purge system is used to supply more than one process panel or VMB. It is only used on process gas with a cylinder pressure over 250 PSIG.

**MV-9 Process Line Isolation Valve**

This manual valve isolates the process line and downstream equipment from the low pressure process supply. It is used to isolate the cabinet from the process line. In crossover systems, two MV-9 valves may be used in series to provide dual isolation during maintenance.

**MV-10 High Pressure Purge Gas Isolation Valve (Optional)**

This manual valve isolates the purge regulator from the high pressure purge supply.

**MV-11 Low Pressure Purge Gas Isolation Valve (Optional)**

This manual valve isolates the purge gas pressure regulator from the downstream components.

**MV-12 Purge Gas Purifier Isolation Valve (Optional)**

This manual valve isolates the purge purifier from the process panel.

**MV-13 Purge Gas Vent Valve**

This manual valve is used to remove air from the purge cylinder connection after purge cylinder installation.

**MV-14 Process Purifier Isolation Valve (Optional)**

This manual valve isolates the process purifier inlet from process gas.

**MV-15 Process Purifier Bypass Valve (Optional)**

This manual valve allows process, purge or test gases to bypass the process purifier when open. It is used in conjunction with MV-14 and MV-16. It should be closed during normal process gas flow.

**MV-16 Process Purifier Isolation Valve (Optional)**

This manual valve isolates the purifier outlet from process gas.

**MV-17 Process Purifier Inlet Valve (Optional)**

This manual valve isolates the purifier when removed from the system.

**MV-18 Process Purifier Outlet Valve (Optional)**

This manual valve isolates the purifier when removed from the system.

**MV-19 Purge Purifier Inlet Valve (Optional)**

This manual valve isolates the purifier when removed from the system.

**MV-20 Purge Purifier Outlet Valve (Optional)**

This manual valve isolates the purifier when removed from the system.

**MV-21 Purge Gas Isolation Valve (Optional)**

This manual valve is only used when the nitrogen purge panel is external to the cabinet.

**MV-22 Vent Isolation Valve**

This manual valve isolates the downstream vent system from the high pressure vent side of the process panel. It is used when there is a helium leak test port in the high pressure vent downstream of V-5. The valve should be left open except when performing a helium leak test.

**MV-23 Purge Gas Outlet Isolation Valve to Valve Manifold Box**

This manual valve isolates the gas cabinet purge panel from the downstream purge gas line exiting the cabinet to supply other cabinets or valve manifold boxes.

**MV-31 Leak Test Isolation (Optional)**

This manual valve isolates a leak test port (typically a VCR connection) from the process panel.

**MV-36 Fill Port Isolation (Optional)**

This manual valve isolates the fill port (typically a VCR connection) from the coaxial process line.

**PCV-1 Process Gas Pressure Regulator**

This regulator controls the pressure of the process gas to the process equipment.

**PCV-2 Purge Gas Pressure Regulator**

This regulator controls the purge gas pressure.

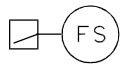

### **Flow Switch (Optional)**

This device senses an excess flow of process gas caused by downstream system failure (tubing or component leak, valve or regulator failure, etc.) and sends a switch signal to the controller to shutdown the system.



### **Filter**

This device removes particles from the gas stream.



### **Check Valve**

This safety device is used to prevent backflow of gas into another section of the system.



### **Safety Relief Valve**

This device is used to relieve an over-pressure condition caused by failure of another device, primarily pressure regulators.



### **Vacuum Venturi**

This device is used to pull a vacuum on the process panel during purge cycles. It uses a flow of nitrogen past an orifice to create a vacuum as low as 26" Hg.

## 2.8 Gasguard 450 Controller

The Gasguard 450 controller is a microprocessor-based unit housed in a custom designed metal enclosure. It continuously monitors system inputs and automatically performs purging operations by sequencing valve actuation. Adequate purging is ensured by checking pressure and vacuum at each step within the purge cycles. The controller also has the capability of shutting down the system if an unsafe condition arises.

The controller utilizes a color-coded graphics panel that allows the operator to easily understand the operation and to quickly identify operating problems. The process gas flow path is red, inert gas flow is green, and vented gas flow is yellow.

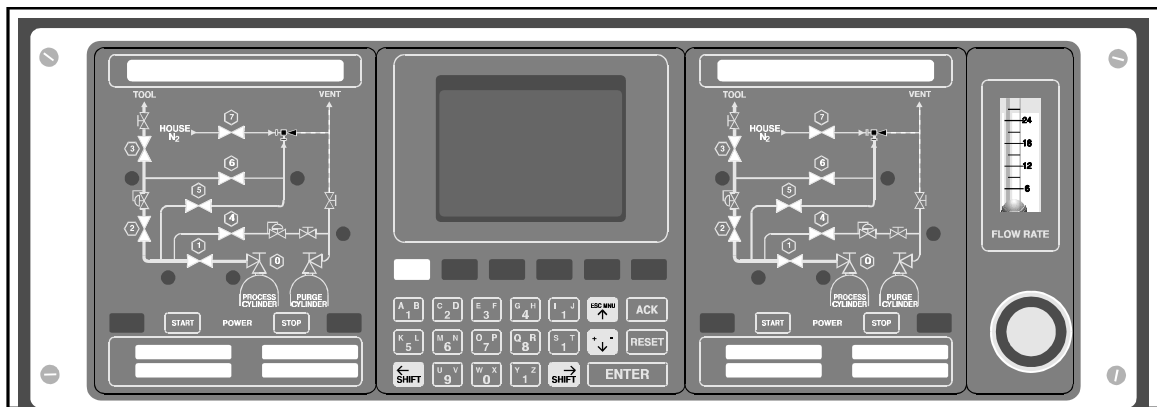



Figure 2-5: Gasguard 450 Controller

### 2.8.1 Controller Components

#### The LCD Screen

The LCD screen is located in the center of the controller face. Its 16 line by 20 character display presents prompts, menu selections, process and purge gas pressures, and alarms. The display has a backlight feature for easy viewing, which is activated whenever a key is pressed. To extend the life of the LCD, the backlighting is automatically turned off after 2 minutes without a key press.

The LCD shown below is for a dual controller. The left arrow at the top left corner of the screen indicates that the left side of a dual controller can be accessed or controlled from the keypad. The information on the bottom half of the screen pertains to the right controller. If the right arrow would be highlighted at the right side in the middle of the screen, the keypad would allow access or control to the

right side. To switch sides on a dual controller, use the  and  keys on the keypad.

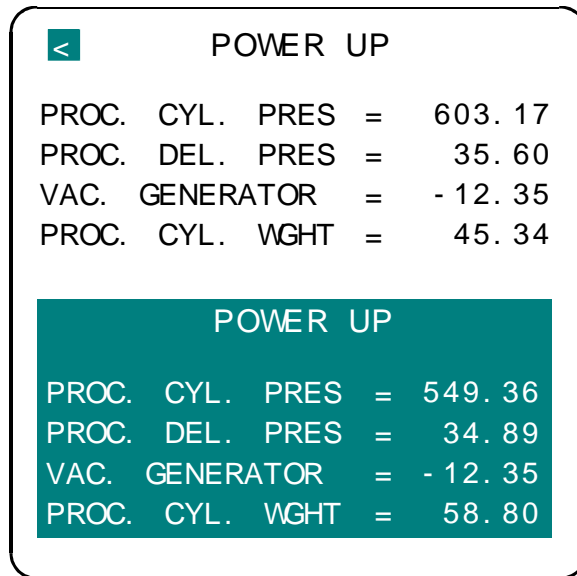





Figure 2-6: Gasguard 450 Power Up Screen

Press the Press   keys on the keypad to display "all" the analog readings on the LCD screen.

Any alarms will appear on this screen. First data will appear, then shutdown alarms will appear on the top line, with fault alarms underneath. If more than one is present, they will scroll on the screen. In the event of an incoming alarm, press the  key, not the  key on the keypad.

## The Keypad

The keypad is located in the center of the controller, below the LCD screen. The twenty membrane key-switches provide a means of selecting controller functions and entering various alarm setpoints. When a key is pressed the system responds with a short beep. This beep is an acknowledgment to the key press and occurs regardless of the effect of the key press on the system. Refer to Section 3.2 Operation of the Cabinet Controller of this manual for information on how to use the keypad.

Figure 2-7, below, shows the keypad.



Figure 2-7: Gasguard Controller Keypad

## Graphic Display

The graphic display, located on the left side of the cabinet controller, provides, through a lighted display, visual indication of pneumatic valve positions. Open valves are shown in red. Closed valves are shown in green. The valve condition colors conform to ISA standards.

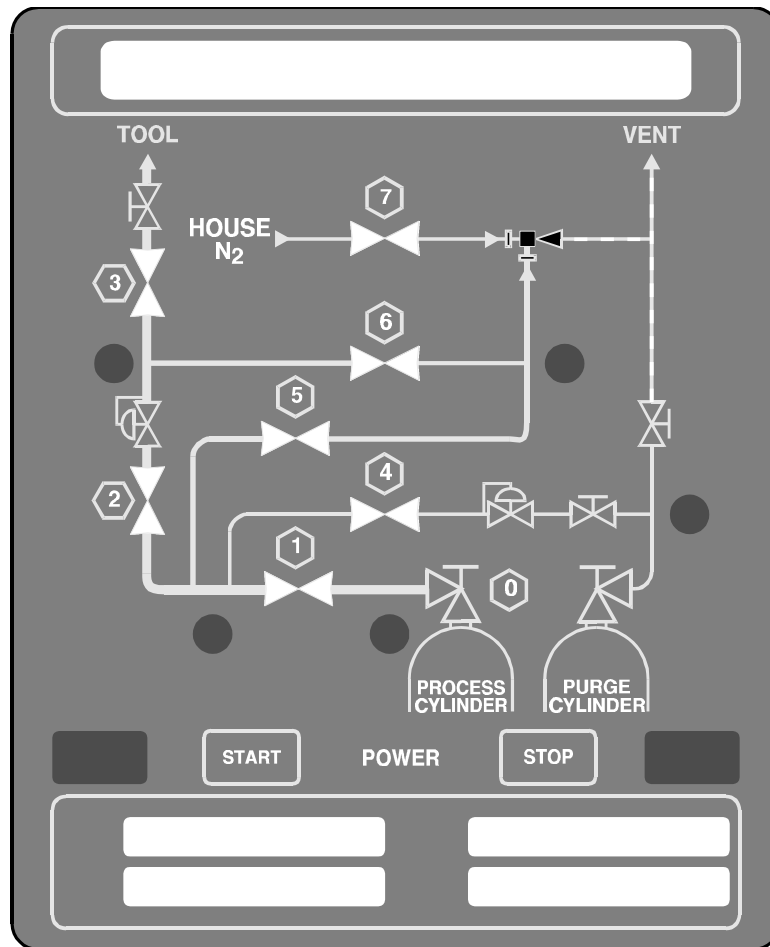

**Figure 2-8:** Gasguard 450 Controller Graphic

Additionally, LEDs and membrane switches, which control the cabinet functions, are located below the graphic display. The table on the next page describes these switches and their functions.



<b>Switch/LED</b>	<b>Function</b>
<b>SHTDWN</b>	This LED flashes red on power up and for an un-acknowledged shutdown alarm. Once acknowledged, the LED stops flashing but remains red until it is reset.
<b>START</b>	When pressed, this switch will start the sequence which is highlighted on the LCD screen.
<b>POWER</b>	This LED is lighted in green under normal operating conditions. It is red if a communications board has failed in a networked system.
<b>STOP</b>	When pressed, this switch will stop the sequence which is highlighted on the LCD screen.
<b>FAULT</b>	This LED flashes yellow on power-up and for a fault alarm. Once acknowledged, the LED stops flashing but remains yellow until it is reset.

## **Flowmeter**

The flowmeter, located on the right side of the cabinet controller, indicates the flow of purge gas to the interior of the controller enclosure. Its use is required only in Class I, Division II or greater designated areas. The flow rate should be approximately 6 SCFH of nitrogen.

## **Emergency Stop**

The red, mushroom head push-pull emergency stop button, located on the right side of the cabinet controller, shuts off power to the pilot solenoids, closing all of the pneumatic valves. Power is maintained to the controller, but it cannot open the valves until the button is pulled out to its normal position.

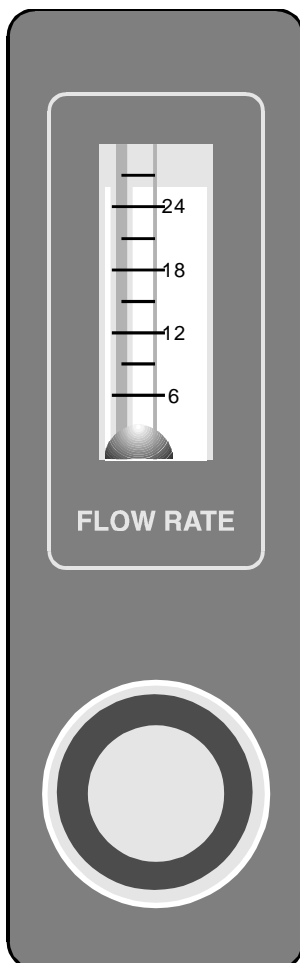

**Figure 2-9:** Emergency Stop Pushbutton and Flowmeter

## 2.9 Main Menu Options



*The following descriptions of system sequences are not intended as a guide to operation. Use specific operating procedures, provided in Section 3, to operate the system*

The main menu provides access to the controllers' sequences. It is password-protected. Section 3.2 explains how to enter a password. Some options are only available after completing another sequence. For example, a cylinder change must be preceded by pre purge.

The following options are available from the main menu:

### Return to Display

This option is highlighted when the Main Menu is displayed.

If you press **ENTER**, the default screen for the active process will display.

If you do not select an option within 2 minutes, the controller will drop out of the Main Menu automatically, and display the active process screen.

### Process Gas Flow

This option starts and stops the process gas flow.

The start sequence tests the process panel for adequate process pressures.

If problems are found, process gas flow is not started and an alarm is displayed. Details of these alarms are located in Section 6 (System Specific Information) of this manual.

If no problems are found, the process gas flow is started. Flow continues until a process stop, or until an alarm condition causes a shutdown.

### Pre Purge

This option starts the pre purge sequence prior to cylinder change.

It tests for a gross leak at the cylinder valve. The primary purpose of this test is to provide operator safety and protect purity of the system.

The pre purge sequence tests for adequate vacuum, then initiates a series of purges of the process piping to remove all process gas to a safe level before changing the process gas cylinder.

The number of purge cycles depends on the type of process gas. Minimum values are built into the sequence. Cycles may be increased (See Cabinet Configuration in Section 3.6 of this manual), but not reduced below the minimum.

### Change Cylinder

This option is used when changing the process cylinder. It must be preceded by a pre purge sequence.

This sequence tests for high pressure, which is an indication of a process cylinder valve leak, and then establishes a trickle purge flow through the pigtail for cylinder removal and replacement.

If a safe condition is detected, you are prompted to remove the spent cylinder and replace it.



*Cylinder change procedures are located in Section 3.3. Do not attempt to change a cylinder without following appropriate procedures.*

### Post Purge

This option starts the post cylinder change purge sequence.

The post cylinder change purge sequence purges the process panel after a process cylinder change. It tests for gross leaks at the pigtail cylinder connection.

As with the pre purge, the number of purge cycles is determined by the process gas type. Cycles may be increased (See Cabinet Configuration in Section 3.6 of this manual), but not reduced below the minimum.

## Rough Line Evac (Optional)

This menu option is used to purge the major quantity of hazardous gas remaining in the process line to the tool. The purge evacuation capabilities of the Gasguard process panel are used to remove this gas into the cabinet vent system.



*This sequence alone does not remove the process gas from the process line to a low enough concentration to permit operator maintenance or other activities on the process line or downstream components. The customer must develop purge and evacuation procedures for the process line and downstream components to assure safe low concentrations of hazardous gas to permit maintenance on this equipment. This normally is accomplished by flowing purge gas through the process line and tool.*

This sequence can be initiated after completion of any other menu option. The Aux Purge operation includes the Pre Purge sequence at the start of the cycle.

## Lamp Test

This option energizes all of the controller's LED lamps and audible outputs. This verifies that all LED's and internal outputs are functioning.



## Section 3: Operating Procedures

---

This section will describe the operating procedures. The following procedures are included.

- 3.1 Emergency Shutdown Procedures
- 3.2 Operation of the Cabinet Controller
- 3.3 Purge and Process Cylinder Procedures
- 3.4 New System Start-Up Procedure
- 3.5 Manual Operation
- 3.6 Cabinet Configuration



*Be sure you have read and understood the safety information located in Section 1 of this manual before operating the system. You should also be familiar with the location and function of all components. This information is located in Section 2 "System Description".*



*Prior to operating the system, the proper installation procedures need to be completed. This information is found in the "Installation Manual for the Gasguard 450 Gas Cabinet and Purge Panel Systems."*



*The gases being used in this equipment may be extremely hazardous. It is the customer's responsibility to assure that only experienced, trained operators, thoroughly familiar with this manual, the equipment and operating procedures, the hazards and the safety procedures are permitted to operate this system.*



*Air Products and Chemicals requires the handling of any toxic gas cylinders be performed by two trained operators utilizing self contained breathing apparatus.*



### 3.1 Emergency Shutdown Procedures

In the event of an emergency, press the "EMERGENCY STOP" pushbutton on the controller panel and *evacuate the area*. See Figure 3.1 below. This will close all valves, any process or purge program is aborted, the alarm horn will sound and the shutdown alarm light will flash.

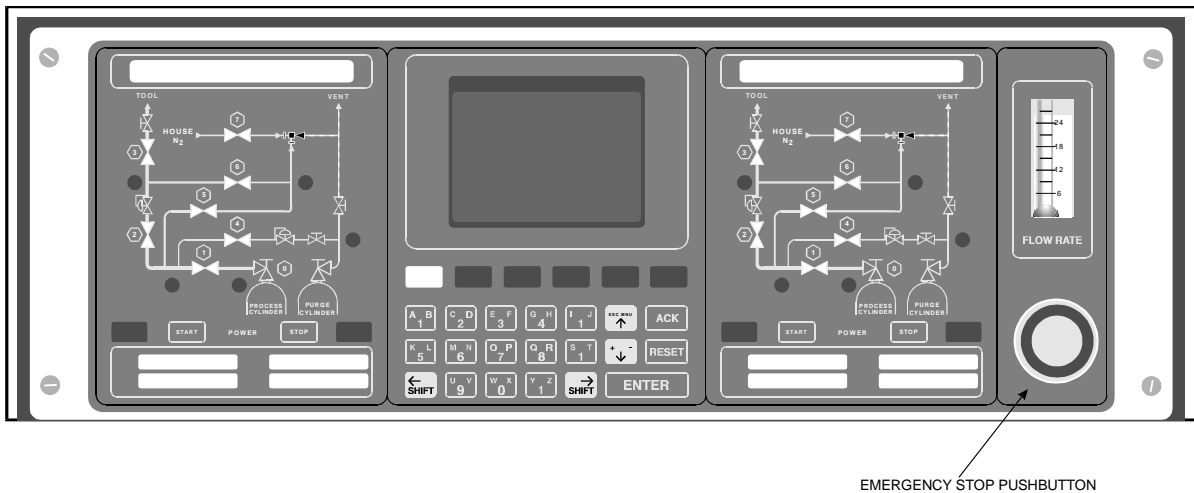

Figure 3.1: Emergency Stop Pushbutton Location



*Pressing the "Emergency Stop" button does not disconnect power to the controller. The 120 VAC/240 VAC power is still active within the controller. Do not perform maintenance on the controller without disconnecting or switching off power externally and following the required Lockout or Tagout procedures.*



*If it is necessary to reenter the area while a hazardous atmosphere is suspected, the proper Personal Protective Equipment (PPE) must be worn. See Section 1.2 of this manual for the proper PPE.*

## **3.2 Operation of the GG450 Controller**

### **3.2.1 Security Code**

Four levels of password security are used in the controller to prevent unauthorized operation by untrained personnel.

Each trained operator is assigned a 4-8 character first level password. A first level password allows the operator to start and stop process flow, and initiate purge and change cylinder procedures. Access to Manual Mode and the Configuration Menu is not permitted.

Trained supervisory personnel are assigned a second or third level security password.

The second security level allows access to Manual Mode and the Configuration Menu. It permits the user to change certain operating parameters, to view other menu selections and restricts access to other files.

The third security level allows access to additional files in the Configuration Menu for changing parameters or viewing only.

The fourth security level is restricted to Air Products personnel only.

### 3.2.2 Keypad Operation

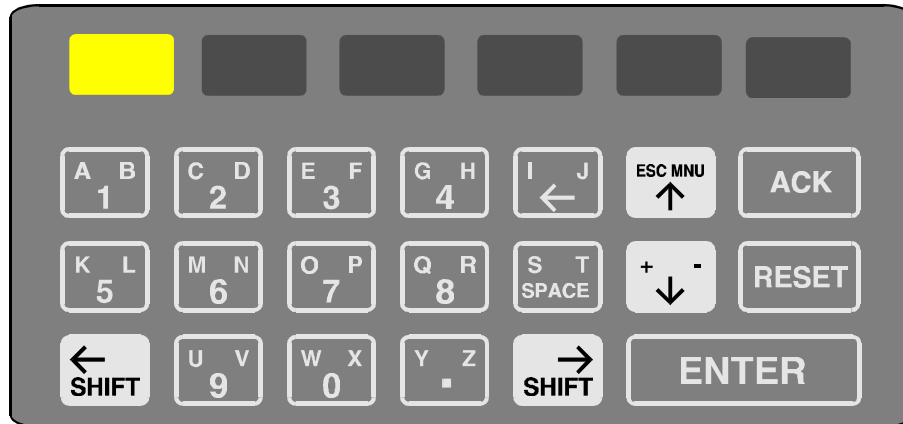



Fifteen of the keys on the keypad have a combination of three letters, numbers or symbols on them as shown below.





Each key has three possible entries (inputs) to the controller.

Pressing the key by itself will enter the bottom center symbol into the controller, i.e. 1, 2, ↑, ↓ respectively.

The  and  are used to enable (activate) the keypad to input the upper left or upper right symbols. The shift keys only enable the keypad for the next key press, therefore the proper shift key must be pressed each time an upper left or upper right symbol is to be input to the controller.

The value on the upper left of the key (i.e. A, C, Esc, +) is entered by pressing the left shift key , and then pressing the desired key.



The value on the upper right of the key (i.e. B, D, Mnu, -) is entered by pressing the right shift key , and then pressing the desired key.

Note that you will have to use the right shift key  each time you want to obtain a menu .



The function of the other keys on the keypad are described below:



**Acknowledge**  **Key** - Press this key to silence the horn when any new shutdown or fault alarm occurs. Flashing red or yellow LEDs will change to steady on.

**Reset**  **Key** - Pressing this key will clear an acknowledged alarm if the alarm condition has been corrected. If it is not corrected, the controller will re-alarm.

**Up Arrow**  **and Down Arrow**  **Keys** - Use these keys to highlight a menu choice, a file from the configuration menu, or select a parameter within a configuration file (i.e. user setpoints).

For dual controllers, use these keys to switch between the left and right controllers. The left or right side must be selected before entering passwords to select menus. A lit LED below the LCD screen indicates whether the left or right side is being displayed on the screen.

**Menu**   **Keys** - Press the two keys in sequence, and enter the password to display the Main Menu.

**Escape**   **Keys** - Pressing these two keys in sequence returns the operator to the previous screen when in a multi-level screen sequence.

**Enter**  **Key** - Press this key to enter passwords, to select highlighted Main Menu options or configuration files, or to enter new operating parameter setpoints, etc. into system configuration files.



**Start**  **Key** - This key is located below the graphic display. Press this key to start a menu operation highlighted on the Main Menu, i.e. Process Gas Flow

**Stop**  **Key** - This key is located below the graphic display. Press this key to stop an operation, highlighted on the Main Menu.

### 3.2.3 Entering a Password to Access the Main Menu Screen



This is the screen that is displayed whenever the controller is powered up, not receiving input from the keyboard or is not running a programmed procedure. The controller will switch to this screen after 2 minutes of inactivity (except when it is waiting for input during a programmed sequence).

All operations on the system must be started from a Main Menu screen on the controller. A valid password must be entered to obtain a menu on the LCD screen.

Press the  and then the  key to request the main menu. The controller will request your password on the LCD screen.

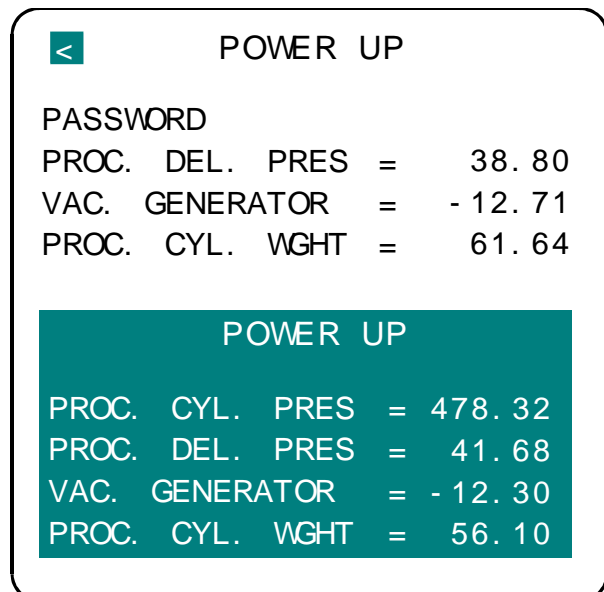
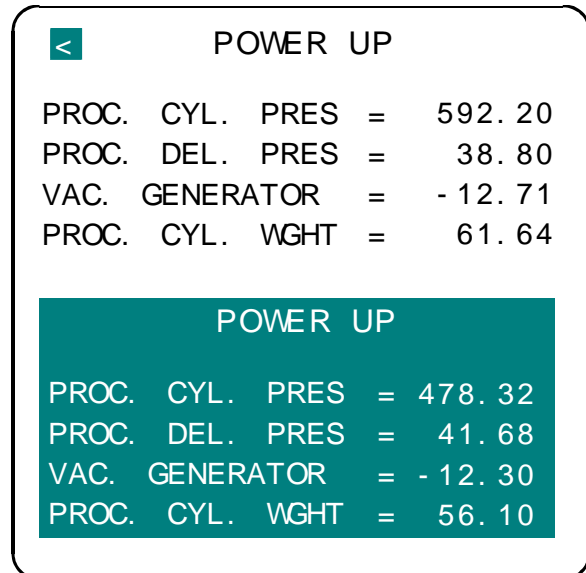





The screen will change to:





Enter the password using the  keys as required and the  number/letter keys. An X will appear as each number is entered to prevent your password from being displayed to others. Press .

Example:

To enter the password "A2J7":

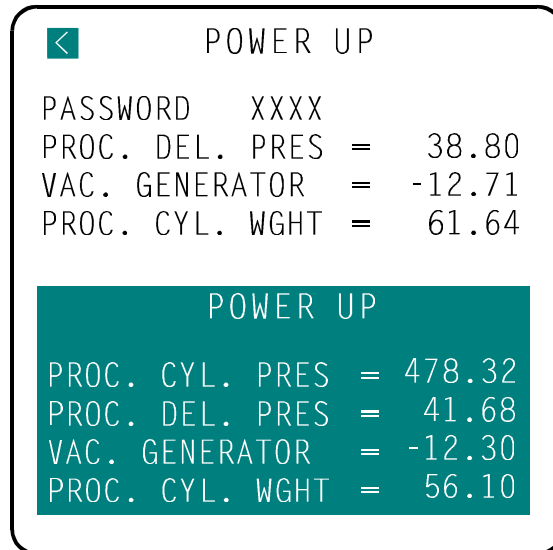

Press      



**Note:** Using numbers only for passwords eliminates the need to use the  and  keys to enter passwords.

If an improper password is entered, the screen will display:

Note the left arrow in the top left corner of the screen. If using a dual controller, the left arrow would show up if the left side of the controller has keypad access or control. If the right side has keypad access or control, the right arrow on the bottom half of the screen is displayed.

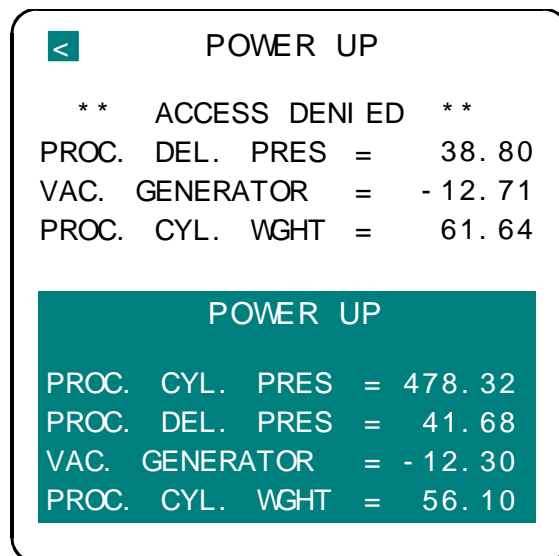

To change sides, use the  (up arrow) and  (down arrow) keys.



## Section 3: Operating Procedures

The right or left side must be selected before requesting the Main Menu and entering your password.

If the password is correct, the screen will display the main menu:

Use the  and  keys to highlight a menu choice.

Press  to begin the highlighted sequence.

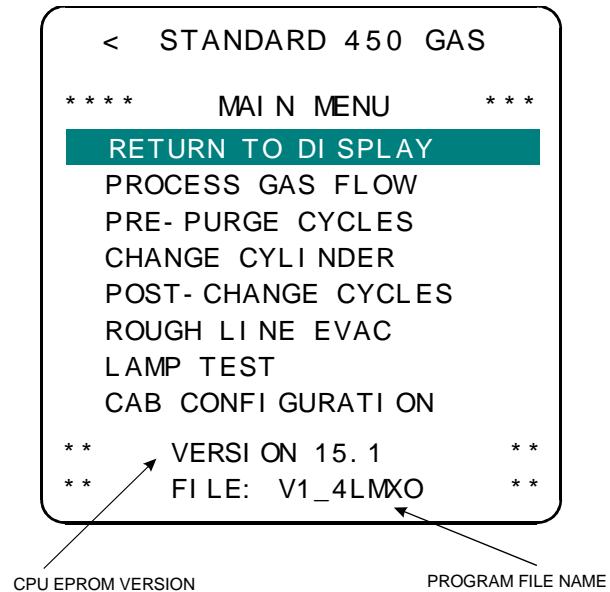

### 3.3 Process and Purge Cylinder Procedures

Prior to performing process or purge cylinder procedures, read and understand Compressed Gas Association Technical Bulletin, CGA, TB-9, 1993, Guidelines for the Proper Handling and Use of the CGA Series "Ultra High Integrity Service" Connections.



*Only operators trained in the following procedures and the hazardous gas system are allowed to change cylinders.*



*High pressure gas cylinders can be extremely hazardous when not handled properly. Follow the procedures in this section to prevent personal injury or death.*



*The procedures listed in this section are intended to be used in conjunction with the purge and cylinder change functions of the cabinet controller. Do not use these procedures independently.*

#### 3.3.1 Inert Purge Gas Cylinder Change Procedure

This procedure will normally be done after "PRE-PURGE CYCLES" in conjunction with a process gas cylinder change.



*Before approaching a hazardous gas cabinet for a cylinder change, verify that there are no alarm labels displayed on the LCD and that the exhaust system is functioning correctly. Only operators trained in these procedures and the hazardous gas system are allowed to change cylinders.*



### **3.3.1.1 Empty Purge Gas Cylinder Removal**

1. Check and record the required information on the Process Gas Cylinder Change Checklist (found on page 3-26) each time a cylinder is changed.



*Do not proceed if there are any alarm labels displayed on the LCD, the exhaust system is not working or pressures appear abnormal.*

2. Open access window.
3. Close purge gas cylinder valve (fully clockwise).
4. Close manual valve MV-10.
5. Slowly open manual valve MV-13, to vent purge gas within pigtail. Close MV-13.
6. Through the access window, loosen the pigtail cylinder connection from the cylinder valve using the proper wrench. Be sure to support the connection and pigtail tubing.
7. Close access window.
8. Don the required Personal Protective Equipment (PPE) prior to opening cabinet door.
9. Reverify that exhaust system is working.
10. Open gas cabinet door.
11. Recheck that cylinder valve and manual valve MV-10 are closed.
12. Fully remove pigtail cylinder connection from cylinder valve.
13. Install cylinder valve protection cap.
14. Install pigtail cylinder cap/plug onto pigtail connection.
15. Unbuckle cylinder strap and remove cylinder from cabinet.
16. Place cylinder in appropriate cart and strap in place. Place "EMPTY" tag on cylinder and return cylinder to the appropriate cylinder storage area.

### 3.3.1.2 Full Purge Gas Cylinder Installation

1. Verify that the replacement cylinder is identical to the purge gas cylinder that was removed.



*Never attempt to replace specified gas with another gas without consulting equipment supplier. Incompatible gases could cause fires, explosions or extremely corrosive or toxic compounds.*

2. Position full cylinder in gas cabinet, and strap loosely. Remove valve protection cap.



*If a valve protection cap is extremely difficult to remove, do not apply excessive force or pry the cap loose. Attach a label to the cylinder identifying the problem. Obtain another cylinder. Do not attempt to open a frozen cap as this would damage the cylinder valve and could result in personal injury or death.*

3. Check that the cylinder valve is tightly closed.
4. Check valve outlet area for contamination or damage. Do not attempt to use gas cylinder with damaged or contaminated valve outlet. Replace the cylinder and tag the defective cylinder indicating the problem.
5. Position valve outlet so that it lines up properly with the pigtail cylinder connection and tighten cylinder strap.



*Do not rotate cylinder by holding cylinder valve handle. This may open the cylinder valve and cause a high pressure gas leak which could result in personal injury or death.*

6. Remove pigtail cap/plug from pigtail cylinder connection.
7. Thread cylinder nut hand tight into/onto clean undamaged cylinder valve outlet. Be careful not to cross thread connections.

8. Tighten nut using appropriate tools to support pigtail. Do not apply excessive torque. Recommended torque:  
SS CGA to Brass Valve 80 ft. lbs.  
SS CGA to SS Valve 90 ft. lbs.  
DISS CGA to DISS Valve 35 ft. lbs.
9. Close cabinet door.

### **3.3.1.3 CGA Connection Leak Check (Purge Cylinder)**

1. Open access window.
2. Slowly open purge cylinder valve to fill pigtail and purge panel with purge gas. If the system is equipped with a purge cylinder transducer, "PURGE CYL PRESS" on the LCD screen should show full cylinder pressure.
3. Close cylinder valve.
4. Observe "PURGE CYL PRESS" for any pressure decay for five (5) minutes.
5. If there is no decay, the CGA connection is not leaking at a detectable level. Proceed to step 7.
6. If there is a pressure drop, a leak is indicated.
  - a. Slowly open manual valve MV-13 to completely vent purge gas pressure in pigtail.
  - b. Close valve, MV-13.
  - c. Remove purge cylinder from the pigtail.
  - d. Reinstall the purge cylinder (reference Section 3.3.1.2 "Full Purge Gas Cylinder Installation on pages 3-12 and 3-13.)
  - e. Retest following steps 1 through 5 in Section 3.3.1.3.
  - f. If leak persists, remove cylinder (reference Section 3.3.1.1 "Purge Gas Cylinder Removal Procedure" on page 3-11.)
  - g. Remember to mark the cylinder "FAULTY, BAD CYLINDER CONNECTION."

7. With suitable means (helium mass spectrometer, thermal conductivity detector, or liquid leak detector - as specified for area), inspect the cylinder connection and pigtail connection for leakage. Pay particular attention to the point where the nipple passes through the nut.

#### **3.3.1.4 Putting Purge Gas Cylinder On-Stream**

1. Open access window and open purge cylinder valve.
2. Slowly open manual valve MV-13 and quickly close to remove air from pigtail.
3. Slowly open manual isolation valve, MV-10, to regulator.
4. Adjust the purge gas regulator, PCV-2, to 80-90 psig delivery pressure (PI-4 or PT-4).
5. Open manual valve MV-11 if present.
6. Close access window.
7. The inert purge gas system is now ready for use.

### 3.3.2 Process Gas Cylinder Procedures

#### 3.3.2.1 Empty Process Gas Cylinder Removal (Prior to Removal)

This procedure assumes that a process gas cylinder and an inert purge gas cylinder are in place and operating.



*Before approaching a hazardous gas cabinet for a cylinder change, verify that there are no alarm labels displayed on the LCD and that the exhaust system is functioning correctly. Only operators trained in these procedures and the Gasguard 450 hazardous gas system are permitted to change cylinders. The appropriate Personal Protective Equipment (PPE) must be worn when performing any Process Cylinder Procedures. See Section 1.2 of this manual for the appropriate PPE. There are a number of system verification checks performed during the automatic cycle purge. If a "fault" or "shutdown" occurs, the operator must fully understand the indications. Under no circumstances should the cycle be restarted or continued until it is verified to be in a safe condition.*

1. Confirm with operating personnel that the process gas can be shut off before initiating stop process gas.
2. On the Main Menu screen of the LCD, highlight "PROCESS GAS FLOW".
3. Press 

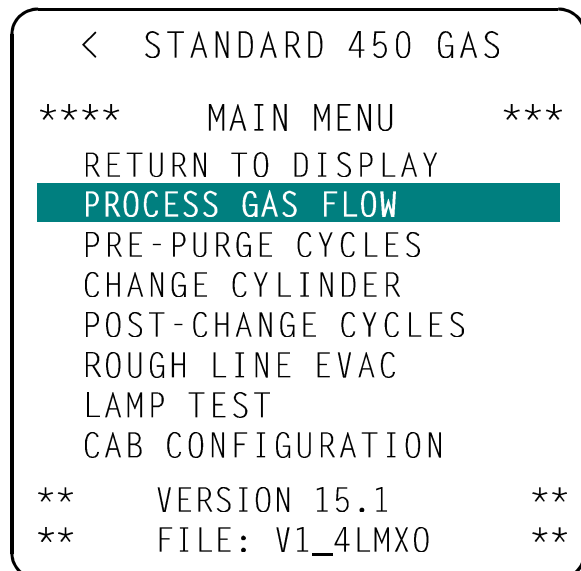

- Check and record the following information on the Process Gas Cylinder Change Checklist (found on page 3-26) each time a cylinder is changed.

Pressure readings on  
 "PROCESS CYL PRESS"(PT-1)  
 "PROCESS DEL PRESS" (PT-2)  
 "PROCESS CYL WEIGHT" (if scale  
 is present)

**PROCESS GAS STOPPED**

PROC. CYL. PRES = 111.70  
 PROC. DEL. PRES = 38.80  
 VAC. GENERATOR = -12.62  
 PROC. CYL. WGHT = 9.15

**POWER UP**

PROC. CYL. PRES = 478.32  
 PROC. DEL. PRES = 41.68  
 VAC. GENERATOR = -12.30  
 PROC. CYL. WGHT = 56.10

Observe that all valves are closed, (green) and note any shutdown or warning light and any other comments about the condition of system.

Proceed to trouble shooting section for corrective action if there are any shutdown or warning conditions. Notify your supervisor immediately.

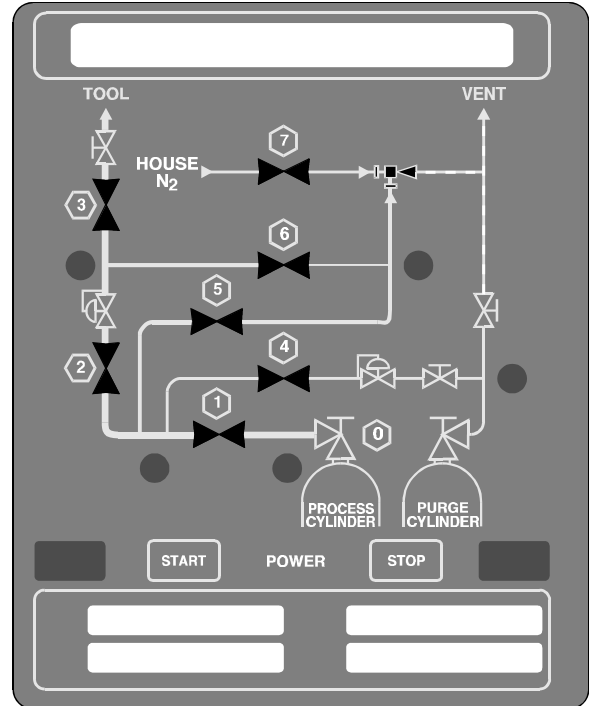

= OPEN RED  
 = CLOSED GREEN

## Section 3: Operating Procedures

5. On the Main Menu screen, highlight "PRE PURGE CYCLES".
6. Press **START**
7. Follow prompted manual steps on the LCD screen.

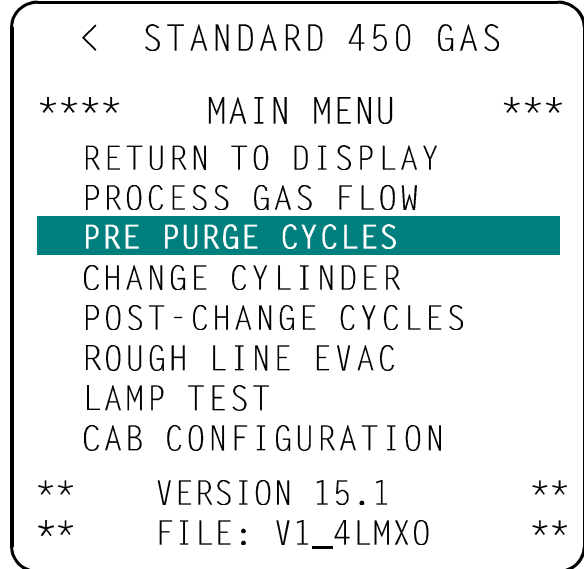

The following valves will sequence on the display during the high pressure purge cycles.

First, the tubing between the high pressure valve (V-2) and the process cylinder valve is evacuated.

The valves will look like the illustration on the right.

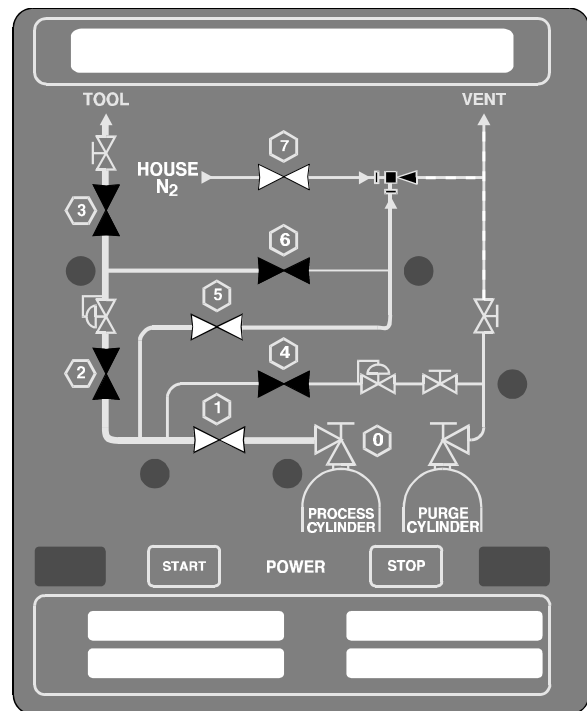

 = OPEN  
RED

 = CLOSED  
GREEN

The high pressure tubing will then be "flush" purged.

The valves will appear as illustrated to the right.

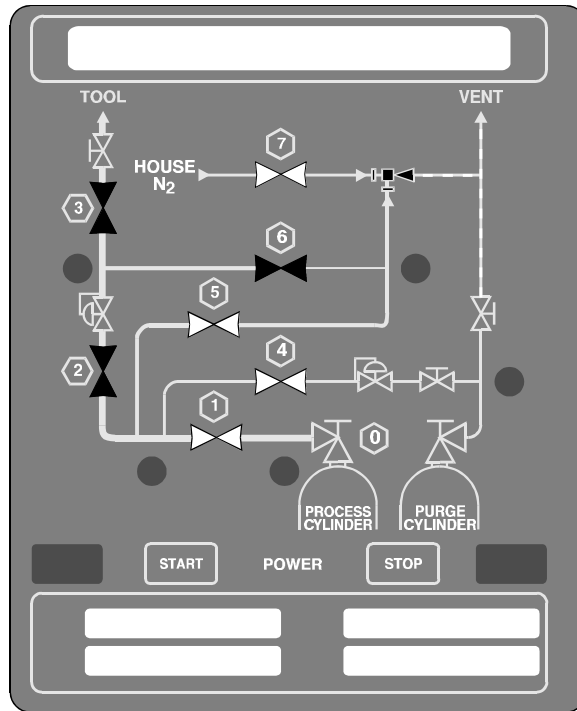

△ = OPEN RED      ▲ = CLOSED GREEN

The tubing will then be pressurized with purge gas.

The valves will appear as illustrated to the right.

This sequence of evacuation and pressurization will be repeated until the configured number of cycles is completed.



### 3.3.2.2 Empty Process Gas Cylinder Removal

1. Verify that the pre-purge is complete.
2. On the Main Menu screen, highlight "CHANGE CYLINDER".
3. Press **START**
4. Follow prompted information on the screen.

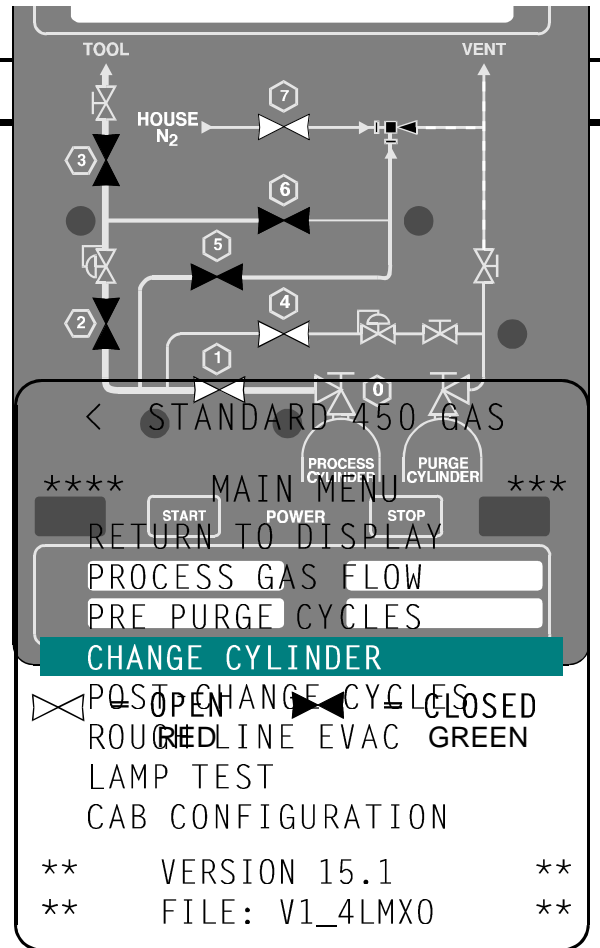

On the majority of systems, a trickle purge of the high pressure tubing will begin and continue until you press **ENTER** indicating the cylinder change is complete.

The valves will appear as illustrated to the right.

5. ***Don the self-contained breathing apparatus and all other Personal Protective Equipment (PPE) required, if not done already. See Section 1.2 for details on the required PPE.***
6. Reverify that exhaust system is working.
7. Open access window.

8. Recheck that process cylinder valve is closed.

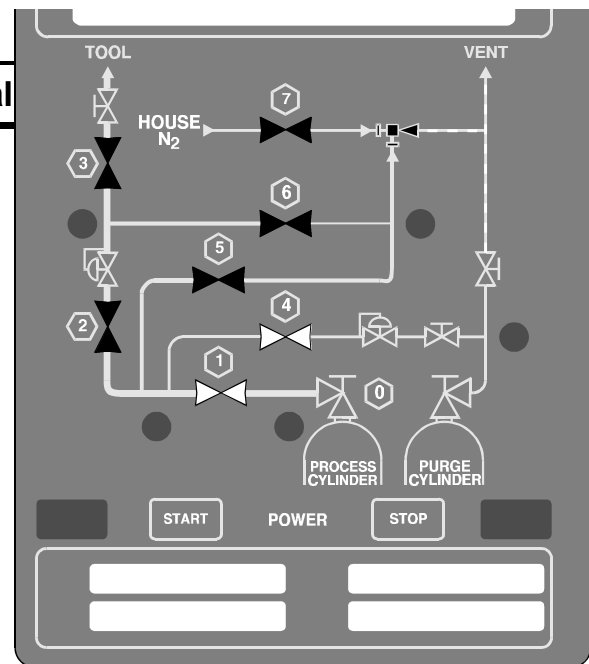

 = OPEN  
RED

 = CLOSED  
GREEN



***Do not use a wrench or other devices to close diaphragm type cylinder valves. This could cause valve failure. The maximum torque on diaphragm type cylinder valves is 12 foot/pounds. Certain gases are supplied with cylinder valves without handwheels. Use the proper tool from your gas supplier to operate these valves.***

9. Loosen and remove the pigtail cylinder connection from the gas cylinder using appropriate tools to support the connection and pigtail tubing. Note proper direction of rotation, fittings with left-hand threads have notched hex corners. Observe and listen for any sound of gas leakage. Close door immediately if the process gas cylinder valve is leaking and evacuate the area.

***Note: Portable leak detectors are available for many of the hazardous gases used by the electronics industry. It is recommended that these are provided to the operator to detect very small leaks from the cylinder valve at this step.***

10. Install cylinder valve outlet plug/cap securely into/onto process cylinder valve outlet.



***This valve outlet cap must be used on all toxic, corrosive and pyrophoric gases. Consult your supplier if there is no cap on these gas cylinders.***

11. Install pigtail cap/plug onto pigtail cylinder connection. This step is not necessary if the new cylinder is going to be installed immediately.
12. Open gas cabinet door.
13. Loosen cylinder holding strap but do not unbuckle.
14. Install cylinder valve protection cap.
15. Unbuckle cylinder strap and remove cylinder from cabinet.
16. Place cylinder in appropriate cart and strap in place. Place "EMPTY" tag on cylinder and return cylinder to the appropriate cylinder storage area.

### **3.3.2.3 Full Process Gas Cylinder Installation**



*The required Personal Protective Equipment (PPE) must be worn when performing any process cylinder procedures. Refer to Section 1.2 of this manual for the required PPE.*

1. Verify that the cylinder contains the same gas as the label on the gas cabinet and process panel.



*Never attempt to replace a specified gas with another gas without consulting equipment supplier. Incompatible gases could cause fires, explosions or extremely corrosive or toxic compounds.*

2. Position full cylinder in gas cabinet, and strap loosely. Remove valve protection cap.



*If a valve protection cap is extremely difficult to remove, do not apply excessive force or pry the cap loose. Attach a label to the cylinder identifying the problem. Obtain another cylinder. Do not attempt to open a frozen cap as this would damage the cylinder valve and could result in personal injury or death.*

3. Check that the cylinder valve is tightly closed.
4. Slowly remove valve outlet plug/cap on the cylinder. Listen and observe for any sign of leakage. If you notice leakage, immediately retighten cap, close the cabinet door and evacuate the area. Follow established emergency response procedures. Cylinders with valve leaks are defective and should be returned to supplier.

*Note: Portable leak detectors are available for many of the hazardous gases used by the electronics industry. It is recommended that these are provided to the operator to detect very small leaks from the cylinder valve at this step.*

5. Check valve outlet area for contamination and damage. Do not attempt to use a gas cylinder with a damaged or contaminated valve outlet. Tag the cylinder as "FAULTY", and obtain another cylinder.



*Verify that the proper restrictive flow orifice is installed in the cylinder valve outlet, as indicated on the cylinder tag. Use a wire gauge of appropriate size.*

6. Position cylinder so that the valve outlet lines up with the pigtail cylinder connection and tighten cylinder strap.



*Do not rotate cylinder by holding cylinder valve handle. This may open the cylinder valve and cause a high pressure gas leak which could result in personal injury or death.*

7. Remove pigtail cap/plug from pigtail connection.
8. Install new washer/gasket on those cylinder connections that require washers/gaskets.
9. Thread pigtail cylinder nut hand tight into/onto clean undamaged cylinder valve outlet noting proper direction of rotation. Be careful not to cross thread connections.
10. Tighten nut using proper wrench. Be sure to support pigtail. Do not apply excessive torque. Recommended torque: CGA with Gasket 35 ft. lbs.

## Section 3: Operating Procedures

SS CGA to Brass Valve 80 ft. lbs.  
SS CGA to SS Valve 90 ft. lbs.  
DISS CGA to DISS Valve 35 ft. lbs.

11. Close cabinet door.
12. The system is now ready for "POST PURGE CYCLES".



*Do not open cylinder valve at this time. A cylinder connection leak check must be completed first, followed by the Post Purge procedure.*

### 3.3.2.4 Full Process Cylinder Purge (After Installation)

1. On the Main Menu screen, highlight "POST PURGE CYCLES".
2. Press **START**
3. Follow any steps that may be prompted on the screen.

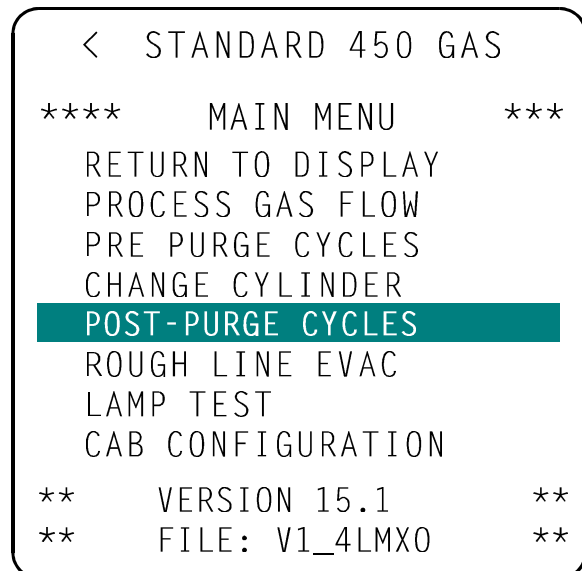

# Gasguard® 450 System Operation Manual

The following valves will sequence on the display during the high pressure cycles.

First, the tubing between the high pressure valve (V-2) and the process cylinder valve is evacuated.

The valves will look like the illustration on the right.

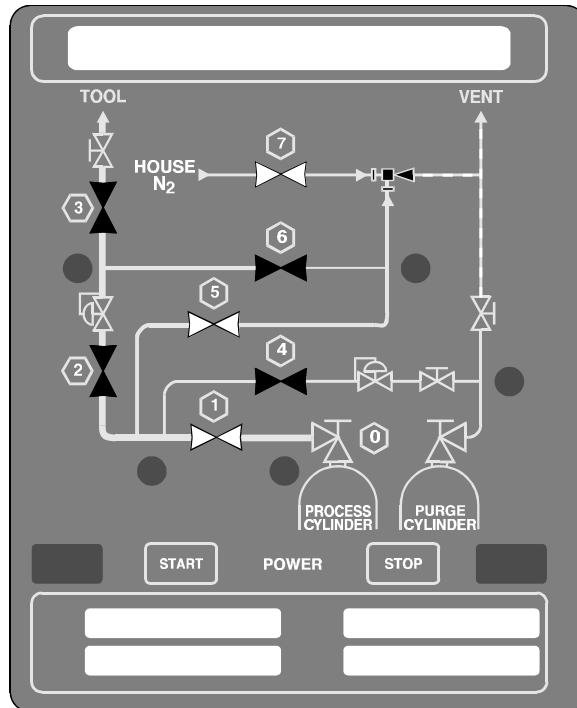

☒ = OPEN  
RED  
GREEN

☒ = CLOSED

### Section 3: Operating Procedures

The high pressure tubing will then be "flush" purged.

The valves will appear as illustrated to the right.

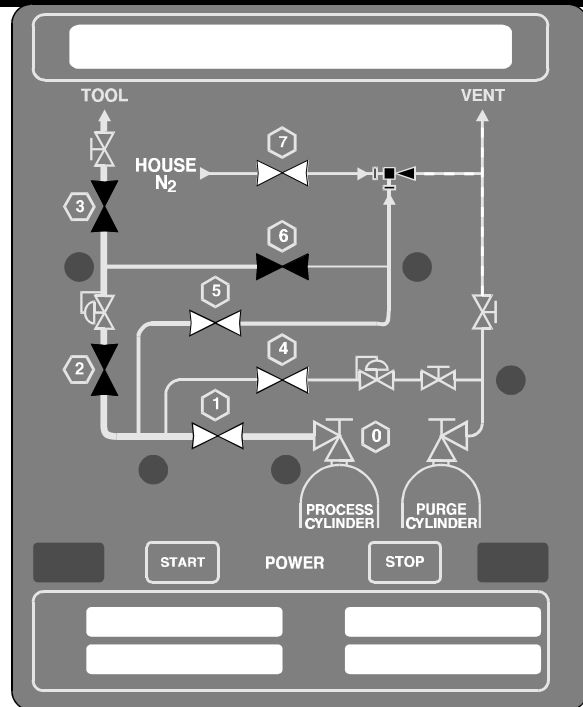

◇ = OPEN RED      ◇ = CLOSED GREEN

The tubing will then be pressurized with purge gas.

The valves will appear as illustrated to the right.

This sequence of evacuation and pressurization will be repeated until the configured number of cycles is completed.

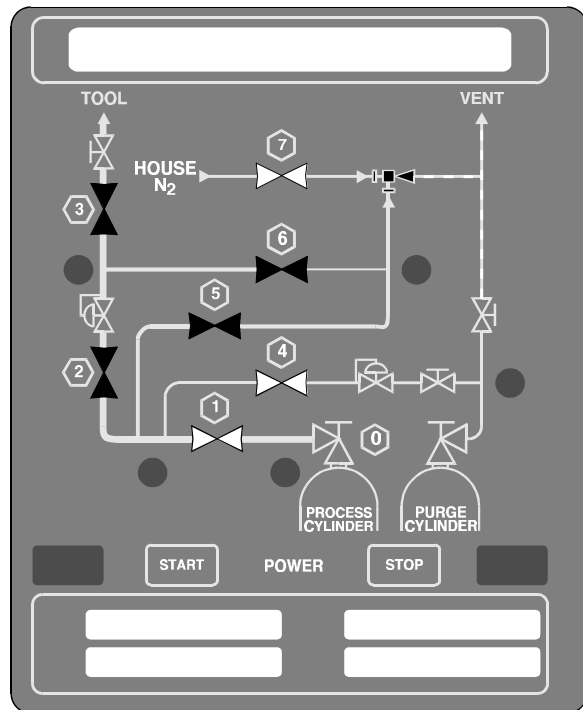

◇ = OPEN RED      ◇ = CLOSED GREEN

**3.3.2.5 Process Gas Flow**

1. On the Main Menu screen of the LCD, highlight "PROCESS GAS FLOW".
2. Press **START**
3. Follow the steps prompted on the screen.

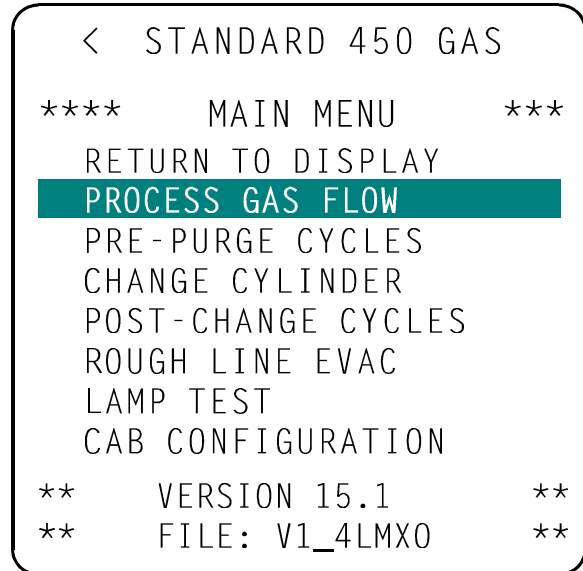

4. Process gas is now flowing to the process equipment.

The valves on the graphic display will appear as illustrated to the right.

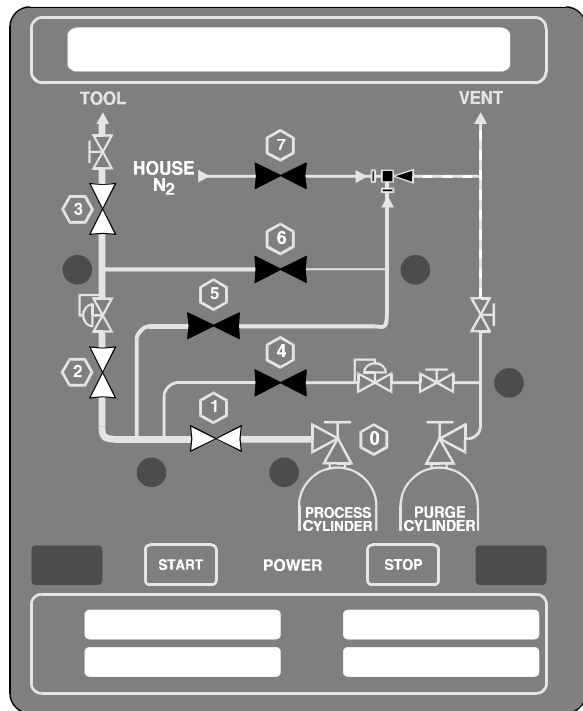

 = OPEN  
 = CLOSED  
 RED GREEN

**PROCESS GAS CYLINDER CHANGE CHECKLIST**



## Section 3: Operating Procedures

Customer Cabinet No. \_\_\_\_\_

Gas Service \_\_\_\_\_



***CLOSE CYLINDER VALVE BEFORE STARTING PURGE SEQUENCE.***

***WEAR APPROPRIATE PERSONAL PROTECTIVE EQUIPMENT AS DETAILED IN SECTION 1.2 OF THIS MANUAL WHEN CHANGING OR INSTALLING A TOXIC GAS CYLINDER.***

***RECHECK THAT CYLINDER VALVE IS TIGHTLY CLOSED BEFORE LOOSENING CGA CONNECTION FROM CYLINDER VALVE.***

Date	Time	Cabinet Interior OK (Leakage Corrosion)	Cabinet Exhaust Working	Cylinder Valve Closed	Proper RFO Installed		Process Gas Pressure		Purge Gas Pressure		Cylinder Weight	Operator Initials
							PI1	PI2	PI3	PI4		
						Start						
						Finish						
						Start						
						Finish						
						Start						
						Finish						
						Start						
						Finish						
						Start						
						Finish						
						Start						
						Finish						
						Start						
						Finish						

### 3.4 New System Startup Procedure



*If the system is installed in a NEC Class I, Division II hazardous location, do not apply power to the cabinet controller until the controller enclosure has been purged for at least 10 minutes at approximately 6 SCFH. Refer to steps 4 and 5 below. This complies with NFPA 496 regarding electrical equipment enclosures. Failure to do so could result in the ignition of any flammable gas which may be present.*

1. Verify that the system is ready for startup by completing the startup checklist in the installation manual. Check that the Gasguard 450 system and all plant piping have been leak checked with a helium mass spectrometer in accordance with the customer's specified procedure. Check that the Gasguard 450 system has been functionally checked after installation.
2. Check that the cabinet exhaust system and hazardous gas disposal system (pollution abatement) are operating.
3. Verify that house nitrogen pressure is between 75-95 psig.
4. In Class I, Division II hazardous locations, turn on and adjust purge gas flow to the cabinet controller. The flow indicator should indicate approximately 6 SCFH (hazardous locations only).
5. After purging the controller for at least 10 minutes, turn on electrical power to the controller.



*The Gasguard 450 system is supplied with an internal controller purging means that meets NFPA 496, Type Z purging requirements for use in NEC Class I, Division II hazardous location. Type Z purge does not meet Class I, Division I NEC requirements.*

6. Press **RESET** and **ACK** to initialize the controller on power up. No alarms should be present. If alarms are present and cannot be cleared by pressing

## Section 3: Operating Procedures

**ACK** and then **RESET**, do not continue. Follow the troubleshooting procedures in Section 4. If needed contact your Air Products factory representative for assistance.

7. Check that all automatic valves indicate closed position (Green). They should appear as illustrated to the right.
8. Check that regulators are closed (knob rotated fully counterclockwise).
9. Ensure the process pigtail connection cap/plug is installed and tight.
10. Install an inert purge gas cylinder in the cabinet. Refer to Section 3.3.1.2 Full Purge Gas Cylinder Installation.

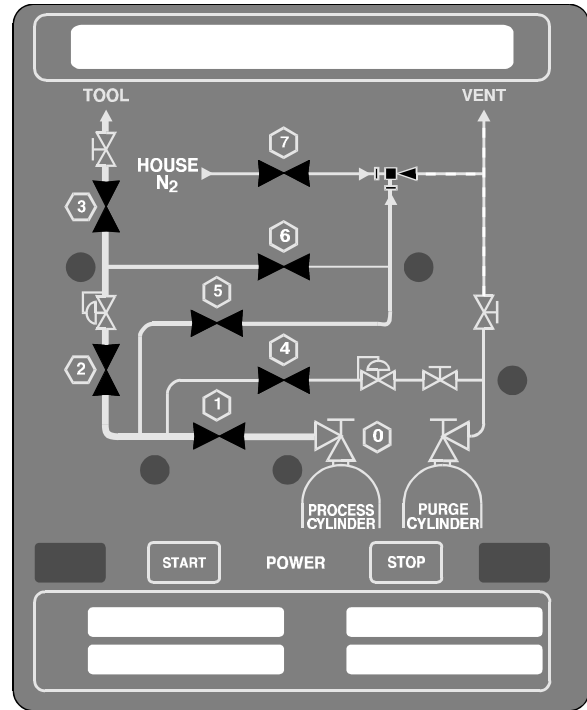

△ = OPEN RED      ▴ = CLOSED GREEN

11. Select Menu and enter the password.
12. On the Main Menu screen, highlight "PRE PURGE CYCLES".
13. Press **ENTER**
14. Follow the prompts on the screen.

```
***** MAIN MENU *****  
RETURN TO DISPLAY  
PROCESS GAS FLOW  
PRE PURGE CYCLES  
CHANGE CYLINDER  
POST-CHANGE CYCLES  
ROUGH LINE EVAC  
LAMP TEST  
CAB CONFIGURATION  
** VERSION 15.1 **  
** FILE: V1_4LMXO **
```

## Section 3: Operating Procedures

15. When the screen indicates "PRE PURGE CYCLES" is complete, highlight "CHANGE CYLINDER".
16. Press **START**
17. Follow the prompts on the screen.
18. Refer to Section 3.3.2.3 Full Process Gas Cylinder Installation.

```
< STANDARD 450 GAS
**** MAIN MENU ****
RETURN TO DISPLAY
PROCESS GAS FLOW
PRE PURGE CYCLES
CHANGE CYLINDER
POST-CHANGE CYCLES
ROUGH LINE EVAC
LAMP TEST
CAB CONFIGURATION
** VERSION 15.1 **
** FILE: V1_4LMX0 **
```

19. Select Menu and enter the password.
20. Select "POST PURGE CYCLES" from the Main Menu.
21. Press **START**
22. Follow any prompts that may be on the screen.

```
< STANDARD 450 GAS
**** MAIN MENU ****
RETURN TO DISPLAY
PROCESS GAS FLOW
PRE PURGE CYCLES
CHANGE CYLINDER
POST-PURGE CYCLES
ROUGH LINE EVAC
LAMP TEST
CAB CONFIGURATION
** VERSION 15.1 **
** FILE: V1_4LMX0 **
```



*Before proceeding further, verify that process equipment and facility piping is ready to receive process gas.*

23. When the screen indicates "POST PURGE CYCLES" is completed, re-enter the Main Menu and select "PROCESS GAS FLOW".
24. Press **START**
25. Adjust the process gas regulator, through the access window, to the desired delivery pressure.
26. Process gas is now flowing to the process equipment.

**NOTE: Operator prompts are "Flashed" on the LCD screen.**

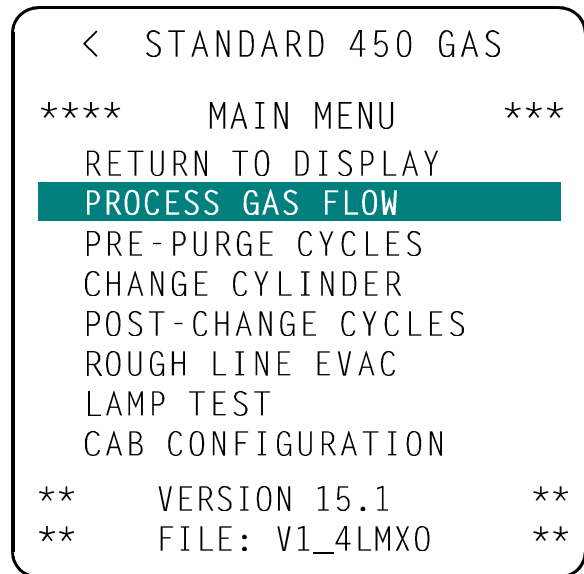

With process gas flowing the valves on the graphic display will appear as illustrated to the right.

27. Record Process Conditions - cylinder weight if scale is present, PI-1, PI-2, PI-3 and PI-4 on the Process Gas Cylinder Checklist.

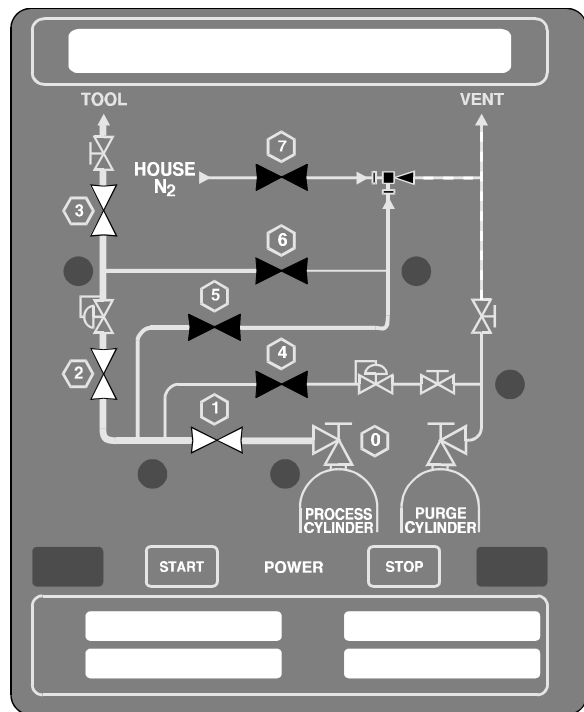

= OPEN RED
 = CLOSED GREEN

## 3.5 Manual Operation



*Only experienced operators should operate the cabinet in Manual Mode. Operating valves out of their proper sequence could potentially cause damage to the product by interrupting or providing insufficient gas flow. Manual operation should not be used for process gas flow, as critical shutdown alarms may be disabled in Manual Mode.*

Manual mode provides a means of flowing purge gas through the purge and process gas panels during cabinet installation and pre-start-up procedures. It also provides a means of flowing purge gas while maintenance or repairs are being performed.

*NOTE: Access to Manual Mode is not permitted when certain digital Shutdown alarms are present.*

### 3.5.1 How to Operate in Manual Mode











*Operating in Manual Mode can cause the following hazards which can result in PERSONAL INJURY OR DEATH.*

- Process gas could be forced into the purge panel and/or purge gas cylinder.*
- Opening purge panel valves when high pressure process gas is present.*
- High pressure gas could be unintentionally vented.*
- Opening vent valves when high pressure process gas is present.*

*NOTE: Due to the potential hazards listed above, Manual Mode operation requires a second or higher level security code.*

**NOTE:** *Opening high pressure vent valves when high pressure gas is present could cause damage to the vent line pressure device, if installed.*

1. On dual controllers, use the  and  keys to activate the left or right controller. The active side is indicated by an arrow on the screen and a lit yellow LED below the screen.
2. Press , then  to request the Main Menu.
3. Type in the password using shifted and unshifted keys as required. Press .
4. From the Main Menu screen, highlight "CABINET CONFIGURATION".
5. Press .
6. From the configuration menu, highlight "MANUAL MODE".
7. Press .
8. Operate valves referring to Section 3.5.2 below.
9. To exit MANUAL MODE, press  then . Any open valves will close at this time.

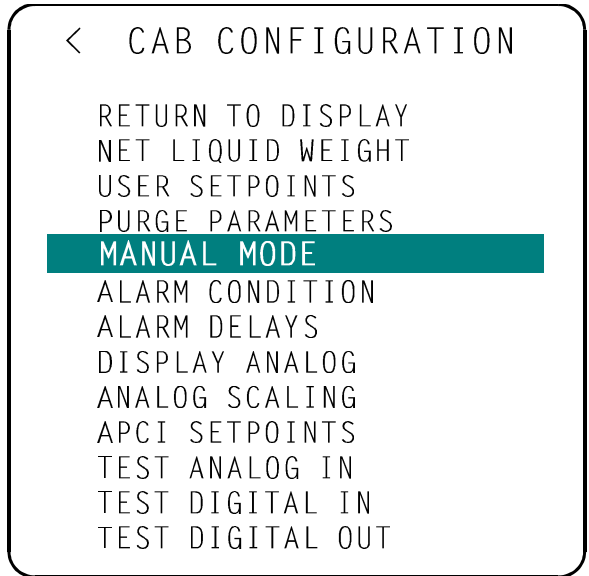
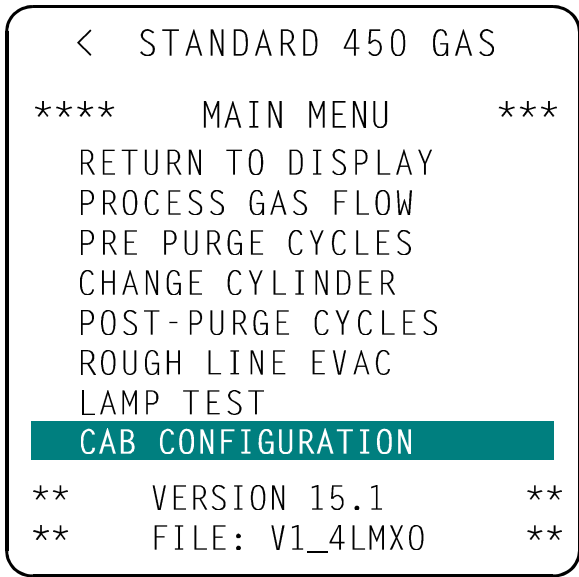





### 3.5.2 How to Open and Close Valves



There are two ways to open and close valves in Manual Mode. The simplest is to press the hexagonal membrane switch located next to the valve symbol on the graphic display. Pressing the switch toggles the valve from OPEN to CLOSED or CLOSED to OPEN.

An alternate method is to use the keypad.

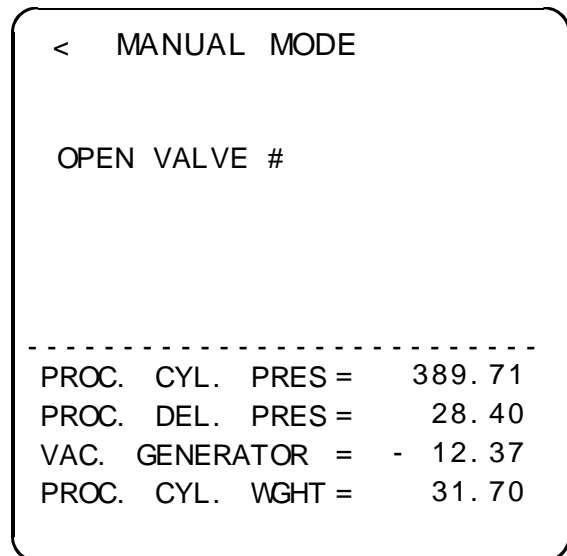

#### To open a valve:

1. Press  then . The screen prompts: OPEN VALVE #.
2. Type the number of the valve you wish to open. Press .
3. The valve will open.



*Note: The operator may be prompted to confirm the opening of certain valves by pressing  then  for yes. This prompt is a reminder to check for potentially dangerous situations prior to opening these valves.*

**To close a valve:**

1. Press , then . The screen prompts: CLOSE VALVE #.
2. Type the number of the valve you wish to close. Press .
3. The valve will close.

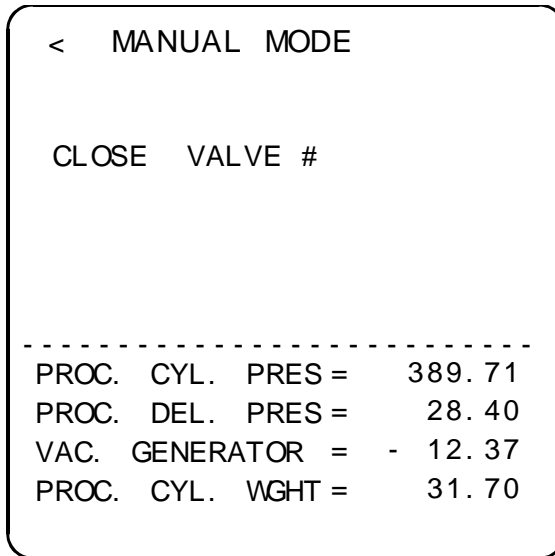

*Cabinet must not be left unattended in Manual Mode, as access to the system in Manual Mode is open to anyone.*

### 3.5.3 General Principles of Manual Operation

Open valves in sequence starting at the first valve downstream of the pressure source and continuing to the next valve in sequence.

For vacuum operation, open the valve closest to the vacuum source and continue to open the next valve in sequence.

Close valves in reverse order.

Monitor pressures on the LCD frequently.

Consider all possible results before opening or closing a valve.

## **3.6 Cabinet Configuration**

Certain Gasguard 450 controller files may be modified using a second or higher level security code. These modifications are referred to as the cabinet configuration.

The cabinet configuration may be accessed from the CAB CONFIGURATION option on the Main Menu. From the CAB CONFIGURATION menu, you may display some configurable parameters and change user configurable parameters.

For safety considerations, most configuration parameters may be changed only by Air Products technical personnel.

The paragraphs below describe the parameters that you may view and/or change.

### **Net Liquid Weight**

This option displays the net weight of liquid cylinders. You may enter or change this value. A value of "0" (zero) in this file will cause the scale to display gross cylinder weight.

### **User Setpoints**

This option displays the alarm setpoints that you may change and their current values. These setpoints typically include:

- Low Process Cyl.
- Low Process Cyl.
- Regulator Creeping (may also serve as a high pressure delivery alarm)
- Low Process Del.
- Low Cyl. Weight
- Low Cyl. Weight

## Purge Parameters

This option displays the current values for the purge parameters. You may increase these values, but may not decrease them below their pre-programmed minimum. The values displayed below are the Air Products and Chemicals, Inc. minimums.

- High Pressure Cycles 20
- Low Pressure Cycles 20
- Subcycle 3 10
- Subcycle 4 10
- Helium Leak Inboard 1
- Helium Leak Outboard 1

## Manual Mode

This option allows you to operate the cabinet valves independently during installation, pre-startup and maintenance activities. See Section 3.5 for more information on Manual Mode.



*Only experienced operators should operate the cabinet in Manual Mode. Operating valves out of their proper sequence could potentially cause damage to the product by interrupting or providing insufficient gas flow. Manual operation should not be used for process gas flow as critical shutdown alarms may be disabled in Manual Mode.*

## Alarm Condition

This option displays a list of alarms and the condition when an alarm will occur. You may not change this list.

## Alarm Delays

This option displays the delay time for each alarm. You may not change the delay times.

**Display Analog**

This option displays a list of analog inputs and indicates with a Y or N whether the input is displayed on the LCD screen. This option is display only.

**Analog Scaling**

This option displays the following information about each analog input:

Input used?	Y or N
Range	4-20 mA
Minimum	0.00
Maximum	0.00

You may not change this list.

**APCI Setpoints**

This option displays the Air Products configurable alarm setpoints. You may not alter these setpoints.

**Test Analog In**

This option displays a list of the analog inputs and their current values. The current value may be used to determine if the analog device is providing accurate output (controller input).

**Test Digital In**

This option displays a list of the digital inputs and their current state. The state may be used to determine if the digital device is operating properly. This screen is very useful for system testing and troubleshooting.

## Test Digital Out

This option displays a list of the digital outputs and their current values. Outputs may be forced "on" (energized) or "off" (deenergized) to determine if the output is operating properly.

This file operates in a similar manner to Manual Mode operation as described in Section 3.5. It is the customer's responsibility to adhere to all operational warnings in Section 3.5 when performing the Digital Out Test.



*Extreme care must be taken when forcing a digital output either on or off. When checking a digital output signal to a solenoid valve, energizing the output would also open the associated pneumatic valve on the process panel. The operator must understand the consequence of opening any valve before he performs a digital out test to any solenoid valve. There is no confirmation request in Digital Out Test, as a reminder, like that which is used in Manual Mode for critical valve operation.*

## Section 4: Troubleshooting

---

This section explains how you can identify malfunctions present in the system.



*Troubleshooting is only to be performed by trained people who understand the hazards of the system.*



*Personal injury or death may result if proper personal protective equipment (PPE) is not worn when performing troubleshooting. See Section 1.2 of this manual for the proper PPE.*



*Turn off the electrical power to the system before performing controller maintenance.*



*Before attempting to service the system components, close the cylinder valve(s), vent all pressure in the system, and purge all lines that have contained process gas. Tag out and lock out the cylinder valve(s) following the procedure in Section 1.4 (found on pages 1-18 to 1-21 of this manual) to prevent opening while service is being performed. Once the repairs have been made, follow the start-up procedure, in Section 3.4 of this manual.*

This section explains how you can identify malfunctions present in the system. The format of this section is the presentation of a problem, possible cause and possible solutions.



*Before performing troubleshooting, review the Safety section and read the warnings on page 4-1. If at any time during troubleshooting, you are unsure what to do next, DO NOT CONTINUE. Contact Air Products and Chemicals.*

## **4.1 System Shut Down, No Lights on Controller**

<b>Possible Source of Problem</b>	<b>Test</b>	<b>Solution</b>
Electrical power failure	Check power supply to system.	Restore specified power to electrical control panel.
	Check fuses.	Replace as required.

## **4.2 No or Low Purge Gas Pressure**

<b>Possible Source of Problem</b>	<b>Test</b>	<b>Solution</b>
Closed purge gas cylinder valve	Check position of cylinder valve.	Open cylinder valve, pressure should indicate the current purge cylinder pressure.
Low purge gas cylinder pressure	Check cylinder pressure.	Change cylinder following Cylinder Change Out Procedures found in Section 3.3.1 of this manual.



<b>Possible Source of Problem</b>	<b>Test</b>	<b>Solution</b>
Instrument nitrogen supply not adequate	Check instrument nitrogen pressure.	Adjust instrument nitrogen to 75-95 psig.
Purge gas pressure regulator set incorrectly	Check setting on pressure regulator.	Set pressure regulator to correct delivery pressure (80-90 psig).
Purge gas pressure transducer(s) malfunctioning	Check input to controller, Check connections and signal from pressure transducers.	Repair connections, repair or replace transducer(s) as necessary.

### 4.3 No or Low Purge Gas Flow

<b>Possible Source of Problem</b>	<b>Test</b>	<b>Solution</b>
No or low purge gas pressure	See Section 4.2 above.	
Purge gas manual isolation valve(s) closed or partially closed	Check position of purge gas manual isolation valve(s).	Open fully.
Are any purge vent valves open?	Check position of all purge vent valves.	Close any purge vent valves if open.
Are purge gas pneumatic valves receiving sufficient pressure to open?	Check if instrument supply is adequate.	Adjust to 75-95 psig if necessary.

## 4.4 No or Low Process Gas Pressure

<b>Possible Source of Problem</b>	<b>Test</b>	<b>Solution</b>
Closed process gas cylinder valve	Check position of process gas cylinder valve.	Open cylinder valve, pressure should indicate process cylinder pressure.
Low process gas cylinder pressure	Check process gas cylinder pressure.	Change cylinder following Cylinder Change Out Procedures found in Section 3.3.2 of this manual.
Instrument nitrogen supply not adequate	Check instrument nitrogen pressure.	Adjust instrument nitrogen to 75-95 psig.
Process gas pressure regulator set incorrectly	Check setting on pressure regulator.	Set pressure regulator to correct metering pressure.
Process gas pressure transducer(s) malfunctioning	Check input to controller, Check connections and signal from pressure transducers. Check logs for previous pressure readings.	Repair connections, repair or replace transducer(s) as necessary.

## 4.5 No or Low Process Gas Flow

<b>Possible Source of Problem</b>	<b>Test</b>	<b>Solution</b>
No or low process gas pressure	See Section 4.4 above.	
Process gas manual isolation valve(s) closed or partially closed	Check position of process gas isolation valve(s).	Open fully.
Are any vent valves open?	Check position of all vent valves.	Close any vent valves if open.

## Section 4: Troubleshooting

<b>Possible Source of Problem</b>	<b>Test</b>	<b>Solution</b>
Are process gas pneumatic valves receiving sufficient pressure to open?	Check if instrument supply is adequate.	Adjust to 75-95 psig if necessary.

## 4.6 Typical Alarms

This section assumes that all devices are calibrated and functioning according to the manufacturer's specification. Contact your Air Products Technical Representative or the manufacturer should you need to obtain this information.



*Before performing troubleshooting, review the Safety section and read the warnings on page 4-1. If at any time during troubleshooting, you are unsure what to do next, DO NOT CONTINUE. Contact Air Products and Chemicals.*

*NOTE: Contact Air Products and Chemicals if the alarm displayed on the screen does not appear in this section.*

*NOTE: Contact Air Products and Chemicals for the procedure for calibrating the Span transducer.*

### 4.6.1 Excess Flow

Probable Cause	Corrective Action
High process gas flow due to mechanical failure or product surge.	Examine process gas system to locate cause of signal.
Excess flow switch stuck in the open position due to contamination or corrosion.	Perform purge cycles in accordance with Section 3.3.2.1 to attempt to remove any residual build-up in switch.

### 4.6.2 Low Pneumatic Pressure

Probable Cause	Corrective Action
Pneumatic supply to the controller is less than 65 PSIG.	Adjust pneumatic pressure to the controller to 75-95 PSIG.

## PT-1 (Process Cylinder Transducer) Alarms

The following are possible process cylinder transducer alarms.

### 4.6.3 Low Process Cylinder Pressure or Very Low Process Cylinder Pressure

Probable Cause	Corrective Action
Process cylinder is below the low and/or very low setpoint.	Follow the process cylinder change-out procedure found in Section 3.3.2 of this manual.
OR Cylinder valve is not open.	OR Ensure cylinder valve is open.

### 4.6.4 Low Vacuum at PT-1

Probable Cause	Corrective Action
Vacuum at PT-1 < -5 PSIG due to Vacuum Venturi supply pressure or flow requirement is insufficient.	Verify Venturi supply is 75-95 PSIG and that a flow rate of 50-60 SLPM can be achieved.
OR PT-1 path to vent is isolated either from a closed manual valve or an air operated valve in this path not actuating.	OR Visually inspect the panel for a closed manual valve in the path to vent and verify 75-95 PSIG of pneumatic supply pressure is being supplied to the controller.

### 4.6.5 Low Purge Pressure at PT-1

Probable Cause	Corrective Action
Purge pressure at PT-1 is less than 70 PSIG due to low purge delivery pressure.	Increase purge delivery to 80-90 PSIG.

### 4.6.6 High Pressure at Cylinder Connection (Diss, CGA, Keyed VCR, etc.)

#### Probable Cause

Process cylinder valve was accidentally opened prior to starting the change cylinder sequence or the post purge sequence.

#### Corrective Action

Ensure the process cylinder valve is closed and enter the Manual Mode file (according to the steps in Section 4 of this manual) and evacuate by opening V-7, V-5 and V-1 until PT-1 is less than -5 PSIG, reinitiate the sequence.

### 4.6.7 Standby Leak Detected

#### Probable Cause

Used on Auto Crossover Systems Only. This alarm monitors process gas retention while a panel is on "Standby." Probable causes are V-3, V-5 or V-6 are leaking across the seat.

#### Corrective Action

Remove pneumatic line hoses from these valves and verify absence of pressure. If pressure is present, this indicates a solenoid failure. Contact your Air Products Technical Representative. Perform a pre-purge sequence with the purpose of removing any debris that may be on the seat of the valves.

### 4.6.8 CGA Leaking

#### Probable Cause

Process gas CGA connection not properly tightened.

#### Corrective Action

***Personal protective equipment (PPE) MUST be worn when a leak is suspected.*** Appropriate PPE is detailed in Section 1.2 of this manual. Tighten pigtail cylinder connection per torque guideline, Section 3.3.2.3. If leak persists, advise supervisor or contact APCI.

### **4.6.9 Cylinder Leaking**

<b>Probable Cause</b>	<b>Corrective Action</b>
Process cylinder valve not completely closed.	Close cylinder valve. (Do not overtorque.) Reinitiate program sequence. If failed, assume cylinder valve is leaking and take appropriate emergency response.

## **PT-2 (Process Delivery Transducer) Alarms**

The following are possible process delivery transducer alarms.

### **4.6.10 High Process Delivery Pressure or Very High Process Delivery Pressure**

<b>Probable Cause</b>	<b>Corrective Action</b>
Process delivery pressure exceeded the high and very high setpoints	Decrease the process pressure regulator. Observe regulator for proper operation. If regulator will not maintain the setpoint, it may be "creeping". Contact your APCI Technical Representative.

### **4.6.11 Low Process Delivery or Very Low Process Delivery**

<b>Probable Cause</b>	<b>Corrective Action</b>
Process delivery pressure is below the low and/or very low setpoint.	Adjust process pressure regulator to the desired delivery pressure.

### **4.6.12 Low Vacuum at PT-2**

**Probable Cause**

**Corrective Action**

Vacuum at PT-2 is < -10 PSIG due to Vacuum Venturi supply pressure or flow requirement is insufficient.

Verify Venturi supply is 70-90 PSIG at a deliverable flow rate of 50-60 SLPM.

OR

OR

An air operated valve in the PT-2 path to vent is not actuating.

Ensure that 75-95 PSIG of pneumatic supply pressure is being supplied to the controller.

### **4.6.13 Low Purge Pressure at PT-2**

**Probable Cause**

**Corrective Action**

Purge pressure at PT-2 is < 10 PSIG due to low purge delivery pressure.

Increase purge delivery to 80-90 PSIG.

OR

OR

Process regulator set to deliver less than 10 PSIG.

Increase process regulator to deliver more than 10 PSIG.

## **PT-3 (Purge Cylinder Transducer) Alarms**

The following is a possible purge cylinder transducer alarm.

### **4.6.14 Low Purge Cylinder Pressure or Very Low Purge Cylinder Pressure**

**Probable Cause**

**Corrective Action**

Purge cylinder pressure is below user setpoint.

Change purge cylinder following purge gas cylinder procedures in Section 3.3.1 of this manual.



## PT-4 (Purge Delivery Transducer) Alarms

The following are possible purge delivery transducer alarms.

### 4.6.15 Low Purge Delivery Pressure

Probable Cause	Corrective Action
Purge delivery pressure is below user setpoint.	Adjust purge gas pressure regulator to the desired pressure. Change purge cylinder as required following procedures in Section 3.3.1 in this manual.

### 4.6.16 High Purge Delivery Pressure

Probable Cause	Corrective Action
Purge gas delivery pressure is too high.	Adjust purge pressure regulator to the desired pressure. Observe regulator for proper operation. Advise supervisor or contact APCI if regulator will not maintain setpoint.

## PT-5 (Vent Line Transducer) Alarms

The following are possible vent line transducer alarms.

### 4.6.17 High Vent Pressure

Probable Cause	Corrective Action
Vent line pressure is above user setpoint.	Check pollution abatement equipment for obstruction.

### **4.6.18 Low Vacuum Generated PT-5**

**Probable Cause**

**Corrective Action**

Vacuum Venturi supply pressure or flow requirement is insufficient.

Verify a Venturi supply of 75-95 PSIG at 50-60 SLPM is obtainable.

## **PT-8 (Purge Header Transducer) Alarms**

The following are possible purge header transducer alarms. This transducer is located downstream of the purge panel and purge purifier (if installed).

### **4.6.19 High Purge Delivery PT-8 or Very High Purge Delivery PT-8**

**Probable Cause**

**Corrective Action**

V-4 (Purge Gas Inlet Valve) and check valve failure resulting in process gas entering the common purge header.

Verify alarm was not caused by high purge gas delivery pressure. If not, assume V-4 is leaking and purge panel, purge purifier and purge cylinder are contaminated with process gas. Take appropriate action. Contact an Air Products Representative for assistance.

## **Scale Alarms**

The following is a possible scale alarm.

### **4.6.20 Low Cylinder Weight or Very Low Cylinder Weight**

**Probable Cause**

**Corrective Action**

Process cylinder weight is below setpoint.

Change cylinder following procedure found in process cylinder change procedures in Section 3.3.2 of this manual.

## **Section 5: Maintenance**

---

### **5.1 Warranty**

Seller warrants the Equipment manufactured by it to be free from defects in material and workmanship at the time of shipment from Seller's factory for a period of twelve (12) months from the date of shipment, (herein referred to as the "warranty period"). If, during the warranty period, any part of such Equipment is found to have been defective or damaged at the time it was shipped, at Seller's option it will either be repaired at Seller's factory, or it will be replaced by a similar part provided that Buyer gives Seller immediate written notice upon the discovery of any defective or damaged items, whereupon Seller shall have the option of requiring the return of the defective material to establish the claim. This warranty is expressly conditioned upon installation of the Equipment in accordance with the Equipment drawings and instructions of the Seller, and upon Buyer availing itself of the services of Seller's installation and startup advisors, to ensure the correct installation and successful operation of the equipment.

As to all apparatus and products not manufactured by Seller which are component parts of the Equipment, furnished by Seller, Seller's only obligation shall be to obtain for Buyer such warranties or guarantees are obtainable from the manufacturer's. Such warranties or guarantees shall extend over the longest period of time obtainable in this instance without payment by Seller of additional consideration therefor, and Seller shall use reasonable efforts to require its vendors to fulfill obligations of their warranties or guarantees on such apparatus or products furnished in connection with this quotation or any contract resulting therefore.

The replacement or repair of defective parts, as aforesaid, shall be Buyer's only remedy for breach of the material and workmanship warranties of Seller. As to the Equipment of other manufacturers, resort shall be had against such manufacturers only. No allowance will be made for repairs or alterations made without the written consent of Seller, in which event all Seller's warranties hereunder shall be

void and of no effect. Buyer agrees to assume responsibility and pay for such defects which are attributable to it and for damages which may occur to the Equipment after delivery to it. Seller shall not be responsible for any defects due to or caused by normal wear and tear, corrosion, erosion or disregard of Seller's operating and maintenance instructions, or improper use of equipment.

## **5.2 Routine Maintenance**

The following maintenance needs to be done at the indicated times.



*Maintenance is only to be performed by trained personnel who understand the hazards of the system.*



*Personal injury or death may result if proper personal protective equipment (PPE) is not worn when performing troubleshooting. See Section 1.2 of this manual for the proper PPE.*



*Before attempting to service the system components, all pressure in the system should be relieved. Close the cylinder valve(s) and then vent all pressure in the system. Purge out all process gas lines and seal them. The process gas cylinder must be removed from the gas cabinet following the process cylinder procedures in Section 3.3.2 of this manual. Tag out and lock out the cylinder valve(s) (see Section 1.4 of this manual) to prevent opening while service is being performed. Once the maintenance is complete, helium leak test the system using a mass spectrometer. Follow the start-up procedure, in Section 3.4 of this manual.*



*Turn off electrical power to the system before performing controller maintenance.*

<b>Item</b>	<b>Task</b>	<b>Frequency</b>
System	Visually inspect for damage, leaks, or malfunctioning components.	Daily
	Check process and purge pressures for readings that are outside of the specification range (found in Section 6 of this manual) or dramatic changes from previous values.	Daily
	Observe the interior of gas cabinet for any signs of corrosion or gas leakage.	Daily
Pressure gauges and transducers	Check pressure gauge readings against cylinder change check list pressure readings. If process gas pressure must be adjusted, observe delivery transducer or gauge for smooth pressure increase or decrease.	Daily
All valves and regulators	Examine each valve and regulator for external leaks. Replace as required.	Every six months

<b>Item</b>	<b>Task</b>	<b>Frequency</b>
1/4 turn diaphragm valves	Observe 1/4 turn diaphragm valves in closed position. If the needle is not in the green zone, follow manufacturer's adjustment or repair procedure.	Every six months for corrosive gases. Yearly for noncorrosive gases.
Filters	Remove filter from line (if applicable). Install VCR plug or cap over open fittings. Examine filter for signs of plugging and replace filter or filter cartridge if necessary. It may desirable to measure flow through the filter with an inert gas to assure that it is not plugged. Test particle performance.	Every six months for corrosive gases. Yearly for non-corrosive gases.
Check valves <i>(Install VCR plug or cap over each open fitting on gas panel to prevent contamination)</i>	Shut down and purge entire system completely. Remove all check valves. Test check valves to manufacturer's specified leak rate. Repair or replace any defective check valves.	Every six months for corrosive gases. Yearly for non-corrosive gases.

<b>Item</b>	<b>Task</b>	<b>Frequency</b>
Safety relief valves <i>(Install VCR plug or cap over each open fitting on gas panel to prevent contamination)</i>	Shut down and purge entire system completely. Remove all safety relief valves. Test safety relief valves to assure they relieve at manufacturer's specified pressure setting. Repair or replace any defective safety relief valves.	Every six months for corrosive gases. Yearly for non-corrosive gases.
Pigtail cylinder connection	Examine pigtail nipple orifice (if installed) for evidence of plugging or corrosion. Replace if there is evidence of damage. <b><i>Do not operate system without restrictive flow orifice in cylinder valve or CGA nipple, if required.</i></b>	Every cylinder change or every six months (whichever occurs first)
Pressure regulators	Observe operation of regulators during pressure adjustment. If pressure changes are not smooth, remove regulator and replace it.	Every cylinder change
Cylinder connection	Examine cylinder connection for damage.	Every cylinder change
Cabinet exhaust screen (if installed)	Check for clogging. Replace or clean as required.	Every cylinder change
Transducers	Check calibration of all transducers.	Yearly

<b>Item</b>	<b>Task</b>	<b>Frequency</b>
Purifiers	Remove and replace process and/or purge gas purifiers.	As required



*All components and parts have been selected by Air Products to be compatible with the gas or gases to which they may be exposed. This is particularly critical for the softgoods (i.e. o-rings, valves, seats and seals, etc.) It is critical that replacement components and parts be identical to the original item to avoid hazardous malfunctions or leaks. Consult Air Products if there is any question about the part to be used and its compatibility with a particular gas.*

### **5.3 Safety Interlock Maintenance**

The following maintenance should be performed to verify functioning of the process alarm safety interlocks. Setpoints for the safety interlocks are located in Section 6, System Specific Information of this manual.

<b>Item</b>	<b>Task</b>	<b>Frequency</b>
EFS-1, Excess flow	Verify that process flow rate above the setpoint shuts the system down.	Every six months
PT-2, Very high process delivery pressure	Verify that process delivery pressure above the setpoint shuts the system down.	Every six months



## **Section 6: System Specific Information**

---

This section contains the information specific to the system. Included in this section are the system specifications, drawings, recommended spare parts and program logic chart.



## **6.1 System Specifications**

The specifications for the system follow this page.



## **6.2 System Drawings**

The drawings for the system follow this page.



## **6.3 Recommended Spare Parts**

The recommended spare parts for this system follow this page.





## **6.4 Program Logic Chart**

The program logic chart for the system follows this page.

